



ANDERSON-NEGELE

Anderson Instrument Co., Inc.
156 Auriesville Rd. ~ Fultonville, NY 12072
Phone: 518-922-5315 or 800-833-0081

Literature and Specifications available at:
www.anderson-negele.com

Key Product

- ▶AJ Series Chart Recorder
- ▶CT/SA Temperature Sensors

Industry

Dairy

Application

- ▶Specialized controls for VAT Pasteurization
- ▶System over view
- ▶Wiring diagram

This document contains a system over view drawing, as well as detailed wiring information.

Material is designed to supplement the AJ 300 Series Chart Recorder Installation, Wiring and Operations manual. Be sure to follow proper guidelines for mounting, as well as the connection to an AC power source.

Technical Bulletin

VAT Pasteurization - Electronic Controls Package

Wiring Diagrams

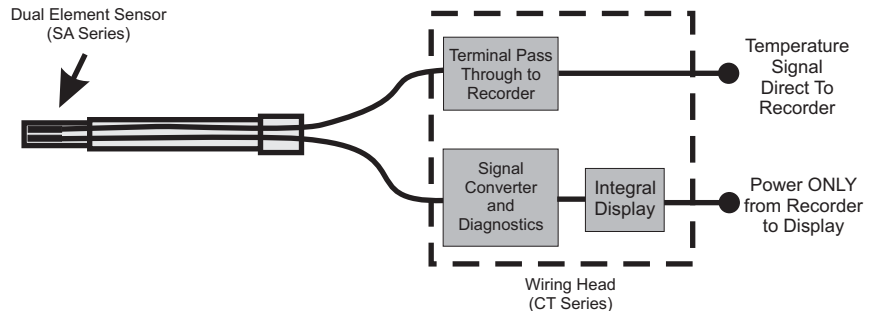
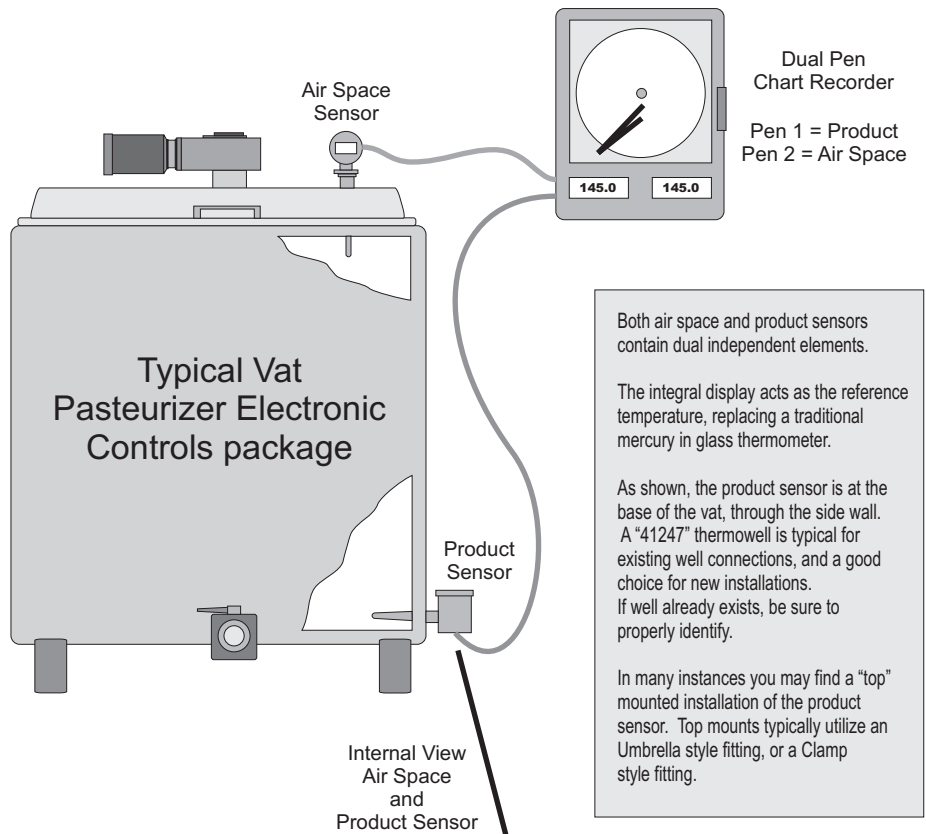

NOTE

As shown, this system addresses all requirements of the Pasteurized Milk Ordinance (PMO) section covering "Combination Electronic Thermometers for Batch Pasteurizers." This "concept" was approved at the 2005 National Conference on Interstate Milk Shipments (NCIMS). The upcoming re-write of the Pasteurized Milk Ordinance will include these new details.

For any additional Regulatory issues pertaining to the use of these components as described, please contact:

Gary Ratajczak

800-833-0081 x577

PRODUCT SENSOR

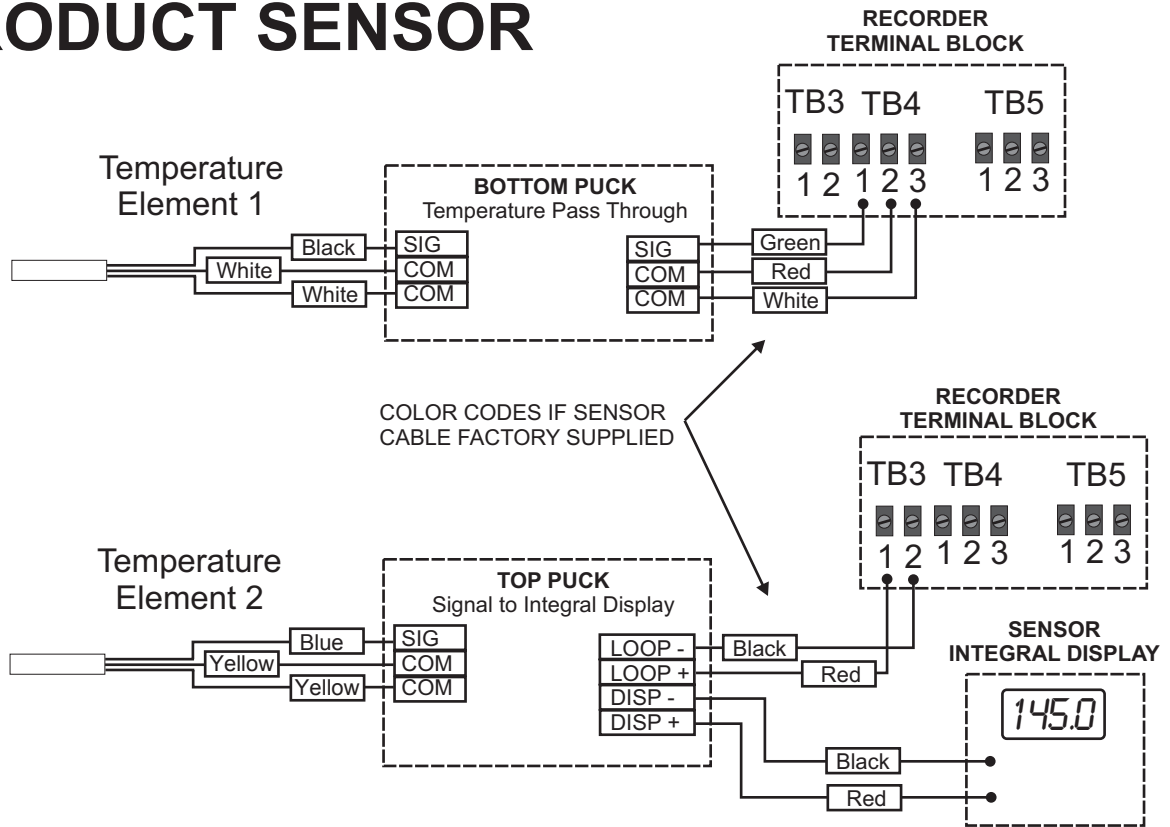

AIR SPACE SENSOR

