

Process adaptors and fittings

PHARMA

Hygienic installation systems for pipes and tanks in pharmaceutical applications

PHARMadapt ESP

Temperature measurement without media contact

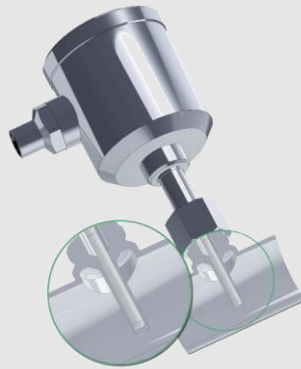

PHARMadapt EPA

Temperature / Point level measurement in narrow measuring points



Fitting system CPM

Pressure measurement with flush installation in smallest pipe diameters

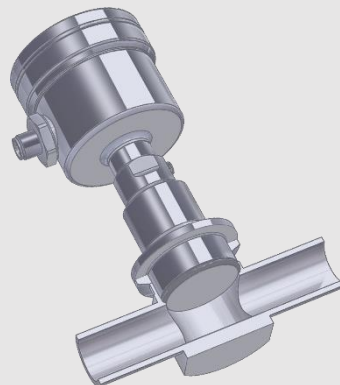

No process stop due to sensor removal during recalibration or replacement Temperature control without media contact

With the ESP installation system, a thermowell is permanently installed in the process. The slim tip of the sensor is inserted into this thermowell and held in contact by a spring. It is therefore **not in direct contact** with the medium.

The sensor can be removed at any time for **recalibration or replacement**, without electrical disconnection and without opening the process, and consequently **without necessity to shut down the plant or to stop the process**.

- **Tailored to requirements:** Special design for pharmaceutical applications
- **Variable:** Installation in tanks using welding sockets or adapters. Installation in pipes using tees or elbows with integrated thermowells
- **Fast and precise:** t50 response time from 4.4 seconds, measuring accuracy $< \pm 0,25 \text{ }^\circ\text{C}$
- **One for all:** One sensor type with the same probe length can be used for differing pipe widths, thus **minimizing spare parts inventory** and planning requirements
- **Reliable:** Spring-mounted tip for perfect contact
- **Maximum hygiene:** No product contact = **No risk of contamination** by previous products, foreign bodies and germs via the sensor
- Easy to clean: **design without dead-legs** ensures easy CIP/SIP cleaning
- **Certified quality:** PHARMadapt ESP complies with current norms, specifications and standards such as 3-A, FDA, USP... (see product information)

Available temperature sensors

- **TSBP / TSMP**
- **Accuracy class:** A | AA (1/3B) | AAA (1/10B)
- **Options:** 2x Pt100 | LCD display | transmitter

Available installation systems for pipes and vessels

- **Weld-in thermowells**
- **Adapters** for diverse process connections (Tri-Clamp, Varivent...)
- **Extension sleeves** for insulated / double-walled vessels
- **Fittings with pipe sections** (designed for orbital welding, to reduce time and quality problems compared to sleeve welding):
 - Tees DN8...DN100
 - Elbows DN10...25 | DN ½" ...1"



The perfect installation situation
for every application, in all pipes
and vessels

TSBP / TSMP Temperature sensors (Details see respective product information)

	Type	Head Ø	Pt100	Transmitter available	Electrical connection	Probe length in mm
	TSBP	57 mm	Pt100 Pt1000	✓	M12 Plug PG Cable gland	37 59 83 97 / 160
	TSBP (Display)	63 mm	Pt100 Pt1000	✓	M12 Plug PG Cable gland	37 59 83 97 / 160
	TSMP	18,5 mm	Pt100 Pt1000	✓	M12 Plug	37 59 83 97 / 160

ESP Fitting system (Details see respective product information)

Material: 1.4435 (316L) with 3.1 certificate, surface Ra ≤ 0,8 µm / 0,6 µm / 0,4 µm

	Type	Application	For probe length	Installation length
	ESP-E	Weld-in thermowell for pipes and tanks	83 mm 160 mm	
	ESP-C	Adapter with integrated thermowell for Tri-Clamp 1" ... 1 ½"	83 mm	66 mm
	ESP-B	Adapter with integrated thermowell for BioControl DN25, DN50 and DN65	59 mm	22 mm
	ESP-V	Adapter with integrated thermowell for Varivent DN25 and DN40	37 mm 59 mm	20 mm 42 mm
	ESP-F	Adapter F52 / F46 with integrated thermowell for Fermenter	83 mm	19 mm
	ESP-G	Tee pipe element with integrated thermowell DIN 2: DN10...DN100 ISO: DN8...DN80 ASME: ½" ... 4"	37 mm With ESP-VL: 83 mm 160 mm	Pipe 70...310 mm
	ESP-W	Elbow pipe element with integrated thermowell DIN 2: DN10...DN25 ISO: DN8...DN20 ASME: ½" ... 1"	37 mm With ESP-VL: 83 mm 160 mm	Pipe 35...55 mm bzw. 62...88 mm
	ESP-VL	Extension 46 or 123 mm, for ESP-G Tees or ESP-W elbows	Extension from 37 mm to 83 mm 160 mm	

Aseptic clamp connection for pipes with from DN10 | ISO8 | 3/4" Hygienic sensors for narrow spaces

Especially in pipes with a **small nominal diameter**, the hygienic installation of a temperature or point level sensor is often difficult to realize.

The PHARMadapt EPA installation system, specially developed for pharmaceutical applications, makes this **integration simple and safe**: the **flow-optimized pipe tees** are simply and reproducibly **welded in** and the sensors are inserted by means of a clamp connection.

- **Installation with zero dead-leg or gap:** The design of the adapter creates a flow-optimised and easily cleanable process connection. Dead spaces as with weld-on sockets are avoided by design.
- **Two connection sizes, many pipe diameters:** connection with di= 8 mm or 18 mm, pipes from DN10 to DN100
- **Easy installation:** The EPA adapter can be welded safely and hygienically using the orbital method. The sensor itself is sealed with an O-ring and fixed with a standard clamp
- **Certified quality:** PHARMadapt EPA complies with current norms, specifications and standards such as 3-A, FDA, USP... (see product information)

Available sensors

- **TSBP / TSMP Temperature sensors** (head 57 / 63 mm or 18 mm), with 1x or 2x Pt100 or Pt1000
- **NCS point level sensors**





Variants of the PHARMadapt EPA fitting system

- **EPA-8** DN: DIN 10...100 | ISO 8...80 | ASME 1/2" ...4"
Material: Stainless steel 1.4435 (316L)
Surface: Ra≤0,8 µm (Ra≤0,6 | 0,4 µm optional)
- **EPA-18** DN: DIN 25... 100 | ISO 20...80 | ASME 1" ...4"
Material: Stainless steel 1.4435 (316L)
Surface: Ra≤0,8 µm (Ra≤0,6 | 0,4 µm optional)
- **Pipe standard:** DIN 11866 | ISO 1127 | ASME BPE





Dead leg free installation for every application, with pipe Tees DN10...100



TSBP / TSMP temperature sensors (Details see respective product information)

	Type	Head Ø in mm	PT100	Transmitter available	Electrical connection	Probe length in mm	Fitting system
	TSBP-E08	57	Pt100 Pt1000	✓	M12 Plug PG Cable gland	10 25 50 100	EPA-8
	TSBP-E08 (Display)	63	Pt100 Pt1000	✓	M12 Plug PG Cable gland	10 25 50 100	EPA-8
	TSMP-E08	18	Pt100 Pt1000	✓	M12 Plug	10 25 50 100	EPA-8
	TSBP-E18	57	Pt100 Pt1000	✓	M12 Plug PG Cable gland	20 50	EPA-18
	TSBP-E18 (Display)	63	Pt100 Pt1000	✓	M12 Plug PG Cable gland	20 50	EPA-18
	TSMP-E18	18	Pt100 Pt1000	✓	M12 Plug	20 50	EPA-18

NCS Point level sensors (Details see respective product information)

	Type	Head Ø in mm	Measuring range	Fitting system
	NCS-61P	50	Dk ≥ 20	EPA-8
	NCS-62P	18	Dk ≥ 5	EPA-8
	NCS-81P	50	Dk ≥ 20	EPA-18 EPA-18G
	NCS-82P	18	Dk ≥ 2	EPA-18 EPA-18G

PHARMadapt EPA Fitting systems (Details see product information)

	Typ	Pipe standard	Pipe widths DN
	EPA -8 / A	Series A (DIN 11866)	DIN 10 15 25 32 40 50 65 80 100
	EPA -8 / B	Series B (ISO 1127)	ISO 8 10 15 20 25 32 40 50 65 80
	EPA -8 / C	Series C (ASME BPE)	ASME ½" ¾" 1" 1½" 2" 2½" 3" 4"
	EPA -18 / A	Series A (DIN 11866)	DIN 25 32 40 50 65 80 100
	EPA -18 / B	Series B (ISO 1127)	ISO 20 25 32 40 50 65 80
	EPA -18 / C	Series C (ASME BPE)	ASME 1" 1½" 2" 2½" 3" 4"

Optimized pressure measurement for smallest pipe diameters Zero dead-leg, completely flush installation

For high-precision and hygienic pressure measurement, the pressure diaphragm must be integrated into the process as flush as possible and without dead space. This is a particular challenge for pipes with small nominal diameters.

Here, the CPM installation system offers a process connection that is easy and safe to install and offers unique advantages due to its special design.

- **Zero dead-leg installation with perfect diaphragm position:** Due to the design of the CPM adapter and the extension of the sensor nozzle, the pressure diaphragm sits inline precisely at the height of the media feed-through. This results in an absolutely flow-optimized and hygienic process adaptation. Due to the design of the CPM, dead spaces such as with Tees or weld-on sockets are excluded.
- **Pressure sensors with standard sizes:** Pressure sensors with standard diaphragm diameters of 22 or 38 mm are also used for the smallest nominal pipe diameters from ¼". Measurement tolerances such as those for smaller diaphragm diameters are avoided by design
- **Easy installation:** The CPM adapter is simply fixed in the process with Tri-Clamp or can be welded safely and hygienically with AWF welding collar in orbital process. The pressure sensor itself is sealed with an O-ring and mounted with a standard 1½" clamp

Available pressure transmitters and gauges

- L3 Pressure and level sensor
- MPP Modular pressure and level sensor
- PF Modular pressure sensor
- HA Pressure sensor (autoclavable)
- EK Pressure gauge 63 mm (autoclavable with CPM)
- EM Pressure gauge 90 mm (autoclavable)
- EP Pressure gauge with digital display

Variants of the CPM fitting system

- CPM (Ø 38,1 mm), for nominal widths ½" - 4"
- CPM Mini (Ø 22,2 mm), for nominal widths ¼" - ½"
- Tri-Clamp connection, for nominal widths ½" - 4"
- AWF (butt weld), for nominal widths ¼" - 4"
- Material: Stainless steel 316L (Option: Hastelloy)
- Surface: Ra = 0,4 | 0,5 | 0,6 µm (see table)





Zero dead-leg, flush front
inline process connection for
pipes from ¼" to 4"

Fitting system CPM Pressure

CPM Fitting systems (Details see product information)





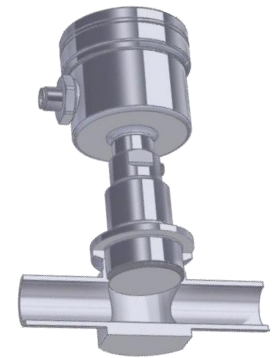

Materials:

Stainless steel 316L with 3.1 Certificate with batch number | (Hastelloy (Option)
O-Ring EPDM USP Class VI (Standard) | Silicon or Viton (Option)

	Type	Pipe size	Connection	Surface Ra Ep= electropolished	Length in mm
	CPM Mini	¼"	AWF (butt weld)	Ra≤0,5 (ep)	101,6
	CPM Mini	½"	AWF (butt weld)	Ra≤0,4 (ep)	101,6
	CPM Mini	½"	Tri-Clamp	Ra≤0,4 (ep)	152,4
	CPM	½"	AWF (butt weld)	Ra≤0,4 (ep)	133,4
	CPM	½"	Tri-Clamp	Ra≤0,4 (ep)	114,3
	CPM	¾"	AWF (butt weld)	Ra≤0,4 (ep)	133,4
	CPM	¾"	Tri-Clamp	Ra≤0,4 (ep)	120,7
	CPM	1"	AWF (butt weld)	Ra≤0,4 (ep)	120,7
	CPM	1"	Tri-Clamp	Ra≤0,4 (ep)	133,4
	CPM	1-½"	AWF (butt weld)	Ra≤0,4 (ep)	139,7
	CPM	1-½"	Tri-Clamp	Ra≤0,4 (ep)	146,1
	CPM	2"	AWF (butt weld)	Ra≤0,4 (ep)	177,8
	CPM	2"	Tri-Clamp	Ra≤0,4 (ep)	171,5
	CPM	2-½"	AWF (butt weld)	Ra≤0,6	184,2
	CPM	2-½"	Tri-Clamp	Ra≤0,6	184,2
	CPM	3"	AWF (butt weld)	Ra≤0,6	196,9
	CPM	3"	Tri-Clamp	Ra≤0,6	196,9
	CPM	4"	AWF (butt weld)	Ra≤0,6	241,3
	CPM	4"	Tri-Clamp	Ra≤0,6	241,3



Available pressure transmitters and gauges (Details see respective product information)

	Type	Application	Connection		Type	Application	Connection
	L3	Pressure and level sensor	CPM		HA	Pressure sensor (autoclavable only with CPM)	CPM CPM Mini
	MPP	Modular pressure and level sensor	CPM CPM Mini		EK	Pressure gauge 63 mm (autoclavable only with CPM)	CPM CPM Mini
	PF	Modular pressure sensor	CPM		EM	Pressure gauge 90 mm (autoclavable)	CPM
					EP	Pressure gauge with digital display	CPM CPM Mini

Illustrations partly not with CPM connection



HYGIENIC BY DESIGN

ANDERSON-NEGELE

Process adaptors and fittings

PHARMA



North America

Anderson Instrument Company Inc.
Fultonville, NY 12072
USA

Tel. +1 518-922-5315
Fax +1 518-922-8997
info@anderson-negele.com

Europe / EMEA

Negele Messtechnik GmbH
Raiffeisenweg 7, 87743 Egg an der Guenz
GERMANY

Tel. +49 8333-9204-0
Fax +49 8333-9204-49
sales@anderson-negele.com

India

Anderson-Negele India
Kurla (West), Mumbai – 400 070
INDIA

info.india@anderson-negele.com

China

Anderson-Negele China
518 Fuquan North Road, Shanghai,
200335
P.R. CHINA

Tel. +86 400 666 1802-7
china.sales@anderson-negele.com

Latin America

SPTech
Tamboré - Barueri - São Paulo
BRASIL

Tel. +55 11 3616-0150
atendimento@sptech.com