

Product Information MAN-63 **FOOD**

Pressure Gauge MAN-63



Application

- Hygienic pressure measurement

Application examples

- Local display without power supply

Hygienic design/Process connection

- By using the Negele weld-in sleeve **EMZ-352**, a hygienic and easy cleanable measurement point will be achieved
- Adapter for DIN 11851, Varivent, SMS, RJT etc.
- Direct connection for 3/4" und 1" Tri-Clamp
- CIP-/ SIP-cleaning up to 149 °C (300 °F) / maximum 60 minutes
- Gauges completely made of stainless steel
- Sensor materials and actuating fill are FDA conform
- IP 66, housing for optimized cleanability
- Conforming to 3-A Sanitary Standard 74-06 for sensors with Tri-Clamp process connection
- EHEDG certified hygienic process connection with **CLEANadapt** fitting

Features

- Complete device is certified by 3-A-SSI
- With **CLEANadapt** an easy adaption to all process connection is possible
- Zero adjustable
- Surface $R_a \leq 0.6 \mu\text{m}$ (0.6 microns, 24 micro-inches) is standard

Options

- Case filling with glycerine for damping
- Actuating fill with Neobee M20

Authorizations



MAN-63 / TC3/4



MAN-63 / S



Hygienic elastomer free sealing principle for MAN-63 / S

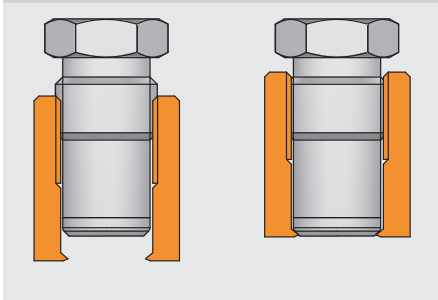

Specification		
Material	diaphragm	1.4404 (316L) $R_a \leq 0.6 \mu\text{m}$ (0.6 microns, 24 micro-inches)
	fitting	1.4404 (316L)
	bourdon tube	1.4301 (304)
	movement	1.4301 (304)
	case	1.4301 (304)
	inspection window case fill	polycarbonat glycerine (option)
Actuating fill	FDA approval number	paraffin oil / medical white oil 21 CFR 172.878 and 21 CFR 178.3620(a)
	option	Neobee M20
Protection class		IP 66
Over-range capability		minimum 25 % over range
Accuracy		± 1.5 % of full scale
Repeatability		± 0.5 % of full scale
Linearity		± 0.5 % of full scale
Hysteresis		± 0.5 % of full scale
Temperature	process	-3 °C...140 °C (25 °F...284 °F)
	CIP / SIP	149 °C (300 °F) / maximum 60 minutes
	ambient	4 °C...49 °C (40 °F...120 °F)
		slower reaction at deep temperatures
Stability	from 10...90 % of range	$< \pm 0.01$ % / K of full scale in process or ambient temperature
Weight		140....390 g (depending on process connection and filling)

Overview of deliverable process connections for MAN-63 / S (adapters must be ordered seperately!)
The complete overview of all available adapters you will find at product information **CLEANadapt**.

MAN-63 / S						
Process connection		Build-in system EHG (DIN 11850 series 2)	Negele weld-in sleeve	Tri-Clamp	Diary flange (DIN 11851)	DRD (press ring optional deliverable)
DN25	1"	-	EMZ-352	AMC-352/DN25	AMK-352/DN25	-
DN40	1½"	EHG-DIN2-40/1"	suitable for installation in vessels	AMC-352/DN25	AMK-352/DN40	-
DN50	2"	EHG-DIN2-50/1"		AMC-352/DN50	AMK-352/DN50	AMK-352/DN50
DN65	3"	EHG-DIN2-65/1"	EMS-352	AMC-352/ DN65	AMK-352/DN65	AMK-352/DN50
DN80		EHG-DIN2-80/1"	suitable for installation in pipes	AMC-352/DN80	AMK-352/DN80	AMK-352/DN50
DN100		EHG-DIN2-100/1"		AMC-352/DN100	AMK-352/DN100	AMK-352/DN50

MAN-63 / TC3/4

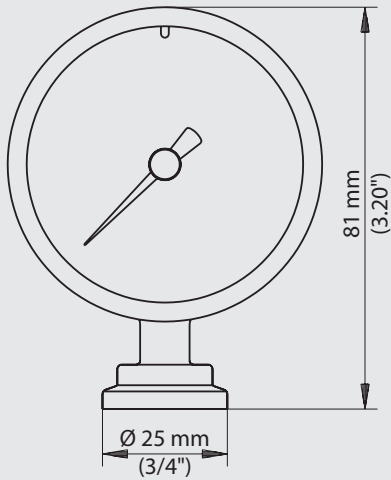

MAN-63 / TC3/4

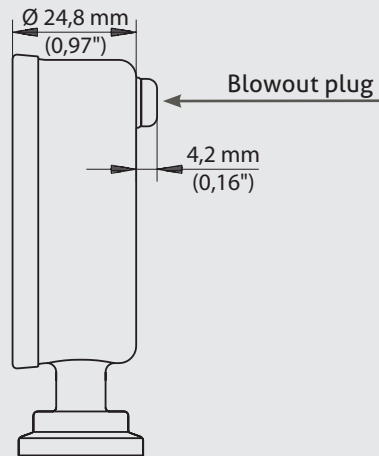

MAN-63 / TC1

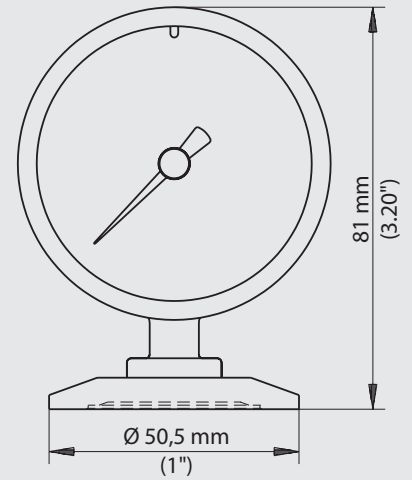

MAN-63 / TC3/4 connection L (left) / R (right)

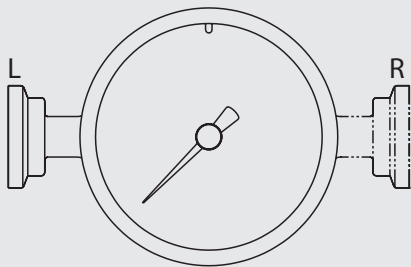

MAN-63 / S connection L (left) / R (right)

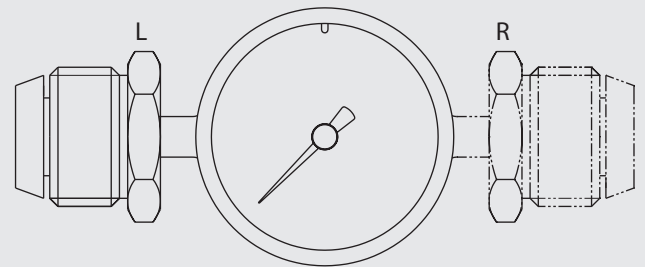

MAN-63 / S

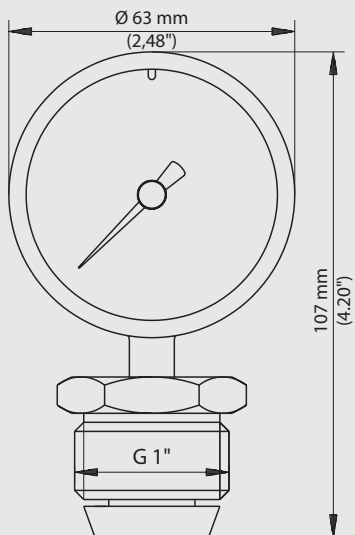

MAN-63 / S

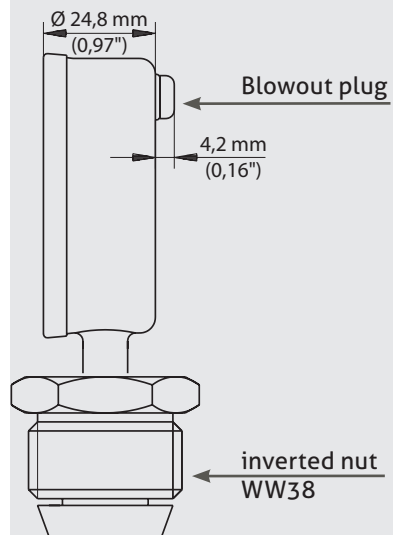

Order code

MAN-63	(diameter housing 63 mm)					
	Process connection					
	TC3/4	(Tri-Clamp 3/4")				
	TC1	(Tri-Clamp 1")				
	S	(CLEANadapt G1"; not with 3-A TPV Verification)				
		Measuring range				
		-1...+2	(-1.0...2.0 bar)			
		-1...+4	(-1.0...4.0 bar)			
		0...2	(0...2.0 bar)			
		0...4	(0...4.0 bar)			
		0...6	(0...6.0 bar)			
		0...7	(0...7.0 bar)			
		0...11	(0...11.0 bar)			
			Filling			
		X	(paraffin oil)			
		GC	(Neobee M20)			
			Calibration possibility			
		X	(without)			
			Damping			
		X	(without)			
		GZ	(glycerine filling)			
			Connection			
		U	(down)			
		L	(left)			
		R	(right)			
MAN-63 /	TC1 /	0...2 /	X /	X /	X /	U

Conditions for a measuring point according to 3-A Sanitary Standard 74-06



- The sensors MAN-63 / TC... conforming to the 3-A Sanitary Standard.
- The sensors are designed for CIP-/ SIP-cleaning. Maximum 149 °C / 60 minutes.
- Only with 3-A conforming Tri-Clamp process connection.
- Mounting position, self draining and the position of the leakage hole must be in accordance to current 3-A Sanitary Standard.