

30022 / 1.6 / 2025-04-29 / RF / EN_EU

Installation and operating instructions

Relative Turbidity Meter

ITM-51 / ITM-51R



Note

The contents of this document are the intellectual property of Anderson-Negele. Any reproduction or translation without written permission is prohibited.

Please read these installation and operating instructions carefully. All instructions in this manual must be followed exactly to ensure proper operation of the unit.

If you have any questions regarding the product, installation or commissioning, please contact Anderson-Negele Support at support under:

America:
Phone 800-833-0081
techservice@anderson-negele.com

Other countries:
Phone +49-8333-9204720
support@anderson-negele.com

Table of contents

1	Application / intended use	3
2	Conformity with standards.....	3
3	Safety instructions	3
4	Special features / advantages.....	4
5	Options / Accessoires	4
6	Installation and Connection	4
6.1	Mounting position.....	4
6.2	Hygienic installation requirements.....	5
6.3	Configuration	6
6.4	Settings using the MPI-200 programming adapter	7
6.5	Settings using the User Interface.....	11
6.5.1	Screen display.....	12
6.5.2	LED configuration	13
6.6	Examples of sensor settings.....	13
6.6.1	Menu structure User Interface	14
6.6.2	Example for setting turbidity 1 range without an ID code:	15
6.6.3	Setting of customer-specific turbidity / %solids curve via PC software...	16
7	Installation of the "Large User Interface" (LUI).....	17
7.1	Retrofitting the display if a display was not yet installed	17
7.2	Retrofitting the display if a small display (SUI) was already installed	18
8	Dimensions	19
9	Electrical Connection Analog Signal Modules	21
10	Electrical Connection Digital Signal Modules	21
11	ITM-51 IO-Link Device Identity	24
12	ITM-51 IO-Link Process Data.....	24
12.1	ITM-51 IO-Link Process data description	25
12.2	IO-Link Eventlist	26
13	Repair and maintenance.....	28
14	Technical data.....	29

1 Application / intended use

- Relative turbidity measurement of liquid media for mid to high turbidity range (200...300.000 NTU equivalent)
- For use in hygienic applications of the food, beverage and pharmaceutical industries
- Suitable for CIP/ SIP up to 140 °C for a maximum of 120 minutes
- Not suitable for use in explosive atmospheres
- Not suitable for safety-related unit parts (SIL)

2 Conformity with standards

The basic safety and health requirements are met through fulfillment of:

- 2014/30/EU Electromagnetic Compatibility
- 1935/2004/EU Consumer Goods Ordinance
- EN 61000-6-2:2005 (Interference Immunity)
- EN 61000-6-4:2007 + A1:2011 (Interference Emissions)

3 Safety instructions

These safety instructions must be followed to

- Avoid endangering persons and the environment.
- Avoid damage to the sensors.
- Prevent faulty batches during production.

The electrical connections may only be performed by persons with the necessary technical skills (e.g. certified electricians or persons with technical training in electrics) and by persons with the necessary authorization from the operator.

The power supply and the control circuit inputs and outputs must be professionally wired. The current state-of-the-art of electrical connections must be adhered to. See also **section 8** "Wiring diagram".

The following details must be noted in particular:

- Safety instructions
 - Electrical connection data
1. All persons involved with the setup, commissioning, operation, service and maintenance of the sensor must be suitably qualified.
 2. This operating manual must be followed closely. The operator must ensure that the personnel has read and fully understood the operating manual.
 3. All work must be performed with utmost care and may only be executed by authorized and trained personnel. The applicable national regulations regarding opening and repairing of devices must be complied with.
 4. We recommend storing the operating manual near the measuring device in an easily accessible location.
 5. The sensor must be de-energized prior to alterations and maintenance.
 6. The working area of the operator must offer enough space to minimize the risk of injury.
 7. The technical data specified in the operating manual and on the type plate must be noted.

Warranty coverage shall not be granted for any damage that can be attributed to improper execution of work on the device.

4 Special features / advantages

- The sensor structure is based on a modular device platform which can be tailored to requirements and is easy to exchange if faulty
- Front flush sensor for easy cleanability
- Optics made of high resistance sapphire
- Independent to reflexions at small diameters or electro-polished surfaces
- Color independent measurement at 860 nm wave length
- Hygienic design with Negele weld-in sleeve
- Individual setting/programming via PC or User Interface
- Two configurable LEDs on the display unit

5 Options / Accessoires

- User Interface with small or large display (retrofitable)
- Programming adapter MPI-200 (PC-based)
- Tool for detaching the signal module
- Full featured remote version (see order matrix for ITM-51R)
- Pre-assembled PVC cables

6 Installation and Connection

6.1 Mounting position

Mechanical connection / installation notes



- The sensor must be installed in that way that the sensor tip is entirely washed around by media and no bubbles can occur. It therefore is advisable to install the device in rising pipes. Refer to the drawings below for reference.

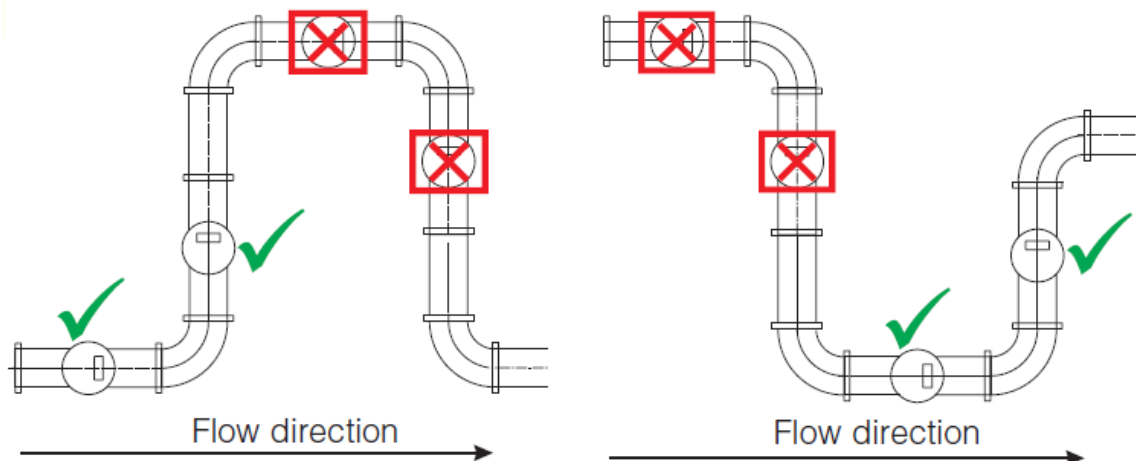

6.2 Hygienic installation requirements

Conditions for hygienic installation according 3A and EHEDG



- The ITM-51 / ITM-51R is designed for CIP/SIP cleaning. The sensor can withstand a maximum of 140 °C / 120 min.
- The mounting position must guarantee self-draining properties.
- If mounted with a Tri-Clamp connection the mounting tee, mounting position and gasket need to follow the actual 3A or EHEDG standards and guidelines.

Dimensions for hygienic installation with Tri-Clamp

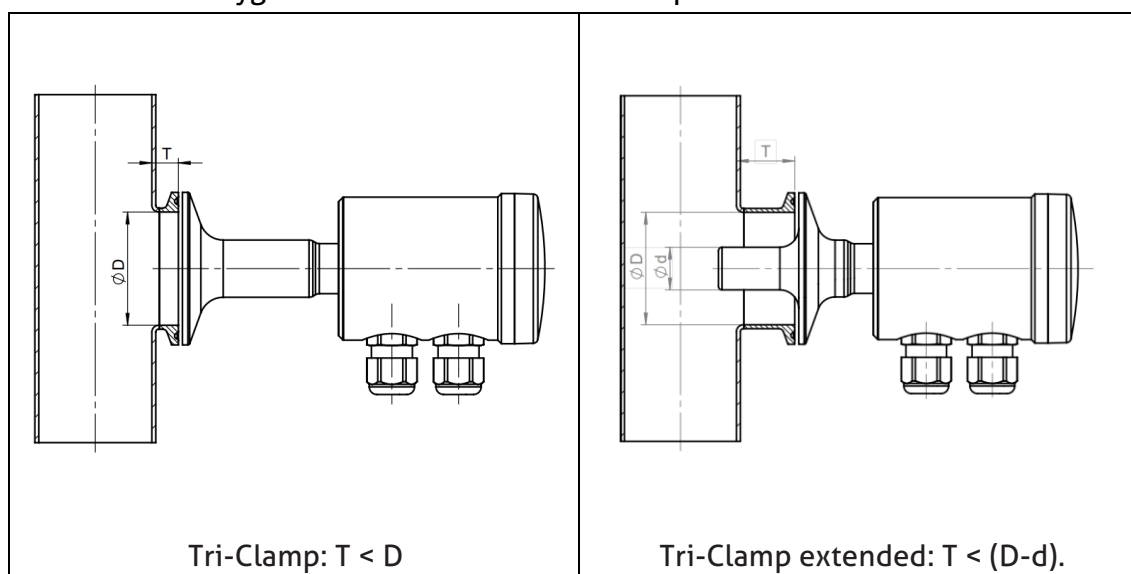

Recommended mounting positions

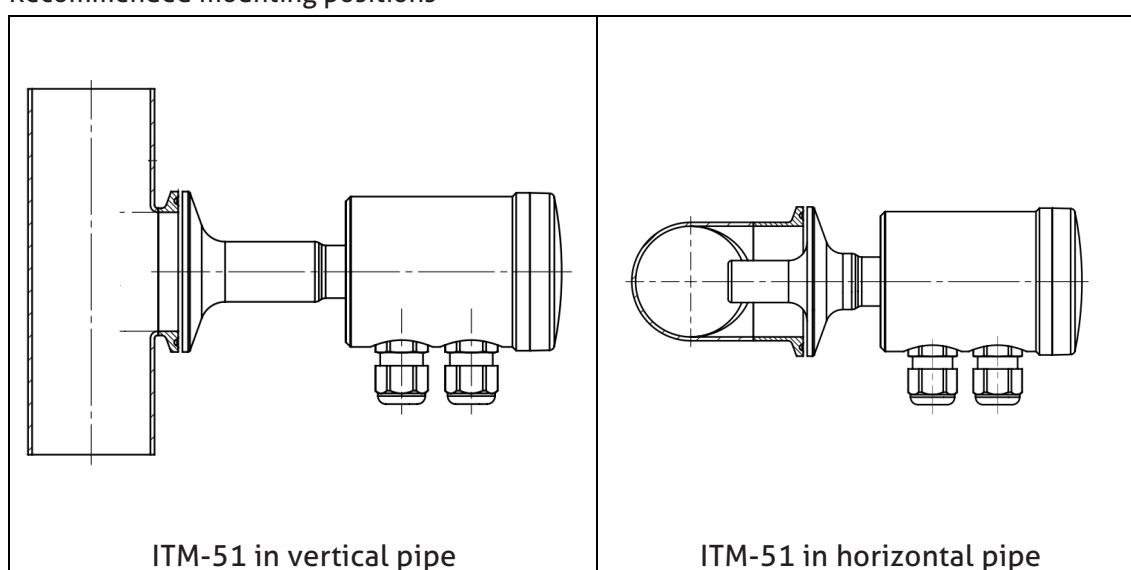

Not permitted mounting positions using Tri-Clamp

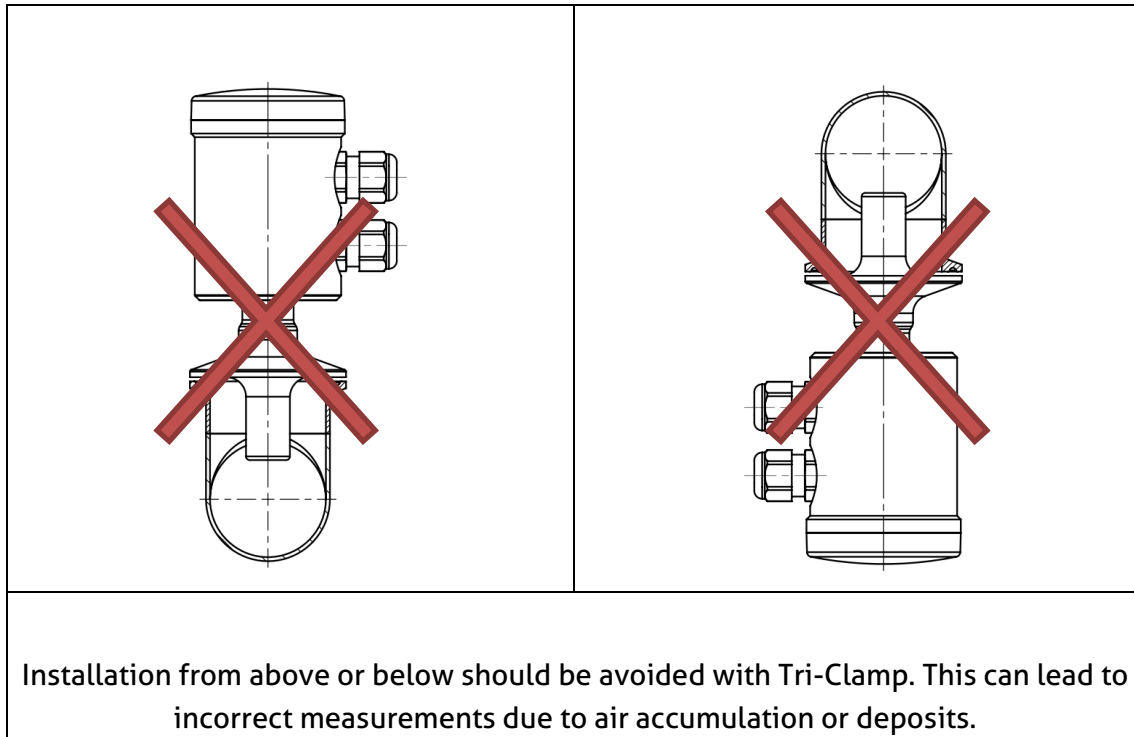

6.3 Configuration

The ITM-51 relative turbidity meter is set to operate without requiring special adaptations. In isolated instances, some parameters may need to be adjusted. The parameterization may be changed using the PC-based MPI-200 programming adapter, IO-Link or the User Interface directly on the sensor. This can be performed either directly on location or in the office in a dry simulation.

The sensor is delivered with the following default settings:

Analog Output 1 (X45 on terminal connection 4 and 5):

turbidity 1 with measurement range 0...100 %TU

Relay Output (X67 on terminal connection 6 and 7): switching output with 10 %TU set point

An external control voltage (24 V DC) can be used to switch between measuring range 1 and 2 at digital input X3. The digital input X3 is short-circuit proof.

The parameter list accompanying the sensor contains the sensor settings for analog output 1 (terminals 4 and 5) under **X45a** and for relay output (terminals 6 and 7) under **X67**.

The ITM-51 relative turbidity meter features a modular design with a "tree structure", which can be tailored to meet requirements and can be easily exchanged in the event of a fault.

This tree structure is used by the MPI-200 programming adapter software for the PC and the User Interface in the sensor. The software is subdivided into **Display, Electronics (signal interface)** and **Sensor (turbidity measurement)**.

When setting the parameters, please note that a hierarchy of authorization levels exists (**0 Monitoring, 1 Adjustment (QuickSetup), 2 Setup 3 Calibration**):

Sensor (turbidity measurement):

The analog output of the sensor for turbidity can be freely configured.

Turbidity: Two different turbidity ranges can be set here, independent of each other. The upper range limit can be freely selected. Switching between the both ranges can be done with the A53/I53 signal module while using the digital switching input X3. This function is not available with the A42/I42 and A52/I52 signal modules.

Switching output (only applicable for A52/I52 and A53/I53 electronics): A setpoint for turbidity as well as the working direction of the switching output can be selected.

Electronics (Signaling interface):

- **Signal selection for the 4...20 mA signal:** Selection between Turbidity 1 or 2 and the applicable turbidity category
- **Set value for 4 or 20 mA signal:** By default, the lower range limit is used for the 4 mA signal and the upper range limit for the 20 mA signal. This can be adjusted as necessary.
- **"No Media" warning signal:** Current loop signal when the sensor is not immersed in a medium → dry running.
- **"Outside Spec." warning signal:** Current loop signal if an operating state is outside of the specified range. The measurement accuracy can no longer be guaranteed.
- **"Global Failure" error signal:** Current loop signal if a malfunction occurs, for example if the device fails.
- **Signal limit for underrange and overrange:** Lower or upper limit of the current loop signal that is still valid and linear when output below 4 mA or above 20 mA.
- **"Underflow/overflow" error signal:** Current loop signal is below or above the underrange or overrange limit.
- **Signaling Simulation:** Simulates the current loop signal, where the source value is briefly replaced by the entered parameter value.
- **LED configuration:** These two LEDs can be configured as required. The procedure is described in section 6.2.2.

A list of the parameters set in the turbidity sensor is included with the delivery. These parameter values, as well as those changed by the users themselves, can be printed out using the MPI-200 programming adapter via **File → Parameter Data → Print** and can also be exported as a file to the PC (via **File → Parameter Data → Export Data File (*.xml)**).

When making the settings, note the help texts in the MPI software for each parameter. They provide useful information on changing the selected parameter.

6.4 Settings using the MPI-200 programming adapter

The MPI-200 programming adapter is connected to the ITM-51 turbidity meter via the external MPI-200-F adapter piece. It must be ensured that the ITM-51 turbidity meter is permanently connected to the supply voltage while the parameters are being set.



Connection plug for the MPI-200-F adapter as an intermediate plug between the ITM-51 electronics and the MPI-200 connection 3 (see the next figure).

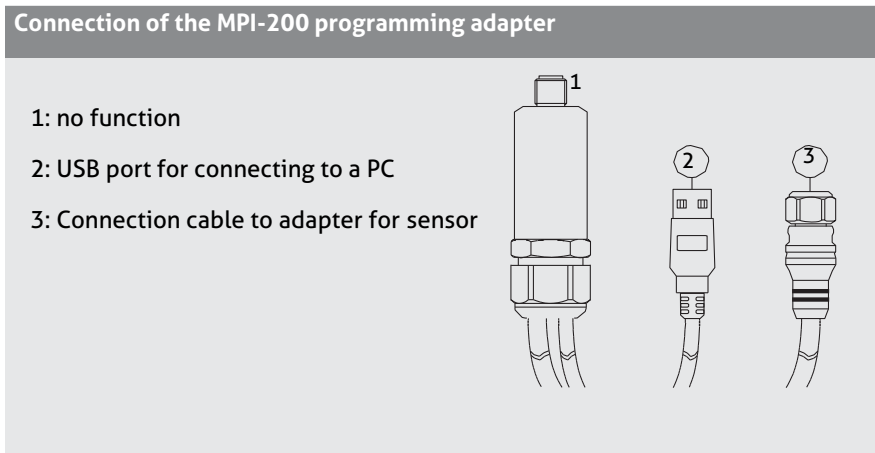

After the sensor is connected to the PC and the user software is opened, the following window appears:

1. Information on the current process value
2. Buttons for changing the parameter setting
3. Information on the current source value
4. Adjustable PC parameters
5. Adjustable sensor parameters

Clicking on the + in the menu opens a submenu in which parameters can be adjusted.

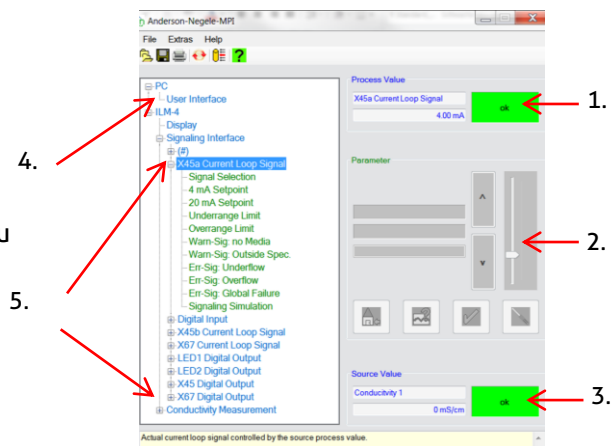

Note:

For further settings, please see also the description in the MPI-200 product information.

To set or change parameters directly in the sensor (see section 6.2 "Settings using the User Interface"), you need the ID codes contained in the table below. This table only lists the most important ID codes.

Further ID codes can be found in the user software. To view these, right-click on "Info" by the parameter name. An info box appears with the respective ID (see graphic below):

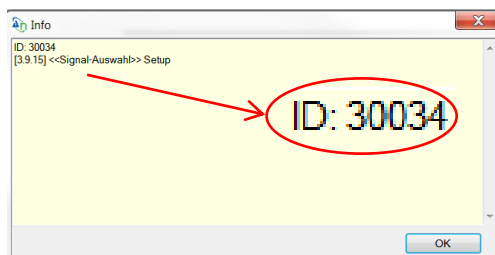

Because the search number must have 6 digits, an additional digit is always added in front of the five-digit ID (30034 in the graphic above). This digit depends on the node as follows:

- 4 for changes to the display
- 3 for changes to the signal interface
- 0 for changes to the turbidity measurement

Because the signal selection is located in the single interface node, the ID code for the "Signal selection" example above is: 330034.

A list of all ID codes can be printed out via the PC user interface. To do so, click on **File → Parameter Data → Print** to open the corresponding window and print out the complete list of ID codes.

List of important ID codes:

Parameter/Parameter Name	Access/Setup Mode	Search Number (ID Number)	Value Name
Sensor			
Unit Turb1	Setup	014021	Turbidity1
Damping 1	Setup	014027	Turbidity1
Range Tb.1	Setup	014029	Turbidity1
Unit Turb2	Setup	014022	Turbidity2
Damping 2	Setup	014028	Turbidity2
Range Tb.2	Setup	014030	Turbidity2
X-Pnt 01	Setup	013151	Tu.%Solids
Y-Pnt 01	Setup	013171	Tu.%Solids

Thru	Setup	Thru	Tu.%Solids
X-Pnt 08	Setup	013158	Tu.%Solids
Y-Pnt 08	Setup	013178	Tu.%Solids
Current Loop Signal 1			
Signal Selection	Setup	330031	X45a I-Out
Underrange Limit	Setup	330141	X45a I-Out
Overrange Limit	Setup	330211	X45a I-Out
no Media=	Setup	330121	X45a I-Out
Out Spec.=	Setup	330221	X45a I-Out
Underflow=	Setup	330151	X45a I-Out
Overflow=	Setup	330161	X45a I-Out
Failure=	Setup	330131	X45a I-Out
Simulation	Setup	330201	X45a I-Out
Digital Input			
Direction	Setup	330821	Digital-In
Simul. Inp	Setup	330831	Digital-In
Current Loop Signal 2			
Signal Selection	Setup	330032	X45b I-Out
Underrange Limit	Setup	330142	X45b I-Out
Overrange Limit	Setup	330212	X45b I-Out
no Media=	Setup	330122	X45b I-Out
Out Spec.=	Setup	330222	X45b I-Out
Underflow=	Setup	330152	X45b I-Out
Overflow=	Setup	330162	X45b I-Out
Failure=	Setup	330132	X45b I-Out
Simulation	Setup	330202	X45b I-Out

Digital Output			
Signal Selection	Setup	330037	X67 D-Out
Function	Setup	331114	X67 D-Out
Direction	Setup	331124	X67 D-Out
Inp. Method	Setup	331114	X67 D-Out
Switch Pt.	Setup	331144	X67 D-Out
Hysteresis	Setup	331254	X67 D-Out
ON Delay	Setup	331174	X67 D-Out
OFF Delay	Setup	331114	X67 D-Out
No Media=	Setup	331194	X67 D-Out
Out Spec.=	Setup	331204	X67 D-Out
Underflow=	Setup	331214	X67 D-Out
Overflow=	Setup	331224	X67 D-Out
Failure=	Setup	331234	X67 D-Out
Simulation	Setup	331244	X67 D-Out
Display			
Language	Setup	451010	Set Display
Contrast	Setup	451020	Set Display
Scrs delay	Setup	451050	Set Display
Password	Setup	450103	Set Display

6.5 Settings using the User Interface

The software structure of the User Interface is similar to PC software version.

The system is operated using two control buttons to the left and right of the display. These two buttons can be used to navigate through the tree structure of the User Interface to change parameters. The button functions are as follows:

Button	Press briefly	Press and hold
R	Jump to next node, parameter	Edit a node, parameter
L	Jump back to previous node, parameter	Leave editing mode without saving, return to next higher level
R/L	Scroll up and down	
R and L together		Press both buttons for 10 seconds: the menu jumps back to the beginning (attention: this is not a reset)

R right

L left

Notes on setting using an ID number

- 1) Press and hold the right button, the display jumps to the menu.
- 2) Confirm right key 2x briefly to position "ID search".
- 3) Press and hold the right key and select the desired item "ID Search"
- 4) Press and hold the right key, then enter the ID number from right to left.

Proceed as follows:

- a) Select the desired position (navigation with right/left - press the left key): Change position to the left, press right key, change position to the right.)
 - b) Press and hold the right-hand key at the desired position until the field is highlighted in grey, then enter the numerical value with the right/left keys and confirm with the right-hand key for a long time until the number is no longer stored. Then enter the next digit.
 - c) When all digits have been entered, press the left or right key until all digits are highlighted in gray.
 - d) Next, press and hold the right key. The system then jumps to the selected parameter and this can now be entered / changed in the same way. Start here - again, press and hold the right button.
 - e) For some system-relevant parameters, a confirmation prompt will appear asking whether the change should be saved or not.
- 5) The input can be aborted by pressing and holding the left button. The setup can be canceled by pressing and holding the left button several times.

- Pressing the right button means that the parameter is changed or saved.
- Pressing the left button means leaving the setting without changing it.

6.5.1 Screen display

After the sensor parameters have been adapted/changed, or after the sensor is switched on and no change is made, the sensor switches to the display mode after a certain period. In the display mode, the main measurement value is shown as described in the picture below. If a second output option is available (only for electronic versions A52, A53) the actual value is shown in the bottom line of the display.

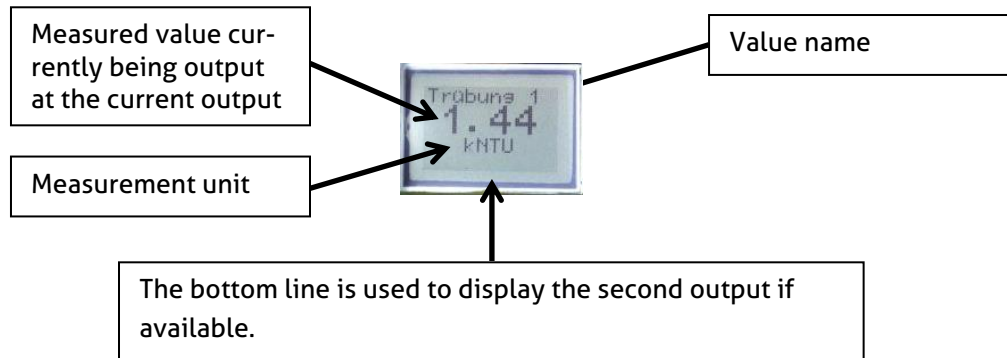

To leave the display mode and create settings on the sensor, press the right button next to the display twice to enter the menu. The sensor then displays the start page, from where the settings can be created.

6.5.2 LED configuration

The display unit features 2 LEDs that can be individually configured. The LED to the left of the display is LED 1 while the one to the right is LED 2.

The following options can be selected when setting the LEDs:

- **Signal Selection:** The following signals can be selected: turbidity 1 and 2.
- Output function, direction of action, switch point entry method, switch point, hysteresis
- **Switch ON Delay, Switch OFF Delay:** The digital output is switched on or off with the delay set here. Values can be set between 0...30 s.
- **Warn-S: no Media, Warn-S: Outside Spec., Err-Sig: Underflow, Err-Sig: Overflow, Err-Sig: Global Failure:** The effect of each parameter on the LED display can be set. The following can be selected: "No Effect on Output", "Output Fast Blinking" (0.4 s interval), "Output Slowly Blinking" (1 s interval), "Output ON" (LED on continuously) and "Output OFF". "Output" refers to the LED here.
- **Signaling Simulation:** The source value is briefly replaced by the entered parameter value. The following situations can be simulated: "Output OFF", "Output ON", "Output Slowly Blinking" and "Output flashes rapidly". "Output" refers to the LED here.

The turbidity sensor is delivered with the following factory settings for the LEDs:

- LED 1 (left LED)
 - If the sensor is in a normal state, this LED is off.
 - Err-Sig: Overflow:** The LED flashes every second if the sensor registers an overrange error. If the sensor is in a normal state, this LED is off.
 - Err-Sig: Temperature Error:** The LED is permanent on if the sensor registers a medium temperature above 130°C permanent.
 - All other errors are indicated while the LED flashes in short intervals.
- LED 2 (right LED)
 - Condition of the switching output:** LED lights up continuously if the presetted turbidity range is attained. The working direction of the switching output and therefore the behavior of the LED can be changed.

6.6 Examples of sensor settings

Several examples of settings that can be created on the User Interface or on the user interface of the PC follow.

6.6.1 Menu structure User Interface

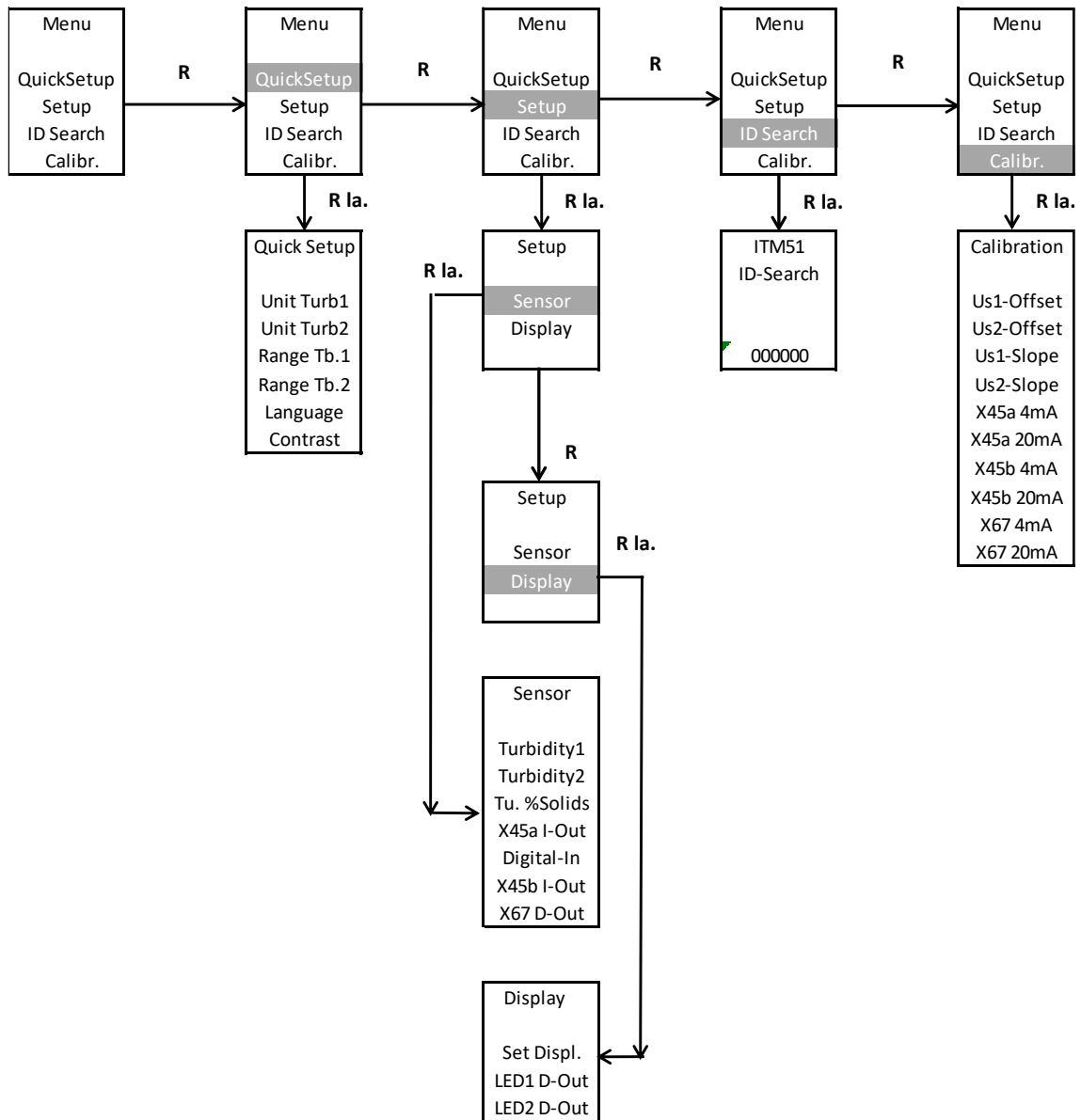

6.6.2 Example for setting turbidity 1 range without an ID code:

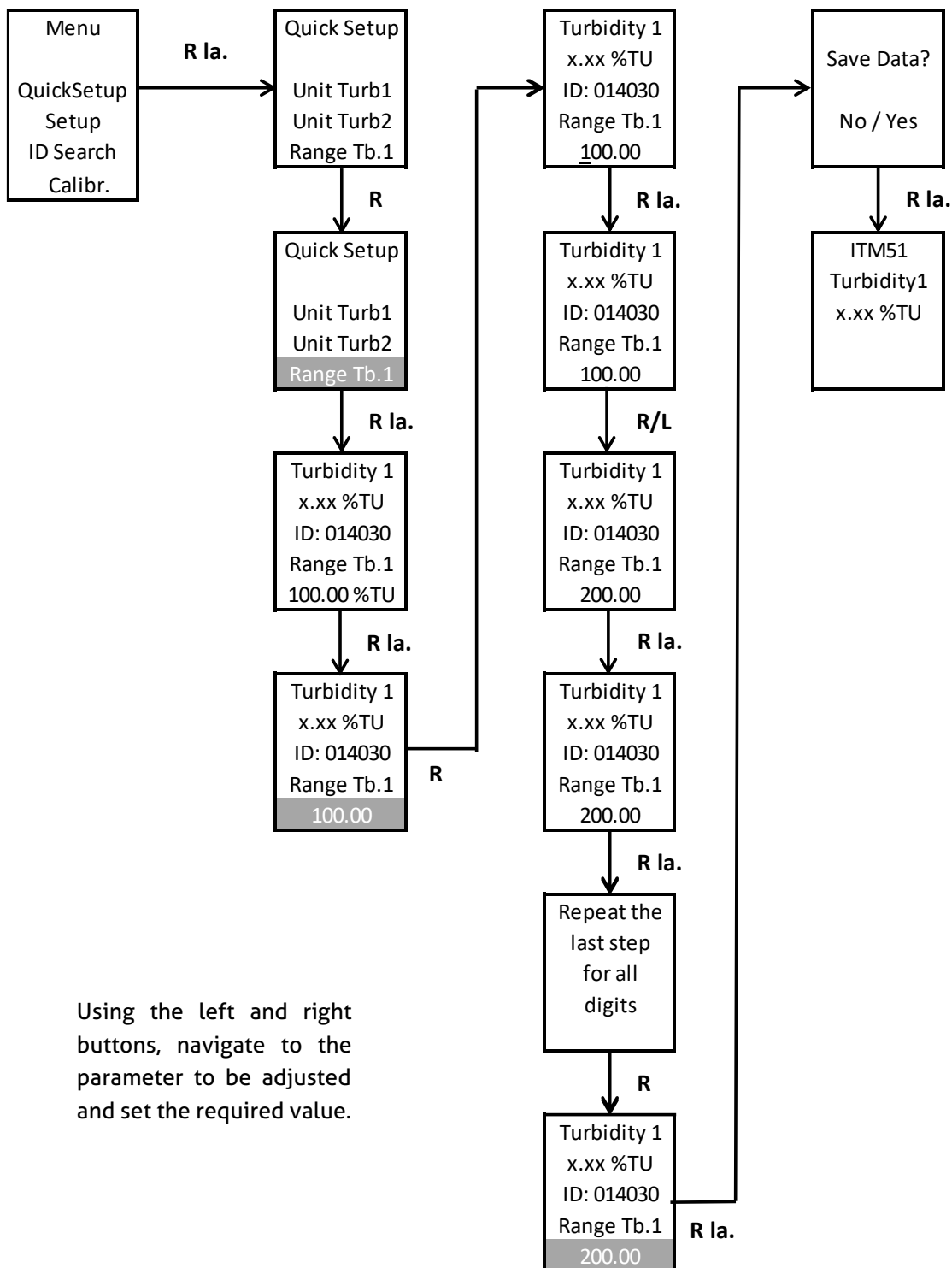

Alternative to entering the measurement range as described above, the measurement range can also be adjusted by entering an ID code.

To do so, go to "YES" on the ID search page and enter the ID code using the buttons. After the code is confirmed, the sensor display shows the menu in which the parameter can be adjusted.

6.6.3 Setting of customer-specific turbidity / %solids curve via PC software

After the PC software is started, a customer-specific curve for the turbidity can be entered via the following node: Turbidity Measurement → % solids → (+). Values need to be entered for at least 2 X and Y points. Up to 8 support points for X and the associated Y values can be entered to establish the relationship between turbidity (X) and % solids (Y). The Y values together with the associated X values form coordinates that act as support points for the linearization curve. If 0 is entered for any of these points, that support point is deactivated.

X-Point 01...X-Point 08 (Turbidity): This parameter is used to define the customer-specific measurement range of the turbidity. Values can be entered from 0...300 kNTU.

Y-Point 01...Y-Point 08 (% solids): This parameter is used to define the customer-specific measurement range. Values can be entered from 0...100%.

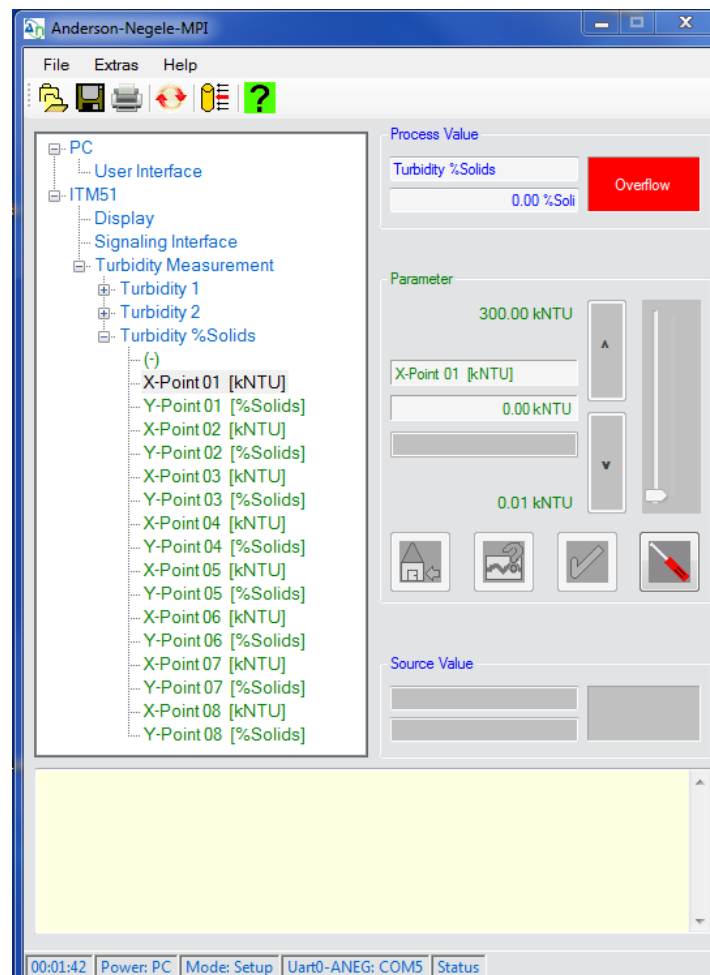

7 Installation of the "Large User Interface" (LUI)

1. Remove the plastic cover (continue with step 4), or remove the puck with the mounted small display (continue with step 2)
2. Remove the small display
3. Install the puck in the sensor head
4. Mount the large display

Hot-plug function: The large display can be installed while the sensor is energized, but this requires the usual precautionary measures when working with electronic components.

If the display is being installed while energized, it is necessary to press both buttons simultaneously for > 10 s after the display is installed to activate the display.

7.1 Retrofitting the display if a display was not yet installed



Remove the plastic cover: To do so, bend the tabs slightly inwards with a screwdriver to be able to remove the cover easily.

After removing the plastic cover, the large display can be inserted in the head of the sensor. The tabs (Fig. 2) must be inserted in the appropriate openings on the puck (Fig. 1). Then the display can be easily pressed onto the puck. No wiring is required.

Note: After the Large User Interface is mounted, the sensor can only be operated on this display since the display conceals the connector for the MPI-200 adapter. If operating the sensor using the programming software is preferred, the display must be removed. Then the connector of the programming adapter can be plugged in.

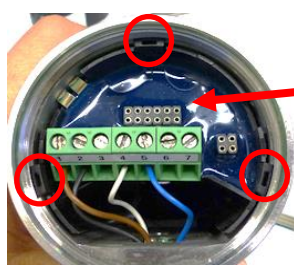

Fig. 1

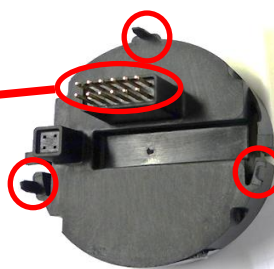

Fig. 2

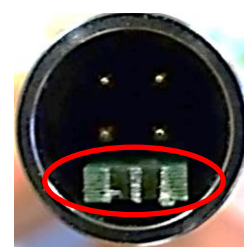

Fig. 3

Attention: The connector of the programming adapter (Fig. 3) must be connected in the correct direction → the green spacer must face the cable exit (M12 connector or PG).

7.2 Retrofitting the display if a small display (SUI) was already installed

First the puck with the mounted display needs to be removed using the puck puller tool (Fig. 1). To do so, detach the wires from the cable terminal. Then insert the five arms of the puck puller in the plastic tabs of the puck (Fig. 2).



Fig. 4

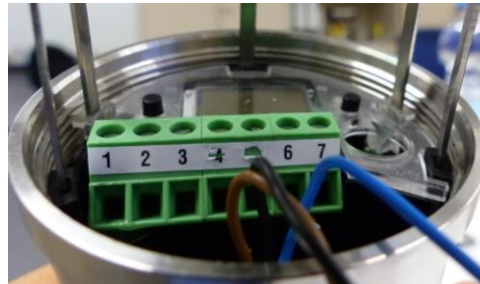
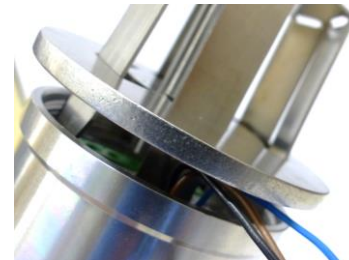

Fig. 5

Push the puck puller all the way into the sensor head and push the disk as far as possible toward the sensor head so that the arms of the puck puller firmly grasp the puck.
 Pull the puck with the display out of the sensor housing and finally pull off the small display from the puck.



Now the puck without the display can be properly positioned and installed back in the sensor head and the wiring can be reconnected to the cable terminal. Then the large display can be mounted → see "Retrofitting the display if a display was not yet installed".

7.3 Operating the large display

The large display (LUI) is operated in the same way as the small display (SUI). It is operated using two operating buttons below the display:



After the sensor is started, the screen saver appears in which the process values of the sensor are displayed one after the other. To reach the start page from here, press one of the two buttons briefly.

8 Dimensions

ITM-51 with vertical head orientation.

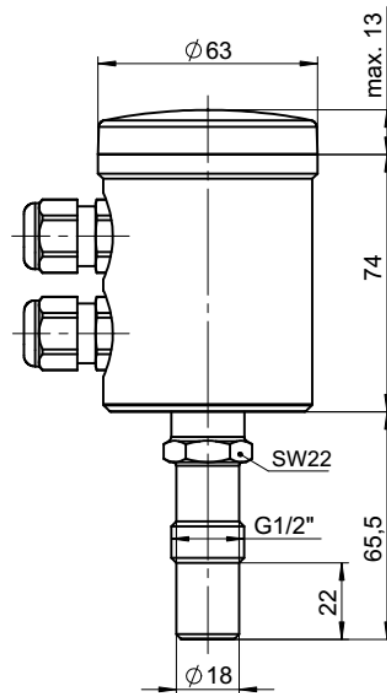

Process Connection

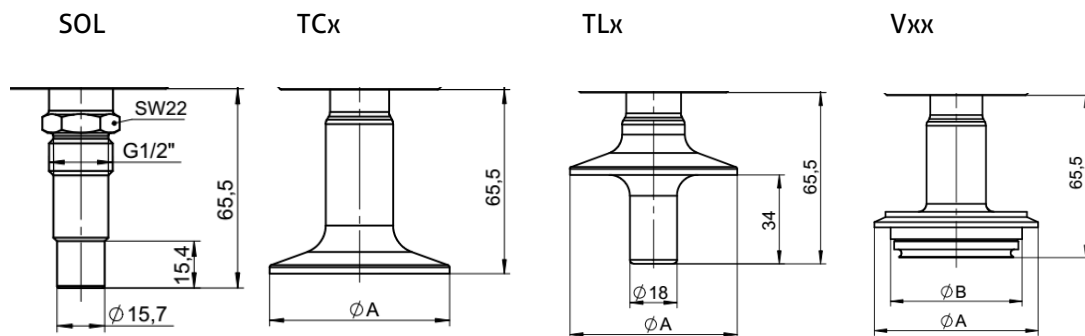

TriClamp size		Varivent size		
Type	Ø A (mm / inch)	Type	Ø A (mm / inch)	Ø B (mm / inch)
TC1 / TL1	50,5 / 1.99	V25	66.0 / 2.60	53.0 / 2.09
TC2 / TL2	64,0 / 2.52	V40	84.0 / 3.31	71.0 / 2.79
T25 / TL5	77,5 / 3.05			
TC3 / TL3	91,0 / 3.58			

ITM-51 with horizontal head orientation.

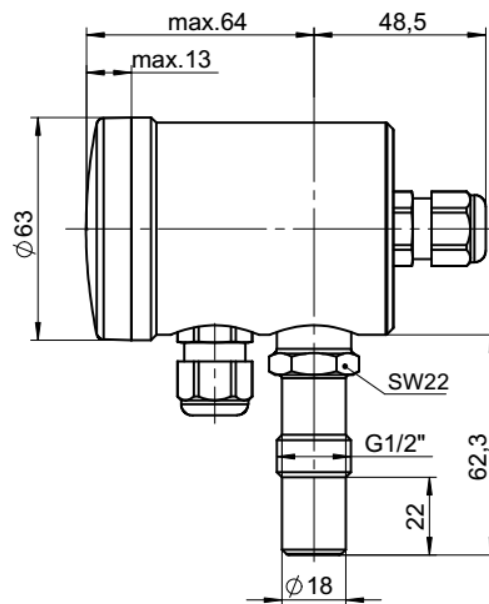

Process connection

SOL

TCx

TLx

Vxx

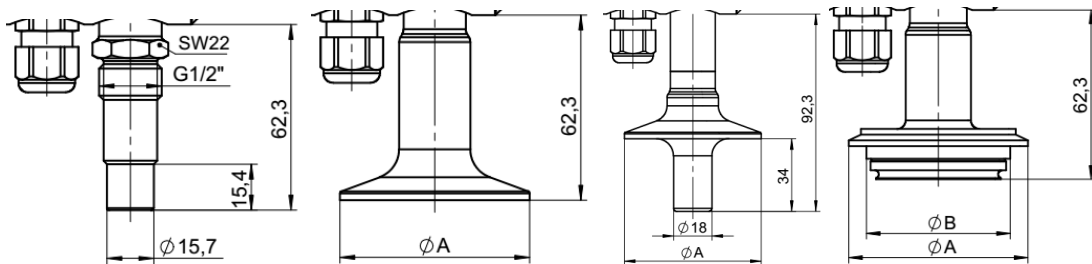

9 Electrical connection cable gland

Connection of cables to terminal strip: required if the puck is removed from the sensor.

Electrical connection with cable gland

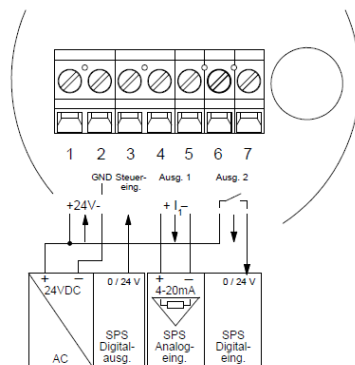

10 Electrical Connection Digital Signal Modules

10.1 Terminal Block of I5x Series

X	I52 / A52	I53 / A53
X1	Power Supply +	
X2	Power Supply -	
X3	IO-Link / not affected	IO-Link / Digital Input X3
X4	Analog Output X45 +	
X5	Analog Output X45 -	
X6	Relay Output 67	
X7	Relay Output 67	

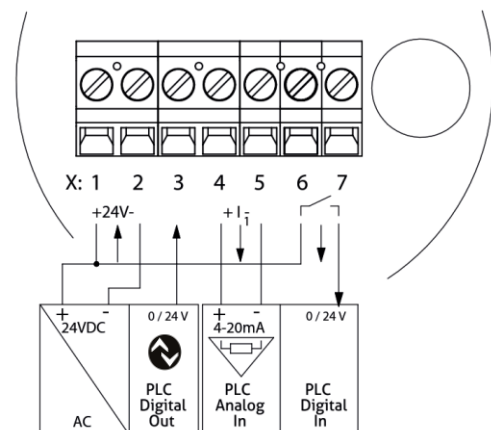

10.2 Terminal Block of I4x Series

X	I42
X1	Power Supply +
X2	Power Supply -
X3	IO-Link
X4	Analog Output X45 +
X5	Analog Output X45 -

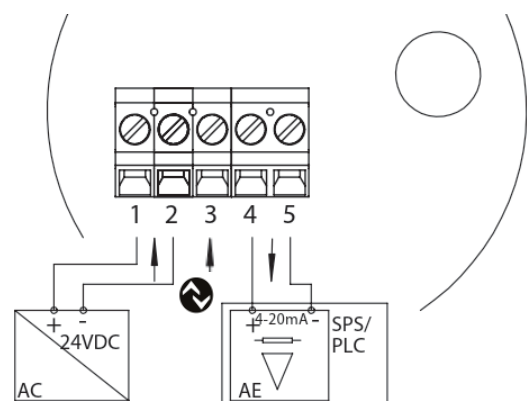



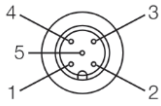



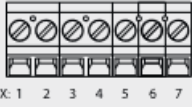

10.3 M12 connector cables color

M12 Connector	Pin	Standard Color	Anderson Color
	1	Brown	Red
	2	White	Black
	3	Blue	Green
	4	Black	Not assigned
	5	Grey	White

10.4 Overview electrical connections

Application / Function	Signal module	I42	I52	I53
IO-Link communication X3		✓	✓	✓
1x 4...20 mA turbidity		✓	✓	✓
1x switch output		✗	✓	✓
1x digital input for external range switching		✗	✗	✓

Table electrical connection						
Type	Connection	Pin assignment				
P (1x PG) D (2x PG)	 x: 1 2 3 4 5 6 7	Clamps	1: Power supply +24 V DC 2: Power supply - 3: Digital input X3 4: Analog output X45 + 5: Analog output X45 - 6: Relay output X67 7: Relay output X67	✓	✓	✓
A (2x M12)		4 pin	1: Analog output X45 - 2: Analog output X45 + 3: Power supply +24 V DC 4: Power supply -	✗	✓	✓
		5 pin	1: Relay output X67 2: Not assigned 3: Not assigned 4: Relay output X67 5: Digital input X3			
M (1x M12)		4 pin	1: Power supply +24 V DC 2: Analog output X45 + 3: Analog output X45 - 4: Power supply -	✓	✗	✗
N (2x M12)		4 pin	1: Analog output X45 + 2: Relay output X67 3: Relay output X67 4: Analog output X45 -	✗	✓	✓
		5 pin	1: Power supply +24 V DC 2: Not assigned 3: Not assigned 4: Power supply - 5: Digital input X3			
C (1x M12) IO-Link		5 pin	1: Power supply +24 V DC 2: Analog output X45 - 3: Power supply - 4: IO-Link 5: Analog output X45 +	✓	✗	✗
R (2x M12) IO-Link		4 pin	1: Analog output X45 + 2: Relay output X67 3: Relay output X67 4: Analog output X45 -	✗	✓	✓
		3 pin	1: Power supply +24 V DC 3: Power supply - 4: IO-Link / Digital input X3			

11 ITM-51 IO-Link Device Identity

▼ Identity

IODD-File: [AndersonNegele-ITM51_I63-20190529-IODD1.1.xml](#)
Copyright: Anderson-Negele
Version: V1.00 / 2019-05-29

Vendor: [Anderson-Negele \(Id: 1138\)](#)
www.anderson-negele.com

Family: Hygienic Turbidity Sensor
Device: ITM51_I63 (Id: 272929)
SIO mode: Supported
Transmission rate: COM2
Minimum cycle time: 51.2 ms
Variant: ITM-51 (Id: 0)
 Hygienic Turbidity Sensor

12 ITM-51 IO-Link Process Data

▼ Maintenance (User Role)		
Parameter	Device	Edit
▼ Process Data		
▼ Process data		
Turbidity 1	6.04	
Turbidity 2	0.45	
Percent Solids	0.00 %	
▼ Identification		
▼ Device Access Locks		
Parameter (write) Access Lock	false	<input type="checkbox"/> Write
Data Storage Lock	false	<input type="checkbox"/> Write
Vendor Name	Anderson-Negele	
Vendor Text	www.anderson-negele.com	
Product Name	ITM51	
Product ID	0	
Product Text	Turbidity Measurement	
Serial Number	00011	
Hardware Version	0.49	
Firmware Version	V01.004	
▼ Parameters		
▼ General		
Display Language »	Deutsch	<input type="checkbox"/> Write
▼ Turbidity 1		
Upper Range Value 1 »	44.7	<input type="text" value="1.0 .. 300.1"/> Write
Unit Turbidity 1 »	%TU	<input type="checkbox"/> Write
▼ Turbidity 2		
Upper Range Value 2 »	25.0	<input type="text" value="1.0 .. 300.1"/> Write
Unit Turbidity 2 »	kEBC	<input type="checkbox"/> Write

12.1 ITM-51 IO-Link Process data description

Name	Description	Data type	Bit length	Bit Offset	Value range	Gradient	Off-set	Unit
Turbidity 1	Value of turbidity 1	Float 32	32	0	0.01 - 300.00 kNTU 0.75 - 75.00 kEBC 0.66 - 197.00 %TU 0.33-100.00 %Soli	1	0	kNTU kEBC %TU, %Solids
Turbidity 2	Value of turbidity 2	Float 32	32	32	0.01 - 300.00 kNTU 0.75 - 75.00 kEBC 0.66 - 197.00 %TU 0.33-100.00 %Soli	1	0	kNTU kEBC %TU, %Solids
% Solids	% solids based on turbidity value	Float 32	32	64	0 - 100 %	1	0	%
Turbidity Base	Value of turbidity base	Float 32	32	96	0.01 - 300.00 kNTU	1	0	kNTU

Process value Turbidity 1 (Bits 0-31)



Process value Turbidity 2 (Bits 32-63)



Process value % Solids (Bits 64-95)



Process value Turbidity Base (Bits 96-127)



On PLC-Input side use data type Float32 as data type for each process value.

12.2 IO-Link Eventlist

Measurement Events

Event Code	Event Type	Event Name (EN)	Event Name (DE)
36285	Warning	Outside specification: Turbidity 1. Currently the sensor is not able to perform a reliable measurement	Außerhalb der Spezifikation: Trübung 1. Derzeit ist der Sensor nicht in der Lage, eine zuverlässige Messung durchzuführen
36286	Warning	Underrange: Turbidity 1	Untersteuerungsgrenze: Trübung 1
36287	Warning	Overrange: Turbidity 1	Übersteuerungsgrenze: Trübung 1
36288	Error	Underflow: Turbidity 1	Unterlauf: Trübung 1
36289	Error	Overflow: Turbidity 1	Überlauf: Trübung 1
36290	Warning	No Media: Turbidity 1. Currently the sensor cannot detect any medium	Kein Medium: Trübung 1. Der Sensor kann derzeit kein Medium erkennen
36291	Error	Fail: Turbidity 1	Fehler: Trübung 1
36292	Warning	Outside specification: Turbidity 2. Currently the sensor is not able to perform a reliable measurement	Außerhalb der Spezifikation: Trübung 2. Derzeit ist der Sensor nicht in der Lage, eine zuverlässige Messung durchzuführen
36293	Warning	Underrange: Turbidity 2	Untersteuerungsgrenze: Trübung 2
36294	Warning	Overrange: Turbidity 2	Übersteuerungsgrenze: Trübung 2
36295	Error	Underflow: Turbidity 2	Unterlauf: Trübung 2
36296	Error	Overflow: Turbidity 2	Überlauf: Trübung 2
36297	Warning	No Media: Turbidity 2. Currently the sensor cannot detect any medium	Kein Medium: Trübung 2. Der Sensor kann derzeit kein Medium erkennen
36298	Error	Fail: Turbidity 2	Fehler: Trübung 2
36299	Warning	Outside specification: Percent Solids. Currently the sensor is not able to perform a reliable measurement	Außerhalb der Spezifikation: Prozent-Feststoffgehalt. Derzeit ist der Sensor nicht in der Lage, eine zuverlässige Messung durchzuführen

36300	Warning	Underrange: Percent Solids	Untersteuerungsgrenze: Prozent-Feststoffgehalt
36301	Warnung	Overrange: Percent Solids	Übersteuerungsgrenze: Prozent-Feststoffgehalt
36302	Error	Underflow: Percent Solids	Unterlauf: Prozent-Feststoffgehalt
36303	Error	Overflow: Percent Solids	Überlauf: Prozent-Feststoffgehalt
36304	Warning	No Media: Percent Solids. Currently the sensor cannot detect any medium	Kein Medium: Prozent-Feststoffgehalt. Der Sensor kann derzeit kein Medium erkennen
36305	Error	Fail: Percent Solids	Fehler: Prozent-Feststoffgehalt
36306	Warning	Outside specification: Turbidity Base. Currently the sensor is not able to perform a reliable measurement	Außerhalb der Spezifikation: Trübung Basis. Derzeit ist der Sensor nicht in der Lage, eine zuverlässige Messung durchzuführen
36307	Warning	Underrange: Turbidity Base	Untersteuerungsgrenze: Trübung Basis
36308	Warning	Overrange: Turbidity Base	Übersteuerungsgrenze: Trübung Basis
36309	Error	Underflow: Turbidity Base	Unterlauf:Trübung Basis
36310	Error	Overflow: Turbidity Base	Überlauf: Trübung Basis
36311	Warning	No Media: Turbidity Base. Currently the sensor cannot detect any medium	Kein Medium: Trübung Basis. Der Sensor kann derzeit kein Medium erkennen
36312	Error	Fail: Turbidity Base	Fehler: Trübung Basis
36341	Error	No Sensor Connected	Kein Sensor angeschlossen
36342	Error	General Error. The sensor indicates a general error	Gerätefehler. Der Sensor meldet einen allgemeinen Fehler
36343	Error	Clipping Error	Übersteuerungsfehler
36344	Error	LED defect	LED defekt
36345	Error	Receiver defect	Empfänger defekt

36346	Error	Reference Error	Referenzfehler
36347	Error	Leakage Error	Leckage Fehler
36348	Error	Temperature Error	Temperaturfehler
36349	Error	Bootloader active	Bootloader aktiv

13 Repair and maintenance

The turbidity sensor described here is maintenance-free. However, it is recommended to check the calibration of the turbidity sensor once a year. For this check the ITM-51-CU calibration check tool is recommended.

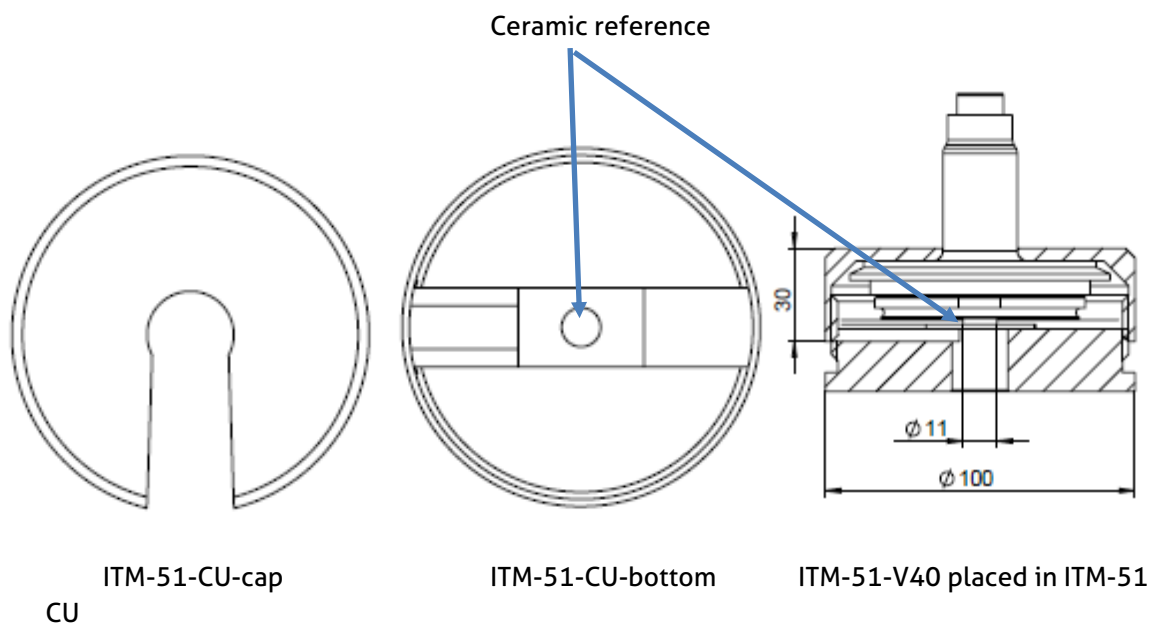

The ITM-51-CU unit is used as below:

1. Cleaning the lens. The lens must be free of residues and scratches.
2. Changing the measurement category to NTU
3. Setting the upper range limit to 300 kNTU
4. Placing the ceramic reference plate in the bottom piece according to the ITM-51 process connection. Fitting types TLx and Sox are placed from bottom and centered automatically. Fitting type TCx and Vxx are placed on top as shown in the drawing above. The centering is done while screwing the cap on to the bottom piece.
5. Checking the displayed NTU value and compare with the reference value printed on the label of ITM-51-CU. The value needs to be within the range of $\pm 6\%$ as printed on the label as well.
6. If the displayed value is outside the limits it is recommended to send back the ITM-51 for recalibration.

14 Technical data

Measurement category	The measurement category can be selected	%TU, NTU, EBC, %solids (customized)								
Measurement range	The measurement range is freely adjustable	0...300.000 NTU equivalent 0...200 %TU 0...75.000 EBC								
Process connection		CLEANadapt G1/2" hygienic Tri-Clamp 1.5", 2", 2.5", 3" Varivent DN 25 (type F) DN 40/50 (type N)								
Process pressure		-1...50 bar / -14...750 psi								
Tightening torque		20 Nm (CLEANadapt system)								
Materials	Connecting head Sensor Lens Plastic cover/sight glass	Stainless steel 1.4308 (CF-8) Stainless steel 1.4404 (316L) Sapphire Polycarbonate								
Temperature ranges	Ambient Process CIP/SIP	-10...60°C / 14...140 °F -10...130°C / 14...266 °F Up to 140°C / 284 °F max. 120 min								
Reproducibility	of turbidity	$\leq 1\%$ of upper range limit								
Resolution/measurement range	the resolution is dependent on the selected measurement range	<table border="0"> <tr> <td>range/ NTU</td> <td>resolution/ NTU</td> </tr> <tr> <td>< 1 000</td> <td>15</td> </tr> <tr> <td>1 000...10000</td> <td>30</td> </tr> <tr> <td>10000...100000</td> <td>100</td> </tr> </table>	range/ NTU	resolution/ NTU	< 1 000	15	1 000...10000	30	10000...100000	100
range/ NTU	resolution/ NTU									
< 1 000	15									
1 000...10000	30									
10000...100000	100									

Accuracy	200...9.999 NTU	±3 % from measurement value; ±50 NTU offset
	10.000...300.000 NTU	±5 % from measurement value
Long-term stability	±0,2 %	from measurement value
Response time	for turbidity measurement	0,75 s
Measurement principle	infrared backscatter	wave length 860 nm
Electrical connection	Cable gland	2 x M16 x 1.5
	Cable connection	2 x M12 connector 1.4305
	Supply voltage	18...36 V DC max. 190 mA
	Protection class	IP 69K
Output	Analog	1x analog output 4...20 mA, potential-free, 1x relay output potential-free
	Digital	1x digital input (24 V DC), short-circuit proof IO-Link v1.1
Weight		750 g

Note

The contents of this document are the intellectual property of Anderson-Negele. Any reproduction or translation without written permission is prohibited.

Please read these installation and operating instructions carefully. All instructions in this manual must be followed exactly to ensure proper operation of the unit.

If you have any questions regarding the product, installation or commissioning, please contact Anderson-Negele Support at support under:

America:
 Phone 800-833-0081
 techservice@anderson-negele.com

Other countries:
 Phone +49-8333-9204720
 support@anderson-negele.com

