

Instruction Manual



ANDERSON-NEGELE

Anderson Instrument Co. Inc.
156 Auriesville Road
Fultonville, NY 12072
1-800-833-0081
Fax 518-922-8997
www.anderson-negele.com

Instrument Model Number _____

Instrument Serial Number _____

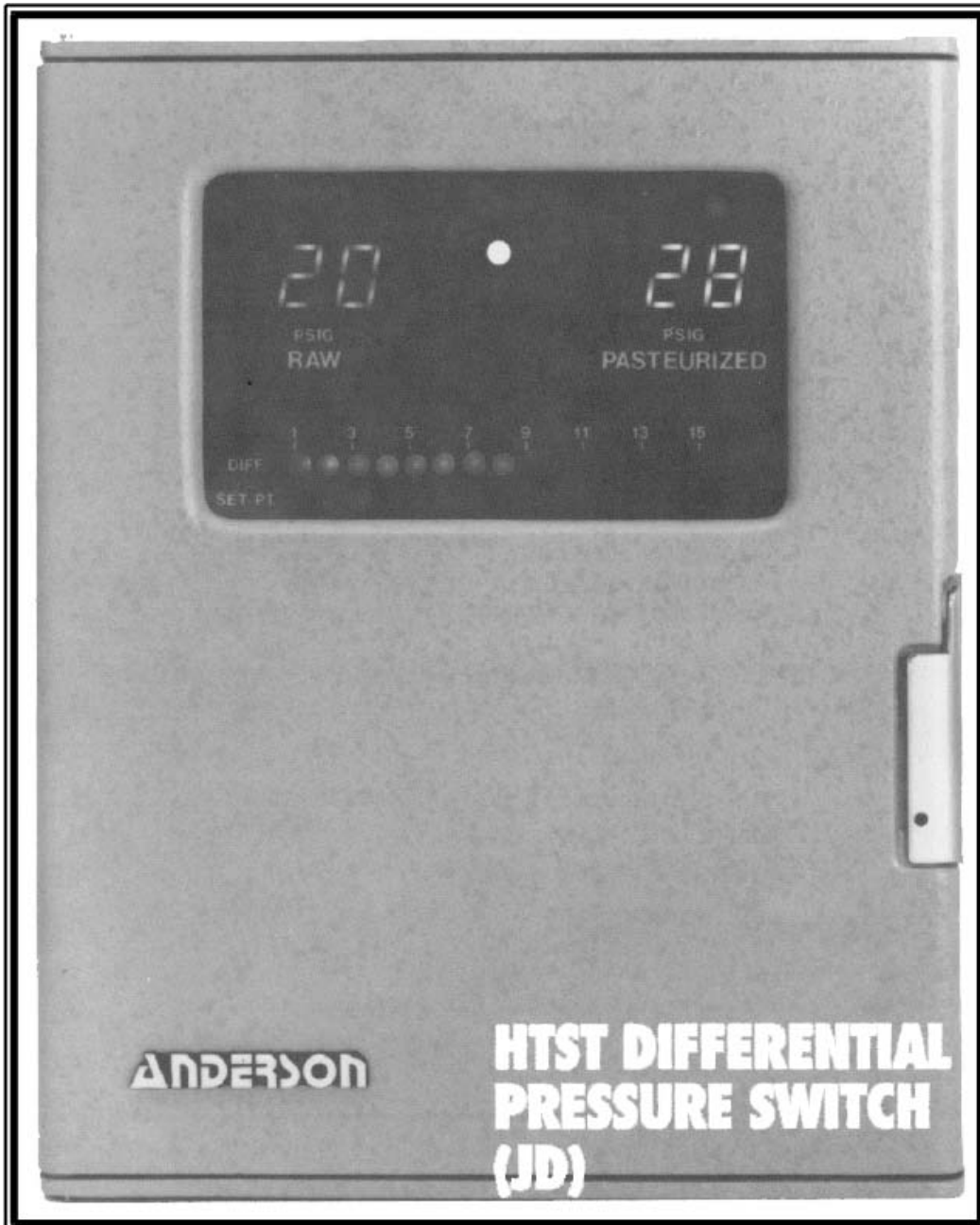

Form Number AIC3410
© October 1997
Rev. November 2004

Table of Contents

Section 1 - General	Page
1.1 DESCRIPTION	3
1.2 SPECIFICATIONS	4
1.3 TYPICAL SYSTEM APPLICATION	4
Section 2 - Installation	
2.1 PRESSURE SENSOR LOCATION	5
2.2 INSTRUMENT CASE	6
2.3 ELECTRICAL WIRING	7
2.3.1 Interconnection With Other HTST Components	7
2.3.2 Power Supply	8
2.3.3 Booster Pump Switch	8
2.3.4 Input Signal Connections	9
2.3.5 Transmitter Signal Connections	10
2.3.6 4-20 mA Output Wiring	11
Section 3 - Operation	
3.1 PRINCIPLES OF OPERATION	11
3.2 ADJUSTMENT OF DIFFERENTIAL PRESSURE SET POINT	12
3.3 HIGH PRESSURE LIMIT SWITCH	13
3.3.1 Display of Limit Switch Set Point	13
3.3.2 Changing the Limit Switch Set Point	13
3.4 TEST BUTTONS	13
Section 4 - Test and Calibration	
4.1 TEST PROCEDURES	14
4.2 CALIBRATION ADJUSTMENTS	15
4.3 CALIBRATION PROCEDURE	17
4.4 CALIBRATION OF 4-20mA OUTPUTS	17
Section 5 - TROUBLESHOOTING	
5.1 TROUBLESHOOTING	18
Appendix A - J-Series Motherboard Schematic	21
Appendix B - Spare Parts List	22
Appendix C - Warranty and Return	23

Section 1 General

1.1 DESCRIPTION

The JD series Differential Pressure Switch is an all-electronic, solid-state instrument that complies with all applicable USPH codes. The instrument senses raw and pasteurized product pressures and displays them in bright 1/2" LED numerals. The differential is calculated and displayed on the bargraph as is the adjustable setpoint. The control relay allows the booster pump to run only when the selected differential is maintained. An externally visible LED indicates when the pump is running.

The electronic pressure transducers and transmitters are available in various sanitary connections and comply with applicable 3-A standards.

The instrument is supplied in an aluminum (200-series) case for flush mounting in panels, or wall mounting. A high pressure limit switch is present on the pasteurized product channel. This can be used to alleviate the need for a time delay on the booster pump, or for alarm purposes.

The instrument cover has provision for a wire seal by the local health inspector.

FIGURE 1

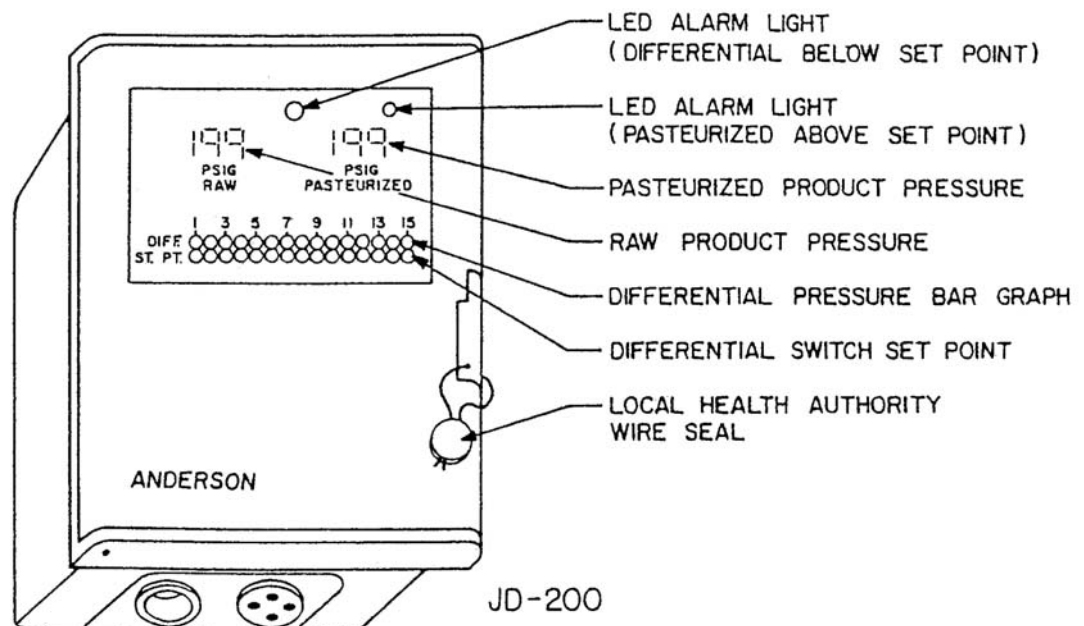

1.2 SPECIFICATIONS (Differential Pressure Switch Only)

Process Pressure Range:	-10 to +99 psig standard (-10 to +199 psig, 0-9.9 Bar, 0-19.9 Bar optional)
Accuracy*:	± 1.0% of full scale
Adjustable Low Differential Pressure Set Point Range:	1-15 psid standard 5-75 psid, 0.1-1.5 Bar optional (in 5 psid increments)
Contact Rating:	5 amps, 120 or 240 Volts AC or DC, resistive or inductive load; on differential and pasteurization channels
Housing Ambient Temp. Limits:	30-130°F
Power:	120 VAC standard 240 VAC optional; 50-60Hz
4-20mA outputs:	proportional to raw, pasteurized, or differential pressure (any two of the three) built in power supply, 500 ohms maximum loop resistance
High pressure limit switch set point range:	0-99 psig (0-199 psig, 0-9.9 Bar, 0-19.9 Bar optional) (on pasteurized channel only)

* *Factory calibrated with provision for field adjustment*

1.3 TYPICAL SYSTEM APPLICATION

The use of the HTST Differential Pressure Switch is shown in a typical HTST (High Temperature Short Time) pasteurizing system in Figure 2. When a Booster Pump is utilized to supplement the Timing Pump, requirements include the installation of a Differential Pressure Switch as shown. The switch senses the pressure differential in a regenerator between raw (cold) and pasteurized (hot) product, to assure that pasteurized product pressure is at least one (1) psi greater than raw product pressure, so that any internal leakage in the Regenerator will not inadvertently contaminate the pasteurized product. Should the pressure differential fall below the switch set point, the switch must shut off the Booster Pump.

A manual or automatic Back Pressure Valve (located before or after the Vacuum Breaker) is frequently utilized to develop additional pressure on the pasteurized product side.

FIGURE 2 TYPICAL HTST PASTEURIZATION SYSTEM

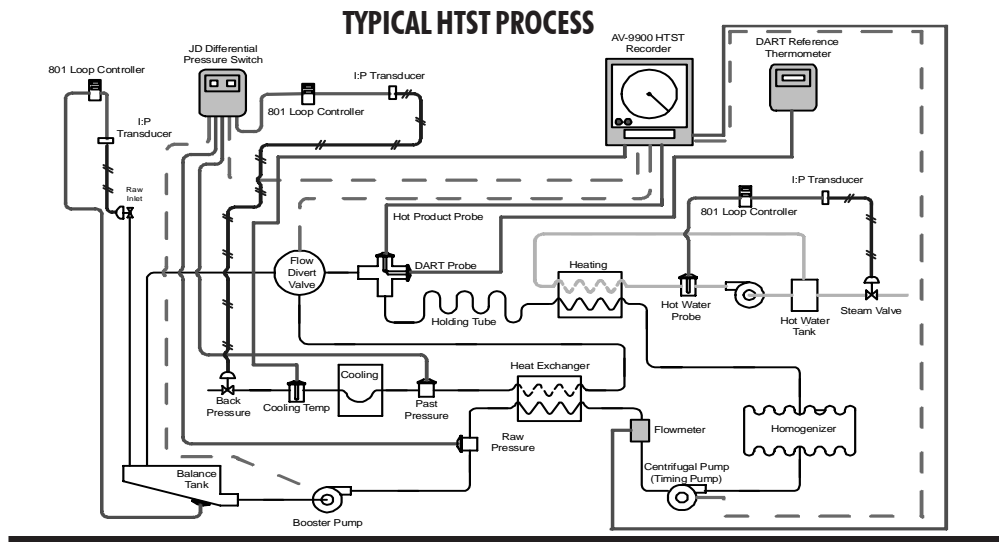

Section 2 Installation

2.1 PRESSURE SENSOR LOCATION

As shown in Figure 1 and Figure 2 of a typical HTST pasteurization system, the raw product pressure sensor is located before the inlet to the cold side of the Regenerator, and the pasteurized product pressure sensor is located after the outlet on the hot side of the Regenerator.

A locator on a straight run of piping or before a bend is preferable to a location on a bend or immediately after a bend, as shown in Figure 3.

Warning: *The sanitary diaphragm of the pressure sensor should be handled carefully during installation and removal to prevent denting which can affect calibration, or rupturing resulting in loss of fill. Keep protective cap in place over diaphragm until installation.*

FIGURE 3 PRESSURE SENSOR LOCATION

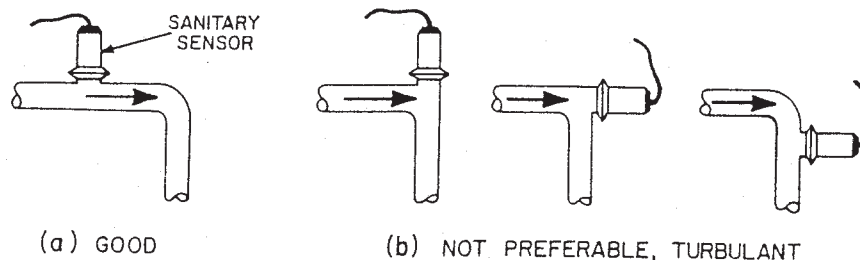

2.2 INSTRUMENT CASE

2.2.1 Location

Select a location for the instrument which is accessible, clean and free from excessive vibrations as well as from wide variations in temperature. The instrument should be mounted vertically on a rigid support or in a panel. Local codes must be observed where they apply.

2.2.2 Mounting

Wall mounting dimensions are shown below. For panel mounting instruments, adjustable clamp-type mounting brackets are supplied. The brackets are reversible for change to surface (wall) mounting.

FIGURE 4 MOUNTING DETAIL FOR J-200 SERIES CASE

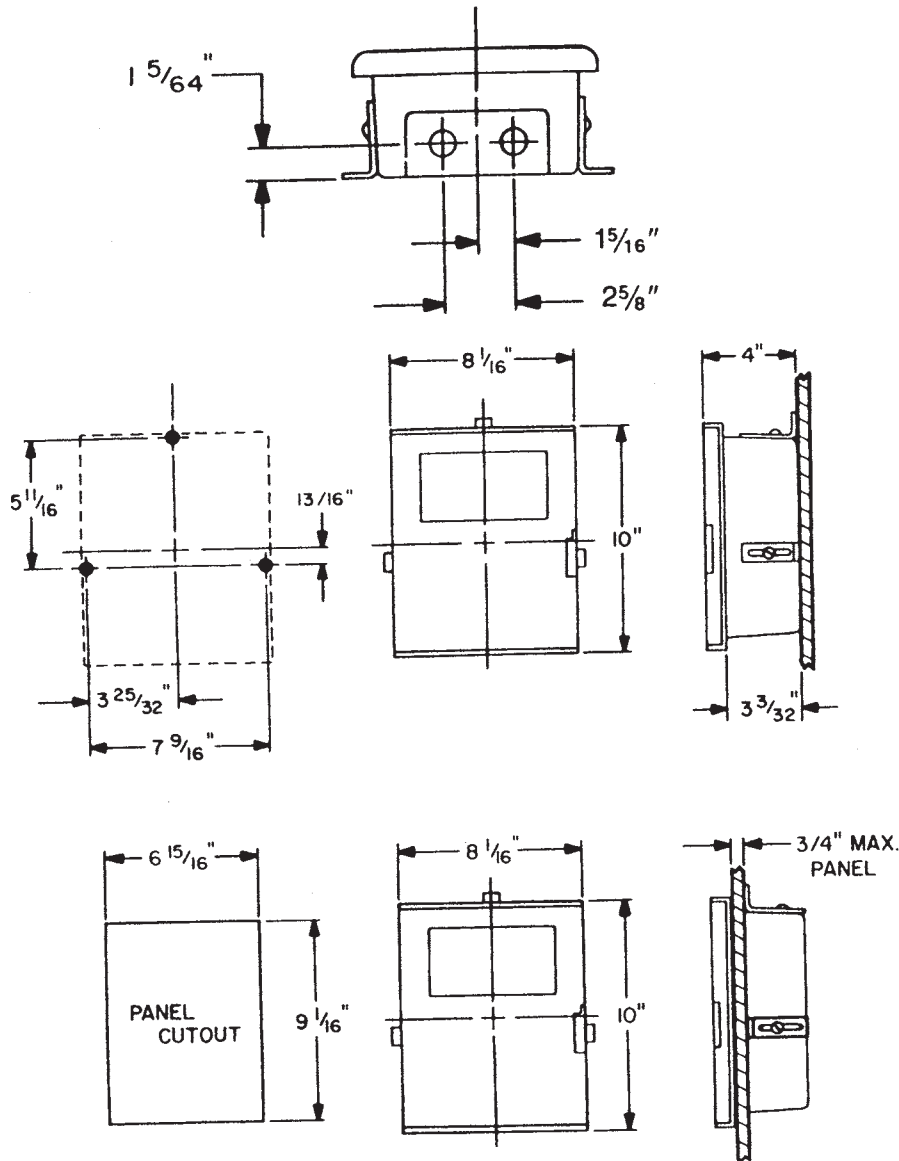

2.3 ELECTRICAL WIRING

2.3.1 Interconnection with other HTST Components

A functional representation of the HTST Differential Pressure Switch, as interconnected with other components of the HTST process is shown in Figure 5. The connection terminal numbering of 1-5 (shown) corresponds to general industry numbering standards.

A time delay relay may be placed in series with the JD Booster Pump relay and Booster Pump starter. The relay reduces the risk of cycling that may occur during startup of the system. As the system moves toward operating pressure, the Flow Diversion Valve moves from Divert to Forward flow, rapid pressure changes may occur. Resulting cycling may cause premature failure of the Booster Pump starter circuitry. Recommended components are shown below. Both provide adjustable closure delay of one (1) to ten (10) seconds on a 10 amp secondary capacity.

- 120 VAC, 50-60 Hz - Use Potter & Brumfield Model CHB-38-70001 or equivalent
- 240 VAC, 50-60 Hz - Use Potter & Brumfield Model CHB-38-80001 or equivalent

Alternately, the adjustable on-board high pressure limit switch may be utilized to prevent cycling inherent at startup. The Booster Pump relay is wired in series with the high pressure limit switch, set to trip just below the normal pasteurized operating pressure. This will prevent the Booster Pump from starting until normal system back-pressure is developed, thus eliminating the need for a time delay relay.

If the high pressure limit switch is not being utilized, another typical application is to prevent freeze up of the cooling section. Most systems will have the pasteurized sensor placed at the outlet of the regenerating section, and the inlet of the cooling section. The high pressure limit switch is set to a maximum safe operating value, with the contacts being wired to the cooling pump. If the high alarm is reached, as in a freeze up condition, the cooling pump will automatically stop until pressures return to a safe operating zone.

FIGURE 5 INTERCONNECTIONS

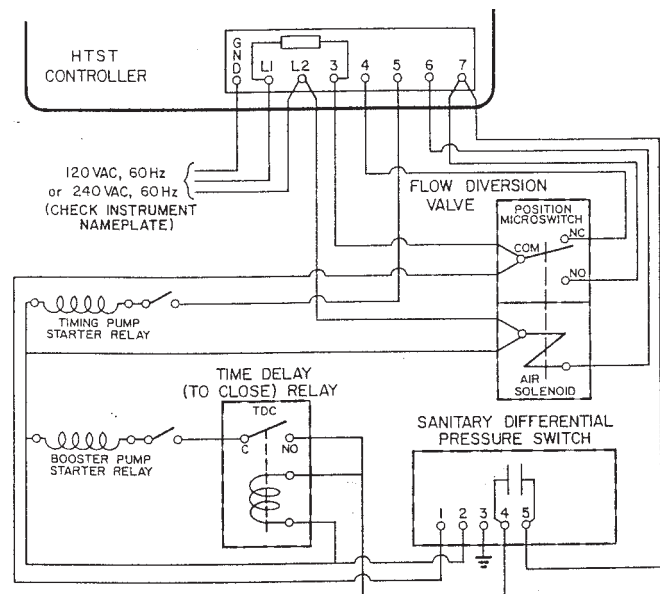

2.3.2 Power Supply

The HTST is powered by either 120 or 240 VAC, 50-60Hz.

WARNING: Check the instrument nameplate for the specific rating before connecting to power source. Current draw is less than 1/4 amp, so 18 AWG, 2-conductor with ground instrument wire is sufficient. Power connections are made to terminals 1, 2 and 3 of the instrument strip inside the bottom of the case as shown in Figure 6.

FIGURE 6 HTST DIFFERENTIAL PRESSURE SWITCH WIRING CONNECTIONS

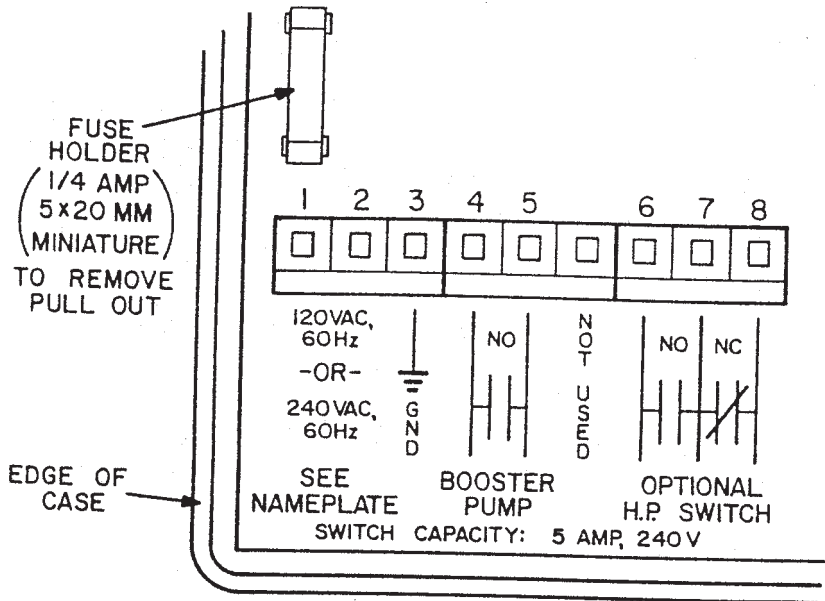

2.3.3 Booster Pump Switch

The Booster Pump Starter Relay circuit is connected in series through terminals 4 and 5 of the terminal strip as shown in Figure 5. The switch between these terminals, is normally open (NO) when the differential pressure between pasteurized and raw product is below the adjustment set point (see Section 3.1).

WARNING: Do not connect the Booster Pump to itself through the switch, as the switch rating of 5 amps will be exceeded.

NOTE: For failsafe operation, the HTST Differential Pressure Switch has been designed so that interruption of power to the instrument will de-energize and throw it into its open position thereby shutting off the Booster Pump.

When utilizing the optional high pressure limit switch to protect the Booster Pump Starter, simply wire a jumper between 4 and 7, and wire the pump through the Normally Closed (NC) contacts on relay K-2 as shown in Figure 7.

NOTE: Relay K-2 is a SPDT relay and may be wired as an alarm contact, independent of the Booster Pump relay.

FIGURE 7 HTST DIFFERENTIAL PRESSURE SWITCH WIRING with OPTIONAL HP LIMIT SWITCH

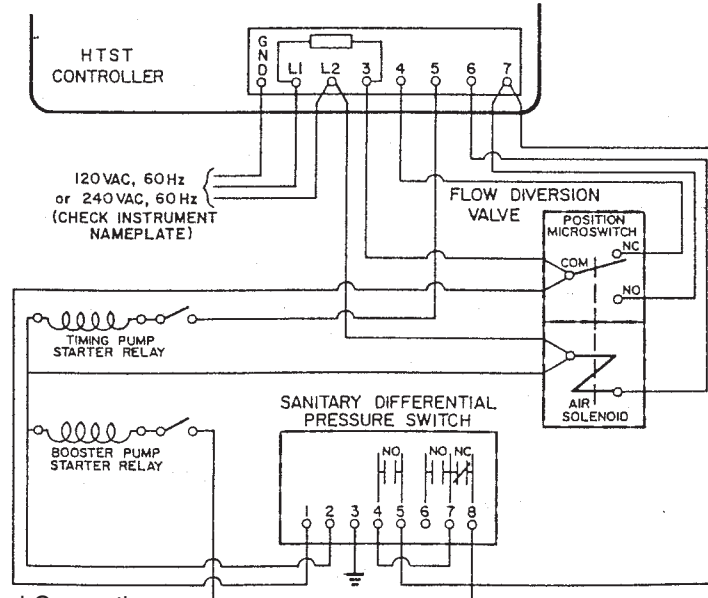

2.3.4 Input Signal Connections

The instrument is shipped with sensors pre-wired and calibrated. In the event that the wires are removed for installation, they should be reattached as shown below in Figure 8. Access to the terminal blocks is gained by removal of the two right side thumbscrews on the display board, and pivoting the board away. If leads are shortened, they should be re-tinned before wiring.

FIGURE 8 SIGNAL INPUT CONNECTIONS

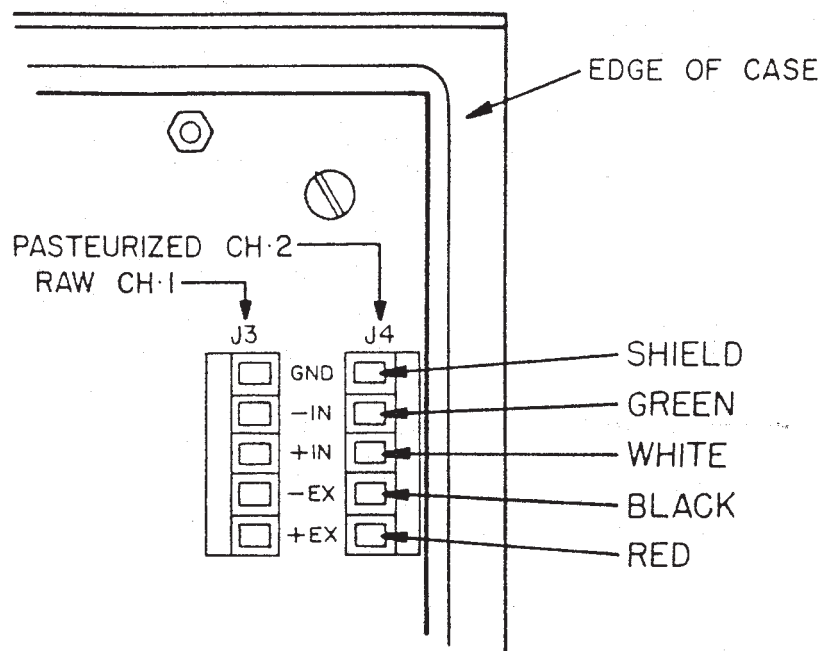

TRANSDUCER INPUT CONNECTIONS

2.3.5 Transmitter Signal Connections

The Instrument is shipped with sensors pre-wired and calibrated. In the event that the wires are removed for installation, they should be re-attached as shown below. Access to the terminal blocks is gained by removal of the two right side thumbscrews on the display board, and pivoting the board away. If leads are shortened, they should be re-tinned before wiring.

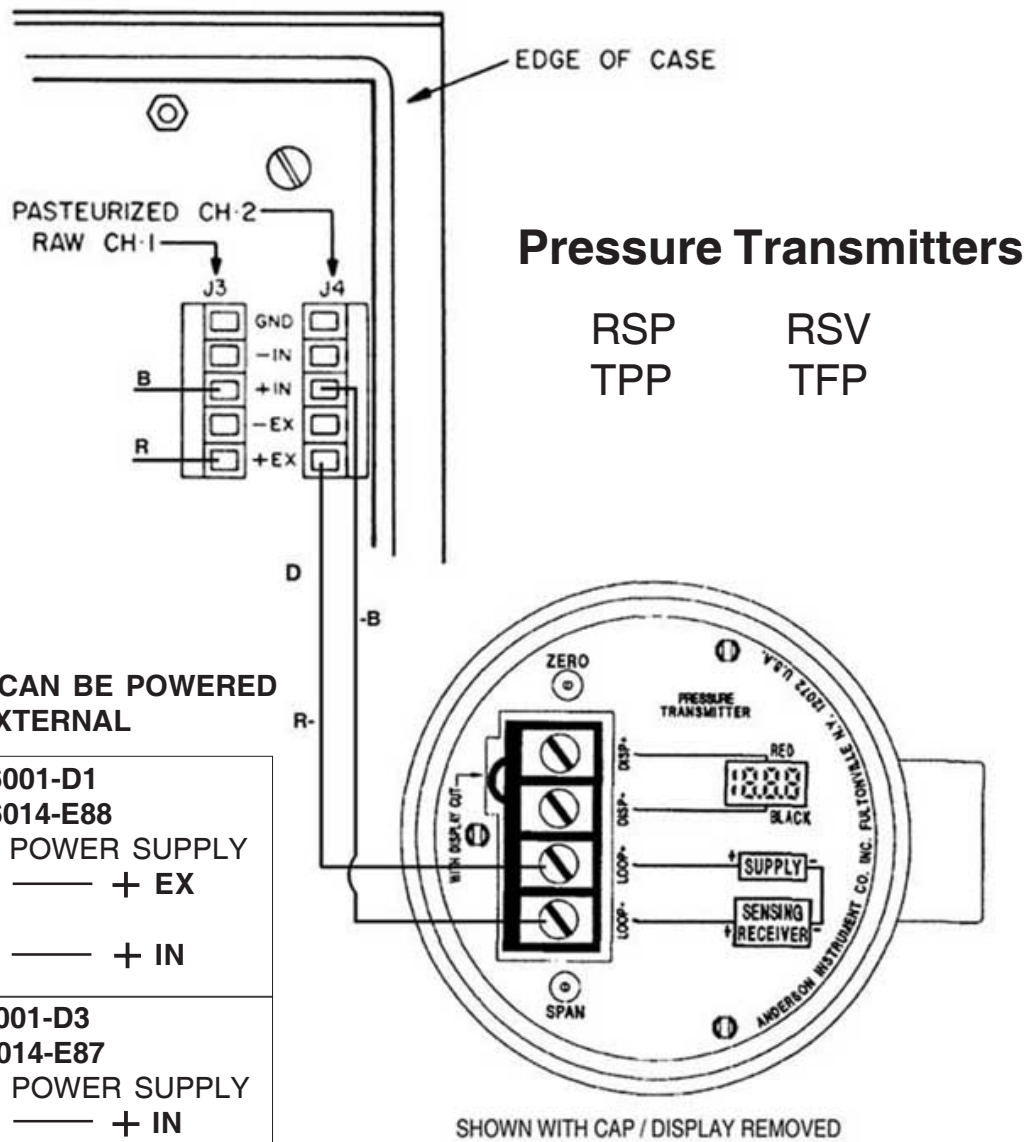

TRANSMITTERS CAN BE POWERED INTERNAL OR EXTERNAL

<p>INPUT CARD 56001-D1 56014-E88 INTERNAL POWER SUPPLY LOOP + ——— + EX LOOP - ——— + IN</p>
<p>INPUT CARD 56001-D3 56014-E87 EXTERNAL POWER SUPPLY LOOP + ——— + IN LOOP - ——— - IN</p>

2.3.6 4-20 mA Output Wiring

If utilizing the 4-20 mA retransmission outputs, they can be wired as shown below.

NOTE: These inputs are non-isolated and cannot be wired with one leg grounded as in some programmable controllers designed for single ended inputs.

NOTE: If interface boards are to be removed to facilitate wiring, turn power off before pulling boards. Be careful to align boards properly, with adjustment "pots" to the left.

FIGURE 9 4-20mA OUTPUT CONNECTIONS

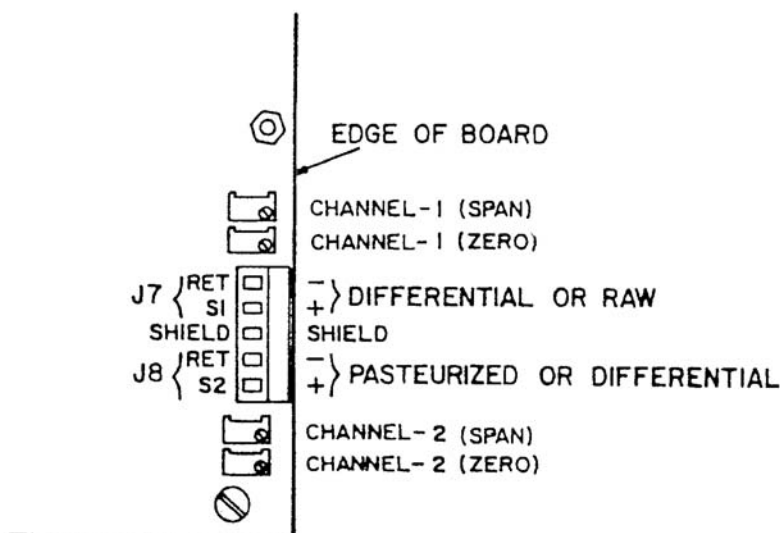

Section 3 OPERATION

3.1 PRINCIPLES OF OPERATION

Four wire, millivolt sanitary pressure transducers are typically used to sense pressure at raw product inlet and pasteurized product outlet of the regenerator. These signals are amplified to a proportional 0-1 volt input by the interface cards within the unit. These interface cards also develop the 10 volt excitation for the sensors. The proportional 0-1 volt signals reach the upper display board via the ribbon connector where the Analog-to-Digital converters condition the signal actuating the displays.

The 0-1 volt inputs are also fed to a computer circuit on the display board which in turn actuates the differential bar graph. A second comparator compares this value to the setpoint and actuates the Booster Pump switch contact (K-1).

An optional third comparator on the pasteurized product channel actuates the high pressure limit switch (K-2).

Additional output circuitry on the lower "power" board provides two-wire, 4-20 mA transmitter outputs proportional to either input, or the differential. Only two (2) of the three (3) outputs are available in any unit.

3.2 ADJUSTMENT OF DIFFERENTIAL PRESSURE SET POINT

In order to adjust the low limit set point of the differential pressure switch, the case door must be opened, thereby requiring the breaking of the seal attached to the door by the local health authority.

The set point can be set in one (1) psi increments from 1 to 15 psid simply by relocating the jumper (located under the bar graph of red LEDs), into the corresponding socket, as shown in Figure 10.

Insert the jumper with its arrow oriented upward. Erroneous insertion (pointed sideways), or no insertion, will inactivate the Differential Pressure Switch so that the switch will remain open and the Booster Pump cannot be turned on.

The set point selected is shown by a single red LED on the lower bargraph. The actual differential pressure to the nearest whole number is shown on the horizontal bar graph above the set point LEDs.

When the differential pressure is above the set point, the green LED light (F) is turned on to indicate the Booster Pump switch is energized. When the differential pressure is below the set point, the red LED light is turned on to indicate the Booster Pump switch is de-energized. These LEDs are located between the raw and pasteurized display, as shown in Figure 11.

NOTE: For units with the optional 5-75 psi differential range, each LED equals a 5 psi increment.

FIGURE 10 LOW LIMIT SET POINT INDICATOR FOR THE DIFFERENTIAL PRESSURE SWITCH

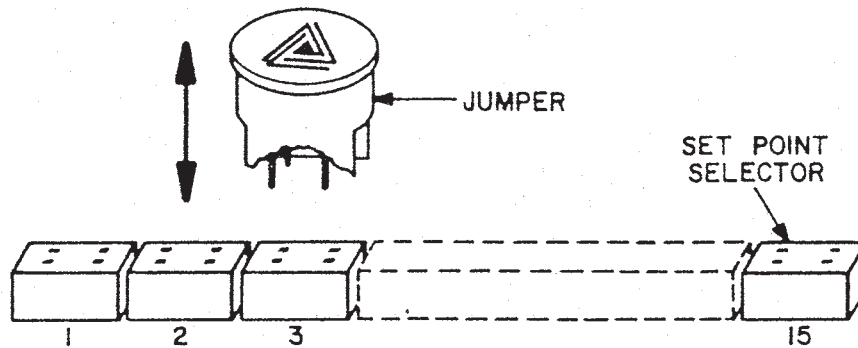
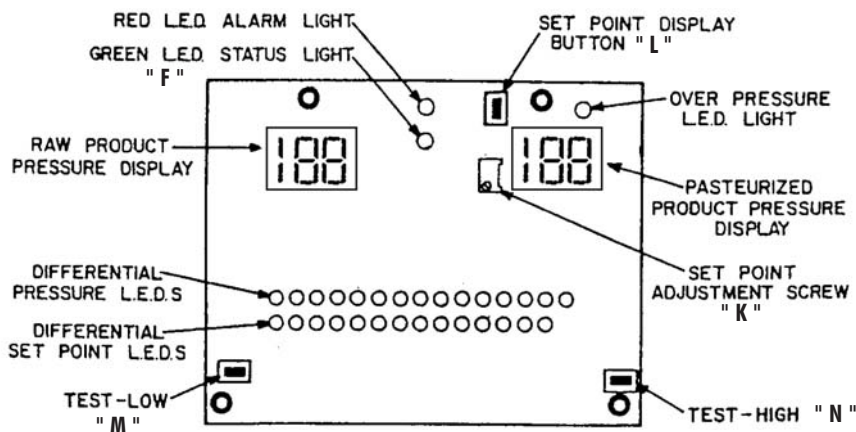

FIGURE 11 DISPLAY CIRCUITRY AND ADJUSTMENTS (DOOR OPEN)

3.3 HIGH PRESSURE LIMIT SWITCH

3.3.1 Display of Limit Switch Set Point

To check the value of the limit switch set point, push the button (L) on the display board as shown in Figure 11. The display will change from the present measured pressure, to show the present set point.

3.3.2 Changing the Limit Switch Set Point

To change an existing set point, open the case door and push the button as above to display the existing set point. While holding the display button down, turn the adjustment screw (K) per Figure 11 (using a jewelers type screwdriver) until the desired set point is displayed. Release the button.

3.4 TEST BUTTONS

Two test buttons (M,N) are provided inside the case door at the left and right corners of the display board, as shown in Figure 11. Checking the instrument can be done when the inspector breaks the seal.

If the differential pressure is below the switch set point, momentarily depressing the right side button (N) labeled "Test High" will simultaneously (a) test the proper functioning of the switch to close and (b) test the operation of the Booster Pump, provided other requirements for pump operation besides a closed differential switch are satisfied.

Note: Green light will not illuminate.

If the differential pressure is already above the switch set point, depressing the right side "Test High" button will *not* change the closed switch position.

If the differential pressure is above the switch set point, momentarily depressing the left side button (M) labeled "Test Low" will simultaneously (a) test the proper functioning of the switch to open by applying a zero differential pressure signal, thereby turning off the differential pressure bar graph, and lighting up the red differential pressure switch status light, and (b) shut off the Booster Pump, if running with other requirements met.

If the differential pressure is already below the switch set point, depressing the left side "Test Low" button will *not* change the open switch position.

Section 4 Test and Calibration

4.1 TEST PROCEDURES

This test procedure is written only as a guideline and is not intended to replace the test procedure in the USPH, Pasteurized Milk Ordinance. The test is designed to check the accuracy of both sensors, accuracy of the differential indicator, and operation of the differential switch and relay.

SPECIFICATIONS

Sensor accuracy: $\pm 1.0\%$ of Full Scale

Differential accuracy $\pm 1.0\%$ of Full Scale

Apparatus

1. A known accurate pressure gauge with accuracy greater than or equal to 1/2 of 1.0% of a 0-100 psi scale
2. A pneumatic testing device which will provide two isolated sanitary pressure connections and a port for the test gauge. A typical apparatus is shown in Figure 12.

FIGURE 12 PNEUMATIC TESTING DEVICE

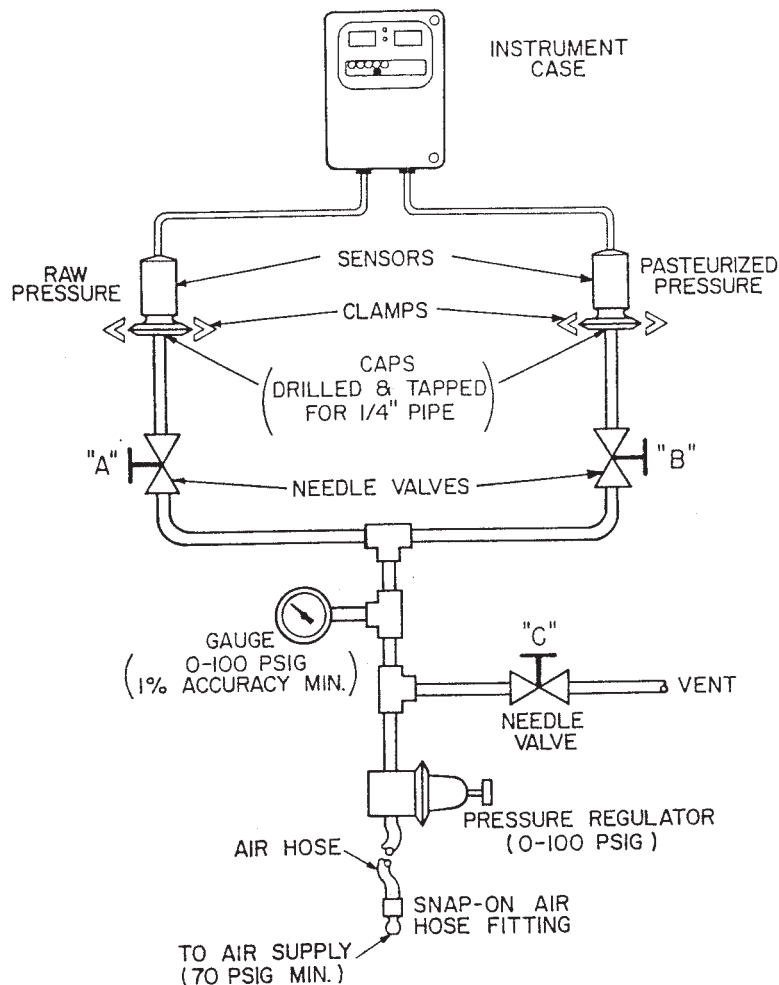

Procedure**A. Checking Pressure Readings at Zero:**

Loosen the process connection at both pressure sensors and allow any fluid to drain through the loose connections. Both the raw and pasteurized digital displays should read zero. To adjust, open the instrument cover and turn the blue potentiometer ("pot") labeled "o" on the side-in circuit board in the lower right corner. There is a board for each input. The "pot" should be adjusted until the digital reads -1 and then turned until it just changes the zero. Both channels should be adjusted identically.

B. Checking Accuracy of Both Channels:

Remove both sensors and mount them on the apparatus. Orient the sensors as they will be installed on the pasteurizer (horizontal or vertical). Increase the pressure on both sensors to a level near the normal pasteurized pressure at the regenerator outlet. Check to see that both digital displays are within 1 psi of the actual pressure. If not, calibration is required. Refer to calibration procedure in this manual.

C. Checking Differential Switch Closure:

Reduce pressure on both sensors to the normal booster pump discharge pressure. Both channels should agree and no bargraph lights should be lit. Depressing the "test high" button in the lower right corner of the display board will close the normally open-to-common contact on K-1. Since there is no power to K-1 until forward flow is achieved, a test light with integral battery can be placed across N.O. and Com. to test relay operation. If no test lamp is available, listening for a "click" upon depressing or releasing the button should indicate proper switch operation.

NOTE: Depressing the "test high" button will *not* cause the green indicator to light, or the bar graph to change.

D. Checking Differential Accuracy:

Isolate the raw sensor and then slowly increase the pressure on the pasteurized sensor. For each 1 psi difference between the two displays, 1 LED on the bar graph should light. Continue increasing the pressure on the pasteurized sensor until the green light comes on.

At this point the bar graph lights should be equal to or 1 psi greater than the set point indicator light. The set point selector should be set at 2 psi differential or greater. If necessary, adjust the differential setting by referring to the Calibration section of this manual.

E. Checking Differential Switch Operation:

With the differential pressure above the set point, depresses the "test low" button on the display board. The differential bargraph should indicate zero differential and the green light should go out. Release the button. Decrease the pressure on the pasteurized sensor until the two displays agree. Relieve pressure on both sensors, remove from the apparatus, and reinstall on the pasteurizer.

4.2 CALIBRATION ADJUSTMENTS

The calibration adjustments are readily accessible on opening the case door. This requires breaking the seal wire attached by the local health inspector.

FIGURE 13 CALIBRATION ADJUSTMENT LOCATIONS

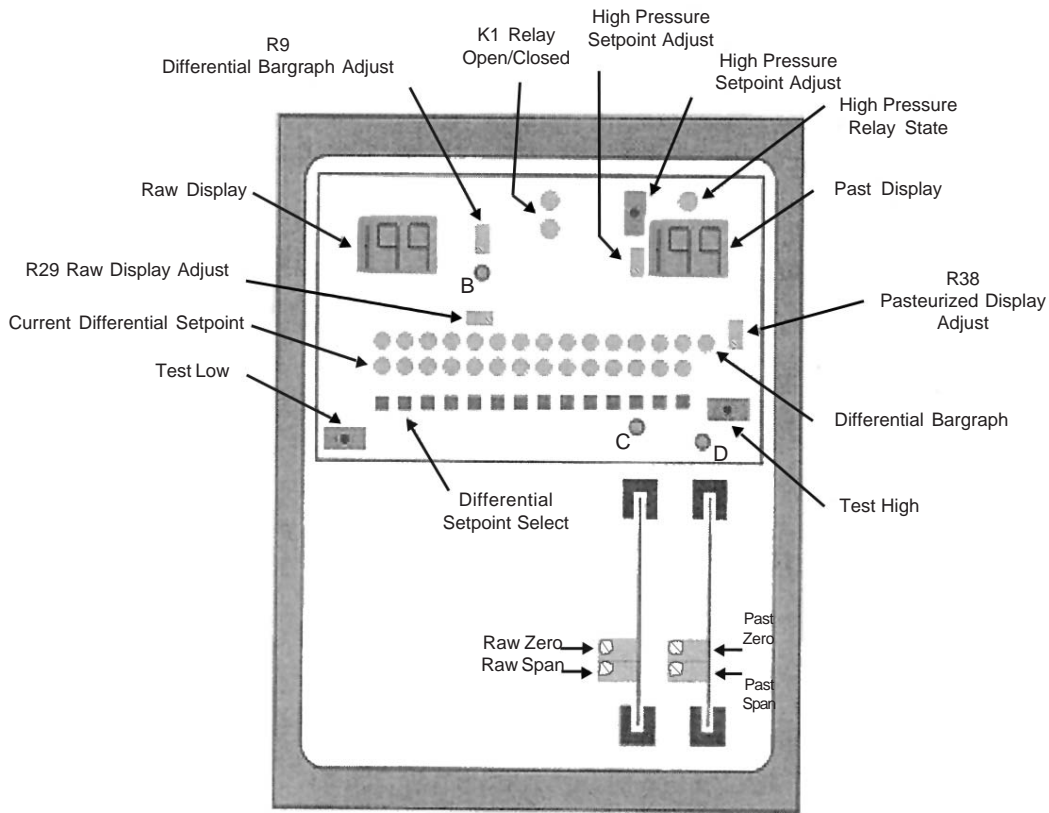

WARNING: Do not remove the signal conditioning boards. They must be fully seated for electrical contact, in their correct orientation (adjustment screws on the left side), and in the proper order (serial numbers corresponding to the order shown on the instrument nameplate inside the door).

4.3 CALIBRATION PROCEDURE

1. Taking care not to dent the sensor diaphragms, remove the sensors from the process and connect to the test fixture.
2. Locate the 0-1 VDC test points B, C & D as shown in Figure 13. Connect the Black (-) meter lead to TP C, and the Red (+) meter to TP B.
3. Open all valves of the test fixture so zero pressure is applied to both sensors. Adjust the "Zero" potentiometer on the RAW (left) side Input Card (Figure 13) to make the meter read 0.00 VDC.
4. Move the Red (+) meter lead to TP D, and adjust the "Zero" potentiometer on the PASTEURIZED (right) side Input Card (Figure 13) to make the meter read 0.00 VDC.
5. Close valve C and adjust the air regulator to obtain an applied air pressure equal to or above the normal operating pressure of the booster pump. Move the Red (+) meter lead to TP B. Adjust the "Span" potentiometer on the RAW (left) side Input Card (Figure 13) to make the meter read the actual pressure, divided by 100 (45 psig = .45 VDC).
6. Move the Red (+) meter lead to TP D. Adjust the "Span" potentiometer on the pasteurized (right) side Input Card (Figure 13) to make the meter read the same VDC as calculated in Step 5.
7. Adjust the "Raw Display Adjust" potentiometer "R29" (Figure 13) for the RAW side display, and the "Pasteurized Display Adjust" potentiometer "R38" (Figure 13) for the pasteurized side display. The displays should be set the same as the current known pressure set on the calibrator.
8. Move the Black (-) meter lead to TP B. Close valve B, and adjust the air regulator so that the air pressure on the RAW channel drops to a point where the difference between the channels is equal to, or slightly above, the desired differential set point (4 psi differential will read 0.040). Adjust the "Differential Bargraph Adjust" potentiometer "R9" to cause the correct number of LED's to illuminate. For example, with a differential voltage of 0.040 VDC, you should see four LED's lit.
9. This completes the calibration. Place the sensors back onto the process, again taking care not to damage the diaphragms.

4.4 CALIBRATION OF 4-20 mA OUTPUTS

NOTE: *These outputs are factory calibrated for a 4-20mA signal over a 0-100 psig or psid range. Outputs proportional to the raw or pasteurized pressure are most easily checked during calibration of the sensors, Section 4.3.*

Output proportional to the differential pressure can be checked during calibration of the differential, 4.3. This output is proportional to a full 0-100 psid, even though only 1-15 psid (or 5-75 psid) is indicated on the bargraph. The output at 15 psid should be 6.4 mA and at 75 psid should be 16mA.

The formula for determining proper output at any known pressure or differential is:

$$\left[\left[\frac{\text{Differential}}{100} \right] \times 16 \right] + 4$$

Zero and Span adjustments for these outputs are located as shown in Figure 9. Zero for the output should be adjusted during the final zero check in Section 4.3 and span during the final span check in 4.3.

NOTE: *If a unit is supplied with outputs on the raw channel and the differential, the raw output will be moved to channel 2 position.*

Outputs may be monitored at the receiver or by placing a mA meter in series at any point in the loop.

WARNING: *These are non-isolated outputs and should not be wired as single ended inputs.*

Section 5 Troubleshooting

5.1 TROUBLESHOOTING

As with any electronic device, all electrical components should be checked first. Refer to figures 5 and 6 for proper AC power and signal input connections. Be sure all plug-in connectors are properly and firmly inserted on the circuit board. If these are found to be proper, continue as follows:

Nothing on Case Lights Up

- Cause: Loose Ribbon cable connection
Action: Open case door, and push down (with finger) the pin connector strip at both ends of the wide ribbon cable connecting the top and bottom circuit boards
- Cause: No electrical power
Action: Check input voltage across terminals 1 and 2 (see Section 2). Figure 6 should correspond with the voltage shown on name plate inside the cover
- Cause: Bad fuse
Action: Remove fuse (see Section 2, Figure 6), and check. Even if no fuse wire break is visible, make an electrical continuity check (breaks and poor connections can be hidden by fuse end caps). Be sure to reinsert fuse firmly.

WARNING: *If fuse blows again, trouble is in electronic circuitry, and instrument must be returned to factory for service.*

Significant Error in Pressure Readings

1. Cause: Loose or improperly inserted interface boards
Caution: *Never remove or reinsert interface boards with power "on". Turn off power or remove fuse.*
Action: Open case door and push interface boards firmly into slide socket (see Figure 13). Check that boards are not inserted backwards, adjustment screws should be on the left side as shown. Check also that interface boards are not interchanged, board serial numbers should correspond with channel 1 and 2 serial numbers listed on nameplate inside the cover.
2. Cause: Loose socketed component on circuit boards
Action: (a) Push down (with finger) the pin connector strip at both ends of the wide ribbon cable connecting the top and bottom circuit boards, (b) also push down (with finger) the two digital displays to be sure they are firmly seated in their sockets.
3. Cause: Loose sensor connector
Action: Check that pressure sensor connectors inside case in upper right corner are firmly inserted
4. Cause: Faulty pressure sensor
Action: If one pressure reading appears significantly in error, while the other pressure reading is correct, reverse the two pressure sensor input connectors. Apply and remove the pressure to the sensors, remembering that raw pressure will be displayed in the pasteurized pressure window, and vice-versa. If pressure readings from the suspect sensor are not correct (allowing for some smaller calibration error since the wrong interface board is used), the problem is elsewhere. If similar faulty readings are obtained, remove the faulty pressure sensor from its process location and carefully examine its diaphragm. Dents and over-ranging will result in an above-zero reading with no pressure applied. For smaller above-zero readings, recalibrating the sensor (see Section 4) may permit it to be continued in service. Otherwise, the faulty sensor should be returned to the factory for repair or replacement. Its corresponding interface board should also be returned if factory calibration is desired.
5. Cause: Faulty interface board
Action: If one pressure reading appears significantly in error, while the other pressure reading is correct, reverse the two interface boards inside the case, with the power off. If similar faulty readings are obtained, the problem is elsewhere, but if pressure readings now appear correct (allowing for some smaller calibration error since the wrong interface board is used), the faulty interface board should be returned to the factory for repair or replacement. Its corresponding pressure sensor should also be returned if factory calibration is desired.

Several voltage (D.C.) checks can be easily made to determine sensor and circuit board functioning. Checks are first made at the input terminal block to check excitation voltage and sensor outputs. These are followed by display board voltage checks to verify interface card functioning and calibration.

1. Input Terminal Blocks:

These are accessed by removing the two right-side display board screws and pivoting the board to the left. The input blocks are located along the upper right edge of the power board. Each should contain a four-wire input with shield (see Figure 8). Excitation voltage is checked across +EX and -EX (red and black) and should read 9.9-10.1 VDC. Input voltage is checked across +IN and -IN and should read between -3.0 mV and +3.0 mV at zero pressure. The input span is 50 mV over the 0-100 psig range (eg. A normal input range might run -1.0mV to +49mV). Sensors with outputs outside these limits should be replaced.

Three voltage regulators are accessible on this board as well. Proper voltage for these are labeled on Figure 13. Test loops located at center of board.

2. Display Board:

The JD display board contains three test points labeled B, C, and D. (see Figure 13). The voltage for the raw (left) channel is checked across B and C, with the negative lead on C. This voltage range is 0-1 VDC over the 0-100 psig input range. The voltage for the pasteurized (right) channel is checked across D and C, with C being negative. Again the voltage range is 0-1VDC. Zero and span adjustments for these voltages are located on the corresponding plug-in interface cards. Scale adjustments for the displays are made on R-29 (Raw) and R-38 (Past). For any differential pressure, the corresponding differential voltage can be calculated and checked across B and D. This voltage is adjusted using potentiometer R-9 to the right of the Raw display. With this voltage set properly, the bar graph accurately displays the differential.

Appendix A

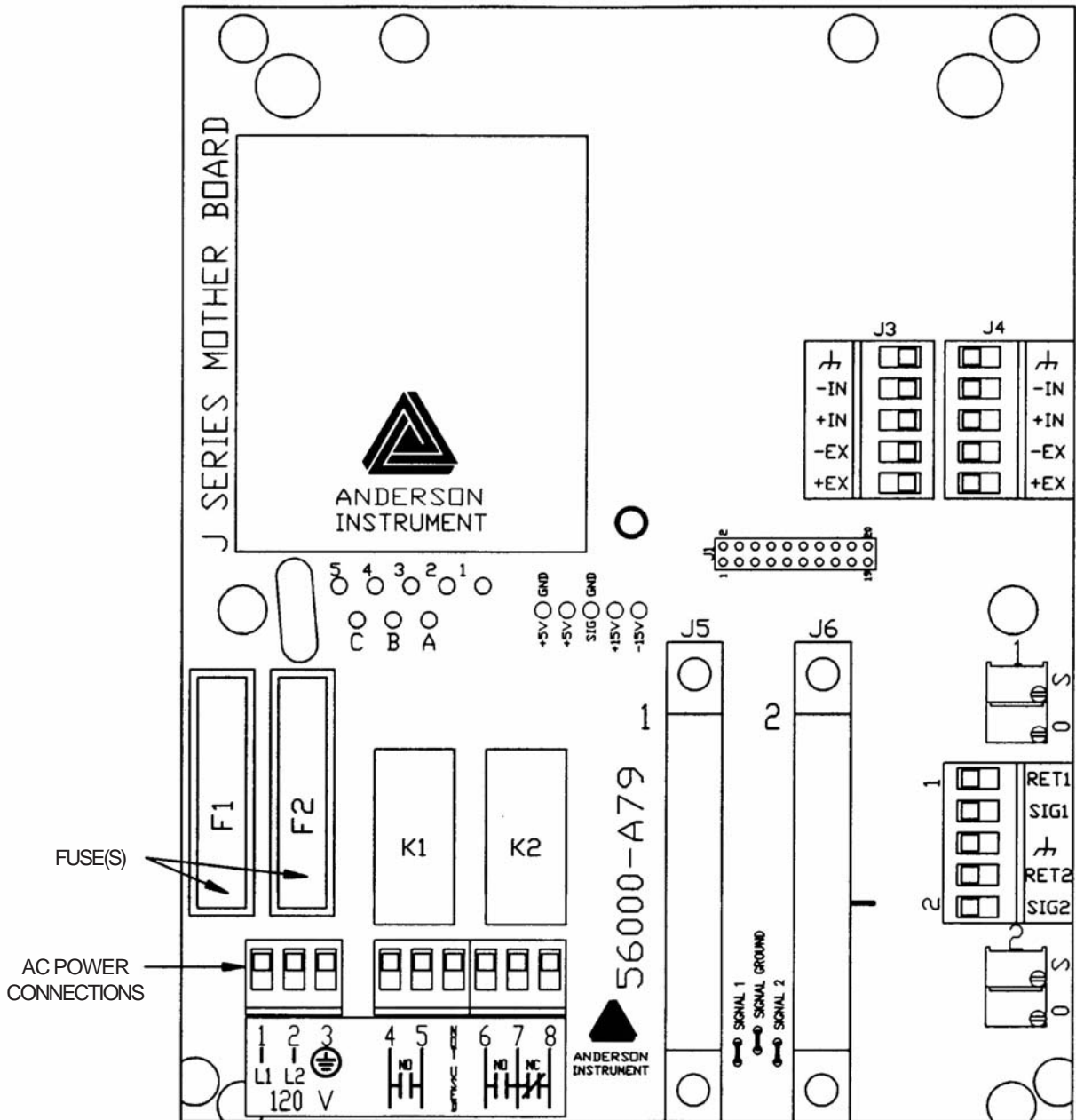

Appendix B

MASTER PARTS LIST

Unit	Part Number	Part Description
JD (Man)	56014E0098	1-15 PSID Display Board
JD (Man)	56014E0097	Powerboard / 120VAC
JD (Man)	SY070G0051100	Transducer / 2"TC / 0-99 / with Card
JD (Man)	SY070G0041100	Transducer / 1.5"TC / 0-99 / with Card
JD (Man)	56014E0084	50 mV Input Card
JD	56014E0104	Powerboard / 240 VAC
JD	SY070G0161100	Transducer / Cherry "I" / 1.5" / 0-99 / Card
JD	SY070G0171100	Transducer / Cherry "I" / 2" / 0-99 / Card
JD	SY070G0451100	Transducer/ 2" #14 Bev. Seat / Nut / Card
JD	56014E0106	5-75 PSID Display Board
JD	56014E0087	Transmitter Input Board - External Power
JD	56014E0088	Transmitter Input Board - Internal Power
JD	56014E0107	0.1-1.5 Kg/cm

Appendix C

Warranty and Return Statement

These products are sold by The Anderson Instrument Company (Anderson) under the warranties set forth in the following paragraphs. Such warranties are extended only with respect to a purchase of these products, as new merchandise, directly from Anderson or from an Anderson distributor, representative or reseller, and are extended only to the first buyer thereof who purchases them other than for the purpose of resale.

Warranty

These products are warranted to be free from functional defects in materials and workmanship at the time the products leave the Anderson factory and to conform at that time to the specifications set forth in the relevant Anderson instruction manual or manuals, sheet or sheets, for such products for a period of one year.

THERE ARE NO EXPRESSED OR IMPLIED WARRANTIES WHICH EXTEND BEYOND THE WARRANTIES HEREIN AND ABOVE SET FORTH. ANDERSON MAKES NO WARRANTY OF MERCHANTABILITY OR FITNESS FOR A PARTICULAR PURPOSE WITH RESPECT TO THE PRODUCTS.

Limitations

Anderson shall not be liable for any incidental damages, consequential damages, special damages, or any other damages, costs or expenses excepting only the cost or expense of repair or replacement as described above.

Products must be installed and maintained in accordance with Anderson instructions. Users are responsible for the suitability of the products to their application. There is no warranty against damage resulting from corrosion, misapplication, improper specifications or other operating condition beyond our control. Claims against carriers for damage in transit must be filed by the buyer.

This warranty is void if the purchaser uses non-factory approved replacement parts and supplies or if the purchaser attempts to repair the product themselves or through a third party without Anderson authorization.

Returns

Anderson's sole and exclusive obligation and buyer's sole and exclusive remedy under the above warranty is limited to repairing or replacing (at Anderson's option), free of charge, the products which are reported in writing to Anderson at its main office indicated below.

Anderson is to be advised of return requests during normal business hours and such returns are to include a statement of the observed deficiency. The buyer shall prepay shipping charges for products returned and Anderson or its representative shall pay for the return of the products to the buyer.

Approved returns should be sent to: ANDERSON INSTRUMENT COMPANY INC.
156 AURIESVILLE ROAD
FULTONVILLE, NY 12072 USA

ATT: REPAIR DEPARTMENT