

---

# Instruction Manual

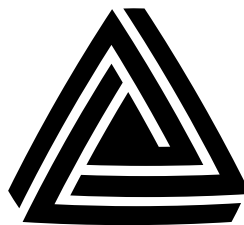

Anderson Instrument Co. Inc.  
156 Auriesville Road  
Fultonville, NY 12072  
1-800-833-0081  
Fax 518-922-8997

**ANDERSON-NEGELE**

Instrument Model Number \_\_\_\_\_

Instrument Serial Number \_\_\_\_\_

## **DTG for Retorts**

## **Style FH3 or FH4**

# ATTENTION

## MODEL FH3 AND FH4

### “DTG” Digital Temperature Gauge for Retort Applications

This product contains specialized “AA” size Thionyl Chloride Lithium batteries. Specifications are as follows:

- Nominal Capacity = 2.4 Ah
- Operating Voltage = 3.6 VDC
- Maximum Operating Temperature = 185 degrees F
- Manufacturer = Xeno
- Model = XL060F

Please be aware that the operating voltage of a typical “AA” Alkaline cell is 1.5 VDC.

Thionyl Chloride Lithium 3.6VDC “AA” cells REQUIRED for operation. If standard Alkaline 1.5VDC cells installed, following message displayed:

USE 3.6 LITH BATT

DO NOT remove these cells and place into other equipment. The higher operating voltage may cause damage to that device. The Anderson DTG models FH3 and FH4 are designed to operate at this higher voltage.

For applications where the DTG comes in close contact with the retort outer shell, such as “well” or “port” mounting, Anderson recommends the use of this cell.

Copies of the MSDS may be obtained directly from Anderson Instrument Company Technical or Customer Service.

Replacement cells may be ordered through your local Distributor, or by contacting Anderson Instrument Company directly for additional information.

Part #: 62071A0001

Customer Service: 800-833-0081

**Note: When removing batteries, wait a minimum of (2) two minutes before re-installing.**

---

## Table of Contents

	<b>Page</b>
<b>Section 1 - General</b>	<b>4</b>
1.1 Description	4
<b>Section 2 - Specifications</b>	<b>5</b>
<b>Section 3 - Installation</b>	<b>6</b>
3.1 Overview	6
<b>Section 4 - Tamper Proof Seal</b>	<b>7</b>
<b>Section 5 - User Calibration Adjustments</b>	<b>8</b>
5.1 Change Offset Value	8
5.2 Change Unit of Measure	9
5.3 Change Dampening Factor	10
5.4 Change Decimal Position	11
5.5 User Calibration	12
5.6 User Calibration - Error Condition	18
5.7 Reset Any Point	18
5.8 Restore Factory Settings	19
<b>Section 6 - Service</b>	<b>21</b>
6.1 Battery Replacement	21
6.2 Self Check - Error Condition	22
<b>Appendix A - Warranty and Return</b>	<b>23</b>

---

## **Section 1 General**

---

### **1.1 DESCRIPTION**

The Anderson DTG Digital Temperature Gauge is a fully electronic, battery powered device designed as an "Alternate Temperature Indicating Device" for use in Retorts. This device features a dual element design that provides continuous error checking of the temperature signals. Units are shipped from the factory with a certificate of calibration against an NIST traceable source. For on-site calibration, from two to five user scaling points are available to match an in-house customer supplied reference standard.

With the above features, this unit meets all requirements as outlined in the Code of Federal Regulations (CFR) covering the processing of low acid canned foods.

The simple to read LCD display incorporates a "low battery" indicator to signal the need for replacement of the batteries.

Dual temperature elements feed a continuous comparator circuit. A visual warning is provided via the LCD display for any deviation beyond .5 deg F from the primary to the secondary element. In this condition, both the primary and secondary element readings are shown on the display, and may be compared to a secondary device such as the recording thermometer installed in the process. This allows the process to run without the need for an emergency shutdown as in the case of a broken mercury thermometer.

---

## Section 2 Specifications

Compliance:	CE, 3-A, NEMA 4X, IP-66
Product Contact Surface:	Fitting & Probe: 316L SS
Non-Product Contact Surface:	Housing - 304 SS Lens - Polysulfone
Process Temp. Range:	0 to 300°F (-18 to 150°C)
Units:	Deg F and Deg C; field selectable
Resolution:	0.1°F or °C
Accuracy:	+/- .5°F (+/-0.3°C)
Ambient Operating Limits:	40 to 158°F (4.4 to 70°C) (With use of Thionyl Chloride Lithium battery only)
Ambient Temp. Stability:	Better than 0.1°C per 10°C ambient shift
Storage Temp.:	32 to 140°F (0 to 65°C)
Display:	LCD: 4 digit main display, 6 digit secondary; 0.9" high contrast LCD
Error Warning:	LCD flashing
Power:	Field replaceable battery; Thionyl Chloride Lithium 3.6VDC; AA package
Battery Life:	18 months typical (With use of Thionyl Chloride Lithium battery only)
Vibration:	10 to 60 Hz, 2g
Warranty:	2 year
Display Update:	3 seconds
Calibration Adjustment:	Via onboard switches; up to five field adjustable points
Surface Finish:	R <sub>a</sub> max = 32 micro inches

## Section 3 Installation

### 3.1 OVERVIEW

The DTG has been shipped fully calibrated and ready to place into service.

NOTE: If your facility has an in-house calibration program, refer to the calibration section of this document for details on the "User Calibration" procedure.

Example shown  
Back Mount

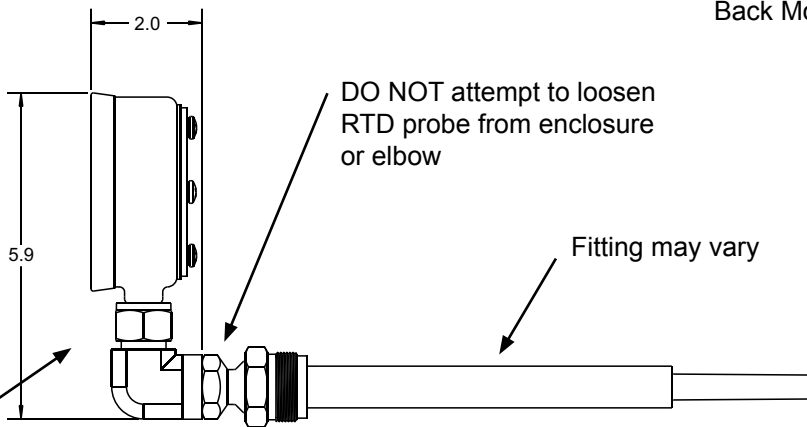

**CAUTION: If unit is supplied with an *elbow* fitting, it may be loosened slightly to allow adjustment of the angle. However, DO NOT twist more than 180° or wire damage may occur.**

Example shown  
Remote Mount

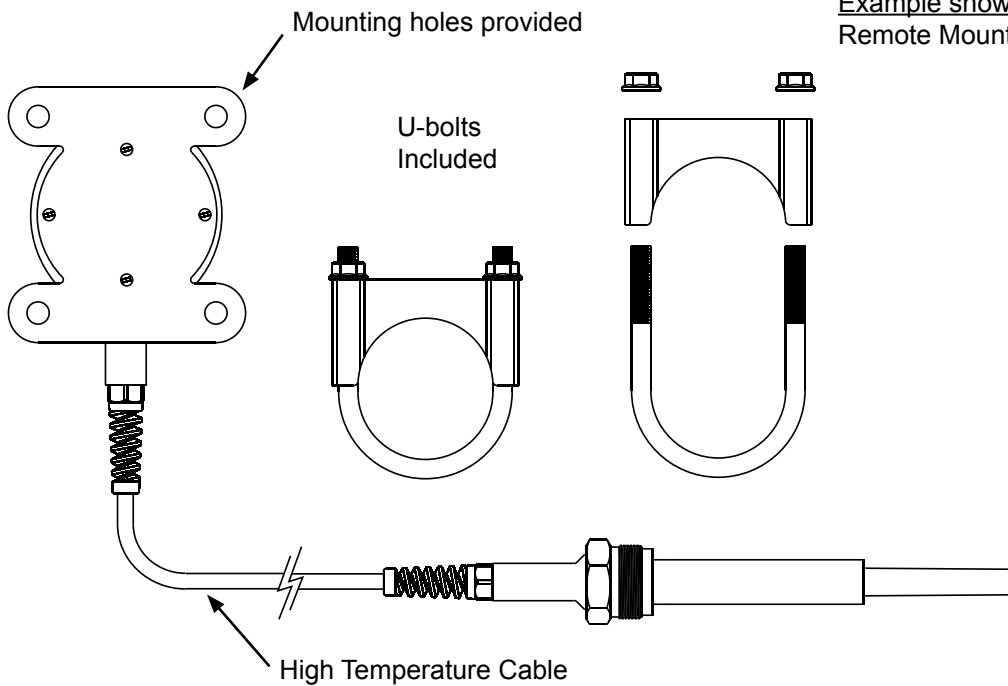

---

## Section 4 Tamper Proof Seal

The DTG has been supplied with “Tamper Evident” sealing capability. As shown in the following diagram, the screws that hold the back plate in place have a small through hole ready to accept a wire seal.

Upon calibration of the unit, the Technician may place a wire through the two through holes, and secure with a tamper proof seal.

Example: Brooks Seals or equivalent

[www.brookseals.com](http://www.brookseals.com)

“Roto Seal” or “Toolless Roto Seal”

Seals such as the example above may be ordered with serialized identifiers. This will allow recording of the calibration details with a unique reference. Anderson does not supply these products. Information above supplied for reference only.

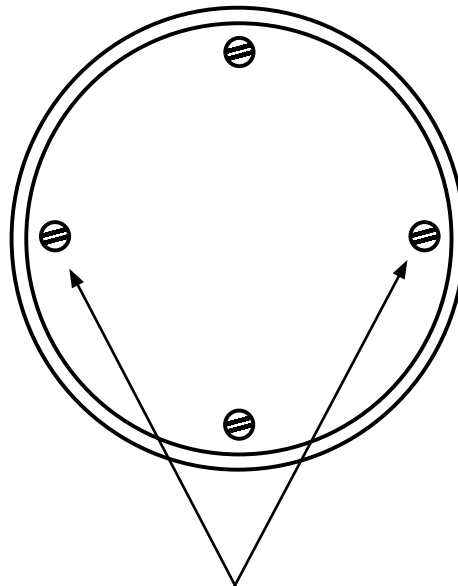

Secure wire seal through both screws to prevent removal of the backplate.

## Section 5 User Calibration Adjustments

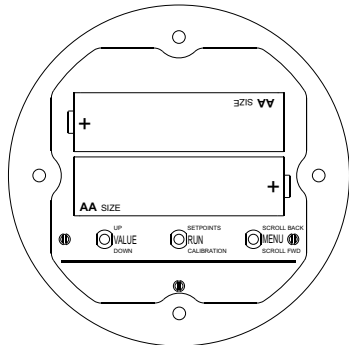

**NOTE:** Remove back plate to access Value, Run, and Menu keys used for programming.

### 5.1 CHANGE OFFSET VALUE

The “Offset Value” function is used to apply a linear offset factor to the device. If your DTG shows a repeatable discrepancy (less than 1 degree) throughout the test range, this function may be used to remove the differential.

Example: Reference reads 32.0°F and DTG reads 32.3°F  
 Reference reads 150.0°F and DTG reads 150.3°F  
 Reference reads 212.0°F and DTG reads 212.3°F

“Offset Value” of “-0.3°F” programmed will remove discrepancy

**CAUTION:** Be sure to use only an NIST traceable reference thermometer that is known accurate, and within it’s specified calibration period.

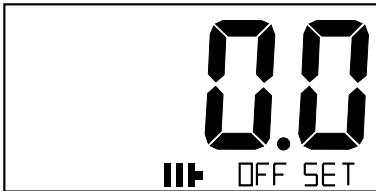
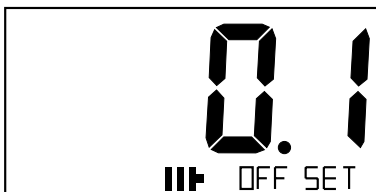
1.	Flip <b>Run</b> switch to the down position.	
2.	Press <b>Menu</b> switch up and release once to go to <i>Offset</i> screen.	
3.	Use <b>Value</b> switch to set <i>Offset</i> from 0.0 to +/-5.0.	
4.	Flip <b>Run</b> switch to the middle position.	



**5.2 CHANGE UNIT OF MEASURE**

The DTG may be programmed to read in either Degrees F or Degrees C. When changing from one mode to another, any "User Calibration" points are converted automatically to their respective unit of measure – no additional programming is required.

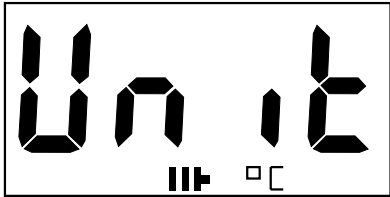
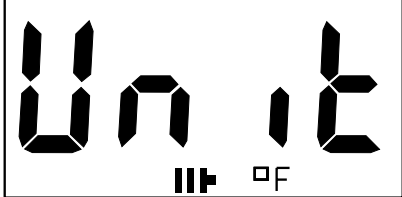
<p>1. Flip <b>Run</b> switch to the down position.</p>	
<p>2. Press <b>Menu</b> switch down and release once to go to <i>Unit</i> screen.</p>	
<p>3. Use <b>Value</b> switch to alternate between °F and °C.</p>	
<p>4. Flip <b>Run</b> switch to the middle position.</p>	

**5.3 CHANGE DAMPENING FACTOR**

The “Dampening Factor” is used as a means to slow down the reaction rate of the unit. Under most circumstances, this value should be set to “0.” If a process has very erratic temperature shifts, and the display fluctuates, introduction of a small dampening factor may smooth display.

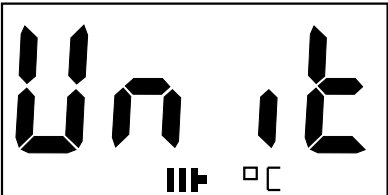
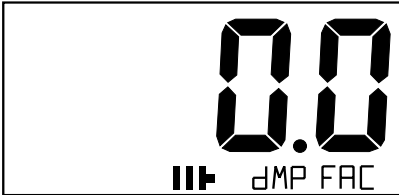
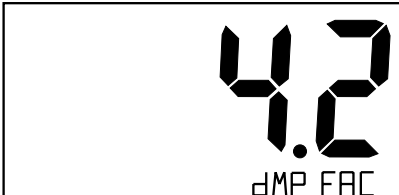

<p>1. Flip <b>Run</b> switch to the down position.</p>	
<p>2. Press <b>Menu</b> switch down and release once to go to <i>Unit</i> screen.</p>	
<p>3. Press <b>Menu</b> switch down and release once to go to <i>Dampening Factor</i> screen.</p>	
<p>4. Use <b>Value</b> switch to set <i>Dampening Factor</i> from 0.0 to 10.0.</p>	
<p>5. Flip <b>Run</b> switch to middle position.</p>	

**5.4 CHANGE DECIMAL POSITION**

The DTG is capable of displaying to the nearest WHOLE DEGREE, or with the addition of a decimal point, to the NEAREST TENTH degree. Modifying this parameter requires no additional programming changes to “User Calibration” points.

Note: When reading in WHOLE DEGREES, the display will ROUND DOWN to the previous whole number.

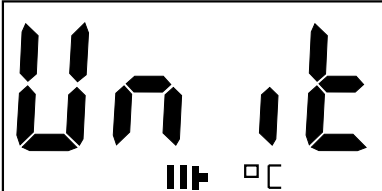
Example: Unit programmed to display tenths  
 Actual process temperature **190.7 degree F**  
 DTG display shows **190.7 degree F**  
 Unit programmed to display WHOLE NUMBERS  
 Actual process temperature **190.7 degree F**  
 DTG display shows **190 degree F**

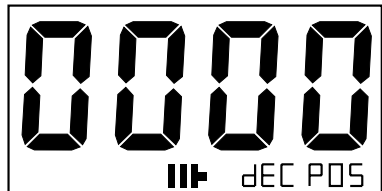

<p>1. Flip <b>Run</b> switch to the down position.</p>	
<p>2. Press <b>Menu</b> switch down and release once to go to <i>Unit</i> screen.</p>	
<p>3. Press <b>Menu</b> switch down and release once to go to <i>Dampening Factor</i> screen.</p>	
<p>4. Press <b>Menu</b> switch down and release once to go to <i>Decimal Position</i> screen.</p>	
<p>5. Use <b>Value</b> switch to alternate select decimal position.</p>	
<p>6. Flip <b>Run</b> switch to middle position.</p>	



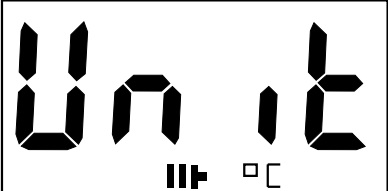
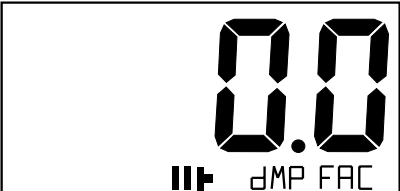
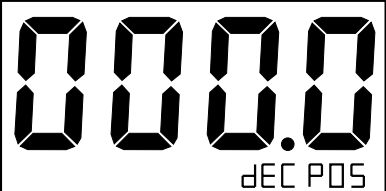

**5.5 USER CALIBRATION**

The DTG is provided from the Factory fully calibrated and traceable to an NIST reference. If the user chooses, from TWO to FIVE custom calibration points may be activated. This function allows adjustments to be made at specific points that match the process, or to remove slight discrepancies between factory and field reference standards.

CAUTION: Prior to performing “User Calibration” point entries, be sure to RESET the “Offset Value” to “0” if any entry has been made.

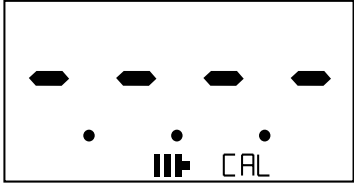
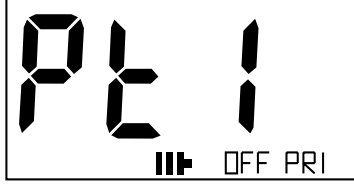
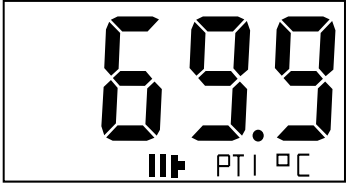

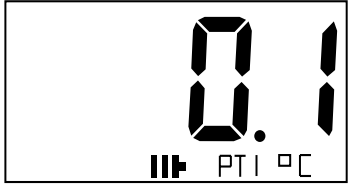
NOTE: If the “User Calibration” mode is implemented, a minimum of TWO points must be entered. Entering only a single point will result in an “Err” error condition.

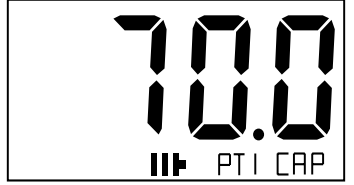
1.	Flip <b>Run</b> switch to the down position.	
2.	Press <b>Menu</b> switch down and release once to go to <i>Unit</i> screen.	
3.	Press <b>Menu</b> switch down and release once to go to <i>Dampening Factor</i> screen.	
4.	Press <b>Menu</b> switch down and release once to go to <i>Decimal Position</i> screen.	
5.	Press <b>Menu</b> switch down and release once to go to <i>User Cal</i> screen.	

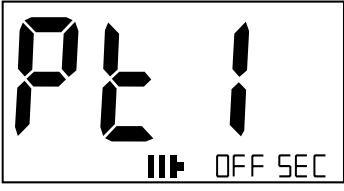
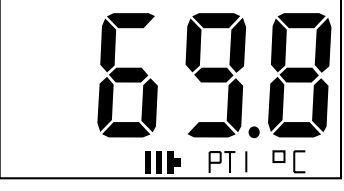
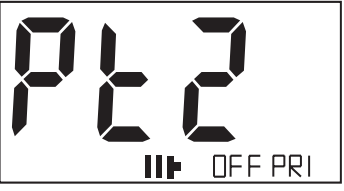
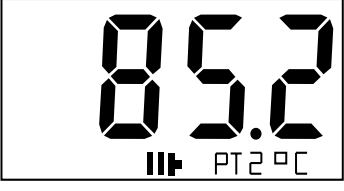
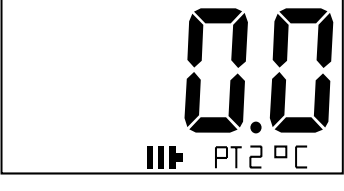
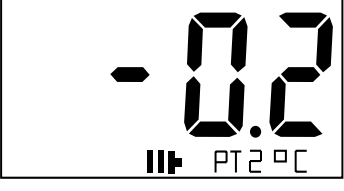

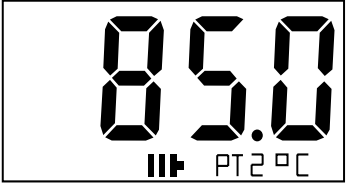
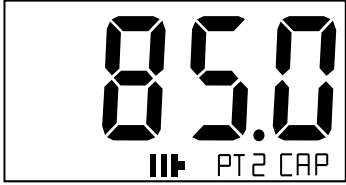
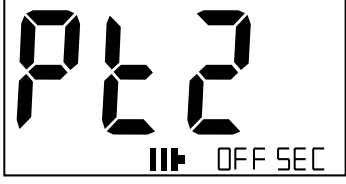
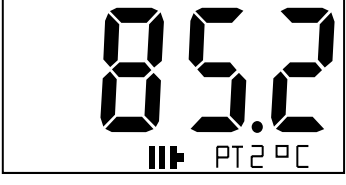
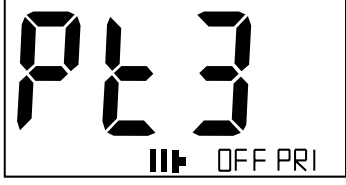

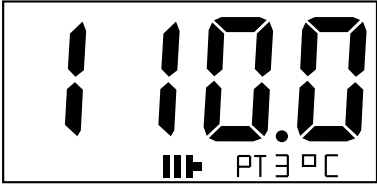
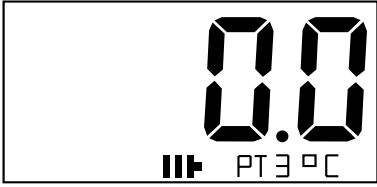
6.	Press <b>Value</b> scroll switch up for 5 seconds to enter <i>User Calibration Run</i> .	 <p>The screen shows four horizontal dashes at the top, a battery level indicator (three vertical bars) in the center, and the text 'CAL' on the right.</p>
7.	Place unit in temperature controlled bath.	
8.	Press <b>Menu</b> switch down and release to go to <i>Point 1 Primary</i> .	 <p>The screen displays 'Pt 1' in large digits, a battery level indicator (three vertical bars) below it, and 'OFF PRI' at the bottom right.</p>
9.	After allowing the unit to stabilize in the bath for at least 7 minutes hold <b>Value</b> switch up for 5 seconds to enter <i>Point 1 Temperature</i> screen. The screen will display the captured temperature.	 <p>The screen displays '69.9' in large digits, a battery level indicator (three vertical bars) below it, and 'PT1 °C' at the bottom right.</p>
10.	Press <b>Menu</b> switch down and release to go to <i>Point 1 Offset</i> . (In this example, the bath is at 70.0°C so the temperature on the display needs to be adjusted by 0.1)	 <p>The screen displays '0.0' in large digits, a battery level indicator (three vertical bars) below it, and 'PT1 °C' at the bottom right.</p>
11.	Use <b>Value</b> switch to adjust the offset to so that the DTG temperature will match the temperature of the bath.	 <p>The screen displays '0.1' in large digits, a battery level indicator (three vertical bars) below it, and 'PT1 °C' at the bottom right.</p>
12.	Once the value for the offset has been input, press <b>Menu</b> switch down and release to go to <i>Point 1 Exit</i> . If the offset entered is correct, the screen should display the same temperature as the bath that it is in. (In this case 70.0°C)	 <p>The screen displays '70.0' in large digits, a battery level indicator (three vertical bars) below it, and 'PT1 °C' at the bottom right.</p>
13.	Hold <b>Value</b> switch up for 5 seconds to save <i>Point 1 Offset</i> .	 <p>The screen displays '70.0' in large digits, a battery level indicator (three vertical bars) below it, and 'PT1 CAP' at the bottom right.</p>

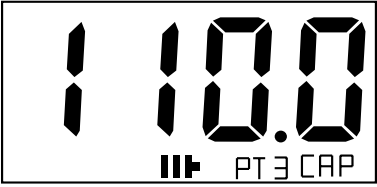
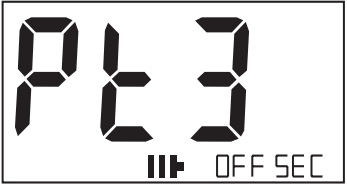
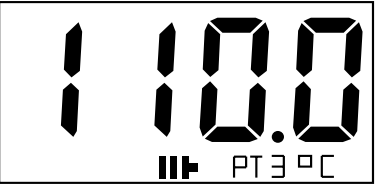
14.	Press <b>Menu</b> switch down and release to go to <i>Point 1 Secondary</i> (if the unit does not have a secondary element, pressing <b>Menu</b> switch down will take the user to <i>Point 2</i> ).	
15.	Hold <b>Value</b> switch up for 5 seconds to enter <i>Point 1 Temperature</i> screen.	
16.	Follow steps 9 - 13. The unit has already stabilized so there is no need to wait an additional 7 minutes.	
17.	Remove unit from first temperature controlled bath and place in second temperature controlled bath.	
18.	Press <b>Menu</b> switch down and release to go to <i>Point 2 Primary</i> .	
19.	After allowing the unit to stabilize in the bath for at least 7 minutes hold <b>Value</b> switch up for 5 seconds to enter <i>Point 2 Temperature</i> screen. The screen will display the captured temperature.	
20.	Press <b>Menu</b> switch down and release to go to <i>Point 2 Offset</i> (In this example, the bath is at 85°C so the temperature on the display needs to be adjusted by -0.2)	
21.	Use <b>Value</b> switch to adjust the offset to so that the DTG temperature will match the temperature of the bath.	

22.	Once the value for the offset has been input, press <b>Menu</b> switch down and release to go to <i>Point 2 Exit</i> . If the offset entered is correct, the screen should display the same temperature as the bath that it is in. (In this case 85°C)	
23.	Hold <b>Value</b> switch up for 5 seconds to save <i>Point 2 Offset</i> .	
24.	Press <b>Menu</b> switch down and release to go to <i>Point 2 Secondary</i>	
25.	Hold <b>Value</b> switch up for 5 seconds to enter <i>Point 2 Temperature</i> screen.	
26.	Follow steps 19 - 23.	
27.	Remove unit from second temperature controlled bath and place in third temperature controlled bath.	
28.	Press <b>Menu</b> switch down and release to go to <i>Point 3 Primary</i> .	

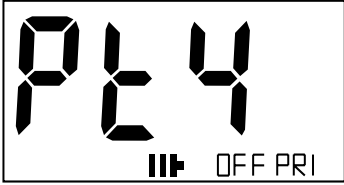
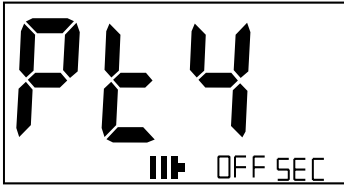
29.	<p>After allowing the unit to stabilize in the bath for at least 7 minutes hold <b>Value</b> switch up for 5 seconds to enter <i>Point 3 Temperature</i> screen. The screen will display the captured temperature. (The screen shots here are for example only. End user bath temperatures will vary.)</p>	
30.	<p>Press <b>Menu</b> switch down and release to go to <i>Point 3 Offset</i>. (In this example, the bath is at 110°C so the temperature on the display does not need to be adjusted)</p>	
31.	<p>If there is no need to adjust the value of the offset, press <b>Menu</b> switch down and release to go to <i>Point 3 Exit</i>. The screen should display the same temperature as the bath that it is in. (In this case 110°C)</p>	
32.	<p>Hold <b>Value</b> switch up for 5 seconds to save <i>Point 3 Offset</i>.</p>	
33.	<p>Press <b>Menu</b> switch down and release to go to <i>Point 3 Secondary</i>.</p>	
34.	<p>Hold <b>Value</b> switch up for 5 seconds to enter <i>Point 1 Temperature</i> screen.</p>	
35.	<p>Follow steps 29 - 32.</p>	

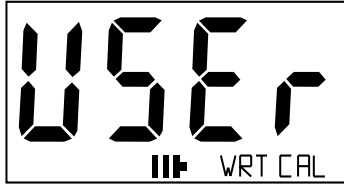

<p><b>NOTE: The above sequencing details the three possible scenarios that could be encountered during the user calibration. Any of these situations could occur at any of the 5 points that the user may or may not use during calibration.</b></p>		
36.	Remove unit from third temperature controlled bath and place in fourth temperature controlled bath. If the user does not require additional calibration points, press <b>Menu</b> switch down and release to go to <i>Point 4 Primary</i> .	
37.	Press <b>Menu</b> switch down and release to go to <i>Point 4 Secondary</i> .	
38.	Press <b>Menu</b> switch down and release to go to <i>Point 5 Primary</i> .	
39.	Press <b>Menu</b> switch down and release to go to <i>Point 5 Secondary</i> .	
40.	Press <b>Menu</b> switch down and release to go to <i>Save Calibration</i> screen.	
41.	Hold the <b>Value</b> switch up for 5 seconds to capture the calibration information.	

5.6 USER CALIBRATION - ERROR CONDITION

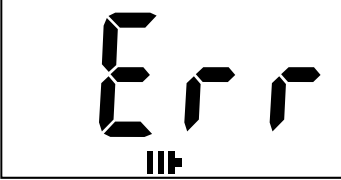

EXAMPLE: Error Condition (see NOTE Page 12)

<p>Hold the <b>Value</b> switch up for 5 seconds to capture the calibration information.</p>	
<p>This shows the user the calibration is not being implemented. The values for <i>Point 1</i> are saved, but they are not used. The user needs to return to the <i>End User Calibration</i> and add at least one additional calibration point and then save the calibration.</p>	

5.7 RESET ANY POINT

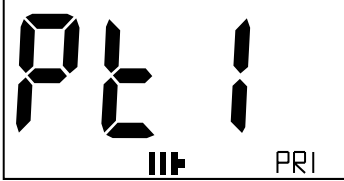

The “Reset Any Point” function will allow a “User Calibration” point to be disabled. Keep in mind that a minimum of TWO “User Calibration” points must be utilized, so an “Err” condition may be activated if only two points were in place and one is deleted.

If multiple “User Calibration” points have been implemented, and one of those points is deactivated, no additional programming is required. The DTG will properly reference the new “User Calibration” point sequence.

1.	Follow steps 1 through 6 from the above procedure.	
2.	Press <b>Menu</b> switch down and release to go to <i>Point 1</i> .	
3.	Hold <b>Value</b> and then <b>Menu</b> up for 5 seconds to reset <i>Point 1</i> .	
4.	Follow the necessary steps of steps 13 through 41 to complete the User Calibration.	
<p><b>NOTE: If a point for the Primary RTD is turned off, the corresponding point for the Secondary RTD must be turned off. Also, if a point for the Secondary RTD is turned off, the corresponding point for the Primary RTD must be turned off.</b></p>		

**5.8 RESTORE FACTORY SETTINGS**

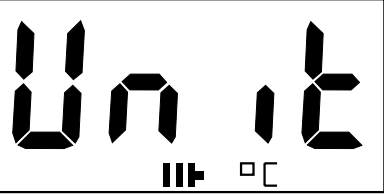
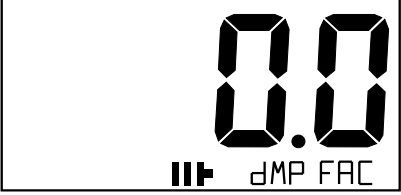
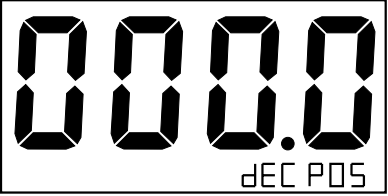
The “Restore Factory Settings” function will deactivate all “User Calibration” points, and return the DTG to the factory shipped calibration.

1.	Flip <b>Run</b> switch to the down position.	
2.	Press <b>Menu</b> switch down and release once to go to <i>Unit</i> screen.	
3.	Press <b>Menu</b> switch down and release once to go to <i>Dampening Factor</i> screen.	
4.	Press <b>Menu</b> switch down and release once to go to <i>Decimal Position</i> screen.	
5.	Press <b>Menu</b> switch down and release once to go to <i>User Cal</i> screen.	
6.	Press <b>Menu</b> switch down and release once to go to <i>Factory Reset</i> screen.	

7.	Hold <b>Value</b> switch up for 5 seconds to restore factory settings.	 A digital display showing the characters 'PFAL' in a large, blocky font. Below the characters, there is a battery icon consisting of three vertical bars of decreasing height from left to right, followed by the text 'VAL RST'.
8.	Flip <b>Run</b> switch to middle position.	

## Section 6 Service

### 6.1 BATTERY REPLACEMENT

The DTG is supplied with two thionyl chloride lithium batteries pre-installed. Under typical usage, six to twelve months of operation can be realized.

**CAUTION**

The supplied batteries have a voltage output greater than a typical alkaline – DO NOT place the supplied batteries into any other device other than a DTG.

Standard alkaline batteries may be used, but typically have a shorter life and may be affected by high temperature; battery leakage may occur.

Replacement TCL batteries may be ordered directly from Anderson.  
Part #: 62071A0001

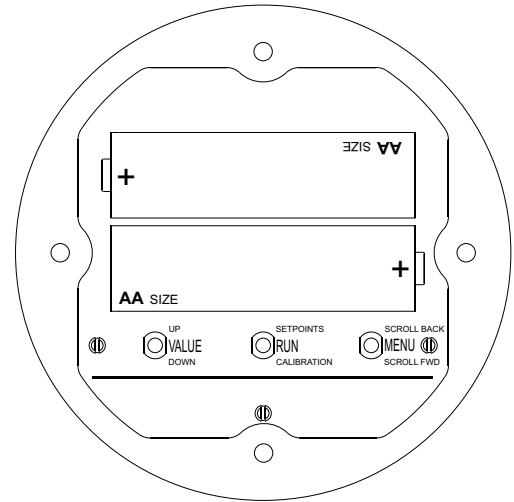

A three segment battery indicator allows the operator to monitor battery life of the DTG, and plan ahead for a battery change. When a low threshold is reached, the final indicator bar blinks on and off. Internal circuitry regulates battery voltages to ensure all factory specifications are met, even with a decrease in battery voltage. When an unacceptable level is reached, the DTG will shut down. Internal flash memory retains all prior calibration, and only replacement of the batteries is required to resume operation.

Full Battery		
Decreased Battery		
Low Battery (blinks between first and second)		

**Note: When removing batteries, wait a minimum of (2) two minutes before re-installing.**

**6.2 SELF CHECK - ERROR CONDITION**

The Digital Temperature Gauge features continuous error checking between the Primary and Secondary temperature elements. In the event of a discrepancy greater than 0.5 degree F, the unit will display an error condition. As illustrated below, the display will alternate between the current primary element temperature, an error warning message and the secondary element temperature.

By recording the temperature shown for the primary and secondary elements, a comparison against the RECORDING THERMOMETER may be performed. This action will allow you to determine which element (Primary or Secondary) has shifted beyond allowable tolerance.

NOTE: If the display has been programmed to indicate WHOLE NUMBERS, the unit will automatically shift to tenths display while in error condition.

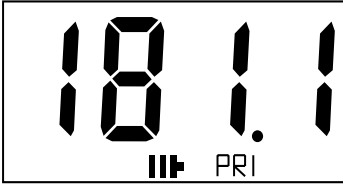
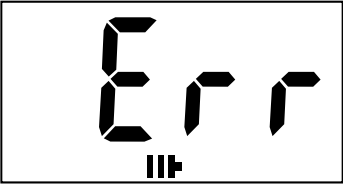
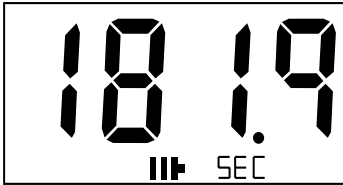
Temperature for Primary element shown	
Error condition displayed	
Temperature for Secondary element shown	

---

## Appendix A

### Warranty and Return Statement

These products are sold by The Anderson Instrument Company (Anderson) under the warranties set forth in the following paragraphs. Such warranties are extended only with respect to a purchase of these products, as new merchandise, directly from Anderson or from an Anderson distributor, representative or reseller, and are extended only to the first buyer thereof who purchases them other than for the purpose of resale.

#### Warranty

These products are warranted to be free from functional defects in materials and workmanship at the time the products leave the Anderson factory and to conform at that time to the specifications set forth in the relevant Anderson instruction manual or manuals, sheet or sheets, for such products for a period of two years.

**THERE ARE NO EXPRESSED OR IMPLIED WARRANTIES WHICH EXTEND BEYOND THE WARRANTIES HEREIN AND ABOVE SET FORTH. ANDERSON MAKES NO WARRANTY OF MERCHANTABILITY OR FITNESS FOR A PARTICULAR PURPOSE WITH RESPECT TO THE PRODUCTS.**

#### Limitations

Anderson shall not be liable for any incidental damages, consequential damages, special damages, or any other damages, costs or expenses excepting only the cost or expense of repair or replacement as described above.

Products must be installed and maintained in accordance with Anderson instructions. Users are responsible for the suitability of the products to their application. There is no warranty against damage resulting from corrosion, misapplication, improper specifications or other operating condition beyond our control. Claims against carriers for damage in transit must be filed by the buyer.

This warranty is void if the purchaser uses non-factory approved replacement parts and supplies or if the purchaser attempts to repair the product themselves or through a third party without Anderson authorization.

#### Returns

Anderson's sole and exclusive obligation and buyer's sole and exclusive remedy under the above warranty is limited to repairing or replacing (at Anderson's option), free of charge, the products which are reported in writing to Anderson at its main office indicated below.

Anderson is to be advised of return requests during normal business hours and such returns are to include a statement of the observed deficiency. The buyer shall pre-pay shipping charges for products returned and Anderson or its representative shall pay for the return of the products to the buyer.

Approved returns should be sent to:                   ANDERSON INSTRUMENT COMPANY INC.  
156 AURIESVILLE ROAD  
FULTONVILLE, NY 12072 USA

ATT: REPAIR DEPARTMENT

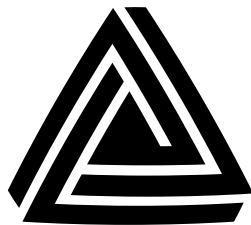

## **ANDERSON-NEGELE**

ANDERSON INSTRUMENT CO., INC • 156 AURIESVILLE RD. • FULTONVILLE, NY 12072 • USA • 800-833-0081 • FAX 518-922-8997  
ANDERSON INSTRUMENT CO. LP • 400 BRITANNIA RD. EAST, UNIT 1 • MISSISSAUGA, ONTARIO L4Z 1X9 • CANADA • 905-568-1440 • FAX 905-568-1652  
NEGELE MESSTECHNIK GmbH (A Division of Anderson) • RAIFFEISENWEG 7 • D-87743 EGG A. D. GÜNZ • GERMANY • +49 (0) 8333/9204-0 • FAX +49 (0) 8333/9204-49

[www.anderson-negele.com](http://www.anderson-negele.com)