

Measurement Point Selector

dmu

General Function

The measurement point selector **dmu** is suitable for selecting up to 10 different measurement points indicated on one digital indicator **dpm**.

By means of a rotary switch the desired measurement point can be selected. The associated processor digital indicator **dpm** is accommodated together with the measurement point selector in a common DIN panel housing.

The unit is available in the versions Pt100, ammeter (0/4-20mA) and voltmeter (0-10V).

Features

- 10 inputs selectable for indicator
- 3 pole selection
- suitable for Pt100 3 wire or 4 wire connection
- digital indicator and selector in common housing
- closed current loops on ammeter input
- lighted customized signal unit marking
- plug-in terminal blocks
- CE-mark

Options

- 2 or 4 alarm outputs
- analog output



Specification

Style	panel mount case	96x96x130mm with 2 side mounting clips
Panel cutout	(WxH)	92x92mm tol. -0,5mm
Enclosure code	front/rear	IP54/IP20
Ambient	operating temp.	0...+50°C
	shelf temp.	-20...+70°C
	humidity	0...95% no condensate
Connection	Sub-D-connector	50 pin and companion plug (solder connect.)
Input	Pt100	3 wire or 4 wire
	voltmeter	0-1V, 0-10V ($R_i=50k\Omega$)
	ammeter	0/4-20mA ($R_i=50\Omega$ each input)
Switch	12 positions	30° increments, 3pol., short circuit
	contact resistance	<50m Ω , contact material silver 6 μ m
	life time	>25000 switching cycles
Indicator	7-segment	-1999...+9999
Sensor supply	short-circuit proof	approx. 25V DC, 30mA max.
Supply voltage	AC	230V AC, 50Hz
	DC	20...30V DC <0,3A

Order Designation and Type Key

input type	designation
Pt100 input	dmu-dpm-pt
ammeter	dmu-dpm-gs-0/4-20mA
voltmeter	dmu-dpm-gs-0-10V

Pt100 4 Wire Connection

- Pins 1, 5, 9, 13, 18, 22, 26, 30, 34, 38 and 47 are connected internally. Pin 47 is connected with the GND terminal of digital indicator dpm-pt (pin 4).
- 3 pole selection of measurement points
- Switch SS2 of dpm-pt is set to position "4".

Pt100 3 Wire Connection

- Pins 1, 5, 9, 13, 18, 22, 26, 30, 34, 38 and 47 are connected internally. Pin 47 is connected with the GND terminal of digital indicator dpm-pt (pin 4).
- 3 pole selection of measurement points
- Die gestrichelt drawn connections are eliminated.
- Switch SS2 of dpm-pt is set to position "3".

Ammeter Connection

- Connect pin 48 to input E3 of digital indicator dpm-gs (terminal 2) and pin 50 to GND of digital indicator (terminal 4).
- Connect all measurement points as shown in Fig. connection diagram dmu-dpm-gs 0/4-20mA.
- Each measurement circuit has a separate burden resistor (50Ω) mounted in the unit. Hence all current loops remain closed in every switch position.
- The digital indicator works on input type 0/4-20mA.
- Both poles are selected.

Voltmeter Connection

- Connect pin 48 to input E2 of digital indicator dpm-gs (terminal 2) and pin 50 to GND of digital indicator (terminal 4).
- Connect all measurement points as shown in Fig. connection diagram dmu-dpm-gs 0-10V.
- The digital indicator works on input type 0-10V.
- Both poles are selected.

Operation and General Instructions

Solder the individual measurement leads to the 50-pin D sub receptacle furnished. Connect the output leads (pin 47...50) to the input of the corresponding digital indicator dpm-... . For operation and setting of the digital indicator dpm see corresponding data sheet.

Connection Diagram dmu-dpm-pt (3 and 4 wire)

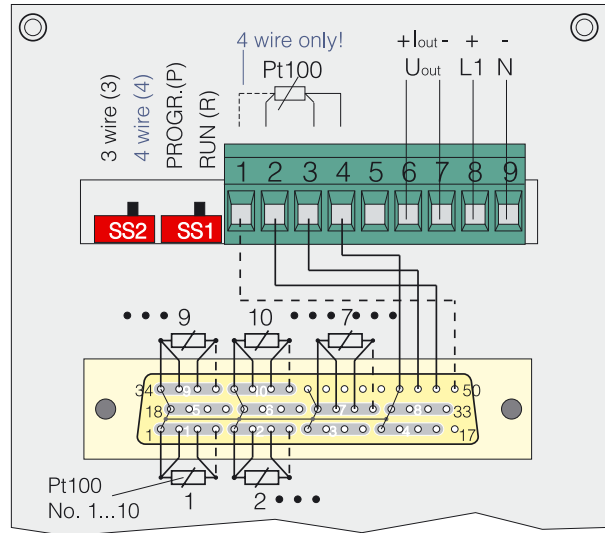

Connection Diagram dmu-dpm-gs 0/4-20mA

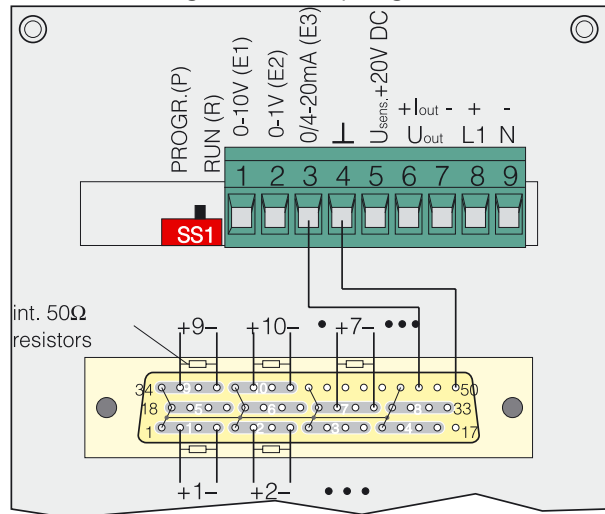

Connection Diagram dmu-dpm-gs 0-10V

