



# READ THIS FIRST

## Installation and Startup Guide

# “D3” Differential Pressure & Level Transmitter

Version 1.1 Document 10022



**Anderson-Negele**  
Anderson Instrument Co., Inc.  
156 Auriesville Rd., Fultonville, NY 12072  
Phone: 518-922-5315  
Fax: 518-922-8997

[www.anderson-negele.com](http://www.anderson-negele.com)

### PRODUCT DESCRIPTION

The Anderson-Negele D3 Differential Pressure and Level Transmitter has been designed to measure process pressure or hydrostatic level in sanitary process applications. The state-of-the-art temperature compensation reduces errors associated with process temperature changes and with improved zero stability reduces sensor interaction. The graphical user interface makes set-up and programming easy. The field repairable and reconfigurable design allows the user to change the display orientation, add a remote cable, or replace a component in the field without impact to accuracy.

### SENSOR WIRING

To facilitate electrical connections the D3 transmitter will be provided with either a 5 pin M12 quick disconnect receptacle, a M16 thread cable gland, or a 1/2" NPTF threaded adaptor. Shielded cable is recommended. See manual for additional detail.

Field wireable connectors or molded cordsets are available as accessories from Anderson-Negele.

### FIELD WIREABLE CONNECTOR ASSEMBLY - ORDERED AS ACCESSORY

1. Insert cable through Pressing Screw, Compression Ring, Seal Grommet, and Sleeve as shown below.
2. Strip back 1-1/4" of outer sheathing, cut off any excess wires, shield and ground. Strip off 1/4" insulation from remaining two wires. It is not necessary or recommended
3. Orient Connector end so that center pin connecting screw is horizontal facing right (see detail).
4. Wire Loop 1+ (red wire) to top right terminal, Wire Loop 1- (black wire) to top left terminal, Wire loop 2+ (green wire) to bottom left terminal, and Wire Loop 2- (Brown wire) to the bottom right terminal. No connection is made to the center terminal

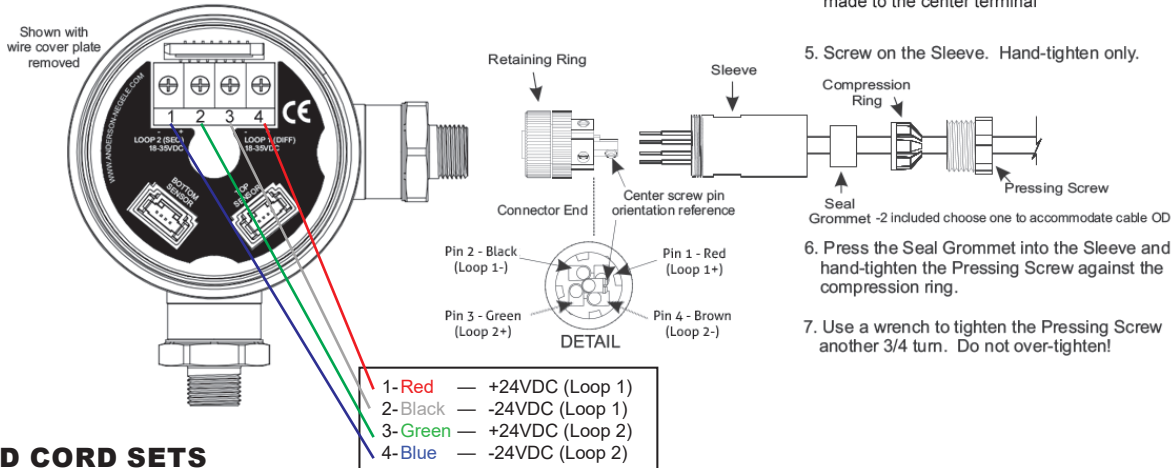

5. Screw on the Sleeve. Hand-tighten only.
6. Press the Seal Grommet into the Sleeve and hand-tighten the Pressing Screw against the compression ring.
7. Use a wrench to tighten the Pressing Screw another 3/4 turn. Do not over-tighten!

### MOLDED CORD SETS

#### Anderson-Negele Cord Set



#### Typical Cord Set by Others



## USER INTERFACE GUIDE

The D3 transmitter may be configured via the onboard 4 button display. This section will describe configuration through the onboard display.

Configuration menus are shown graphically in the manual along with the resulting actions from pressing any of the buttons.

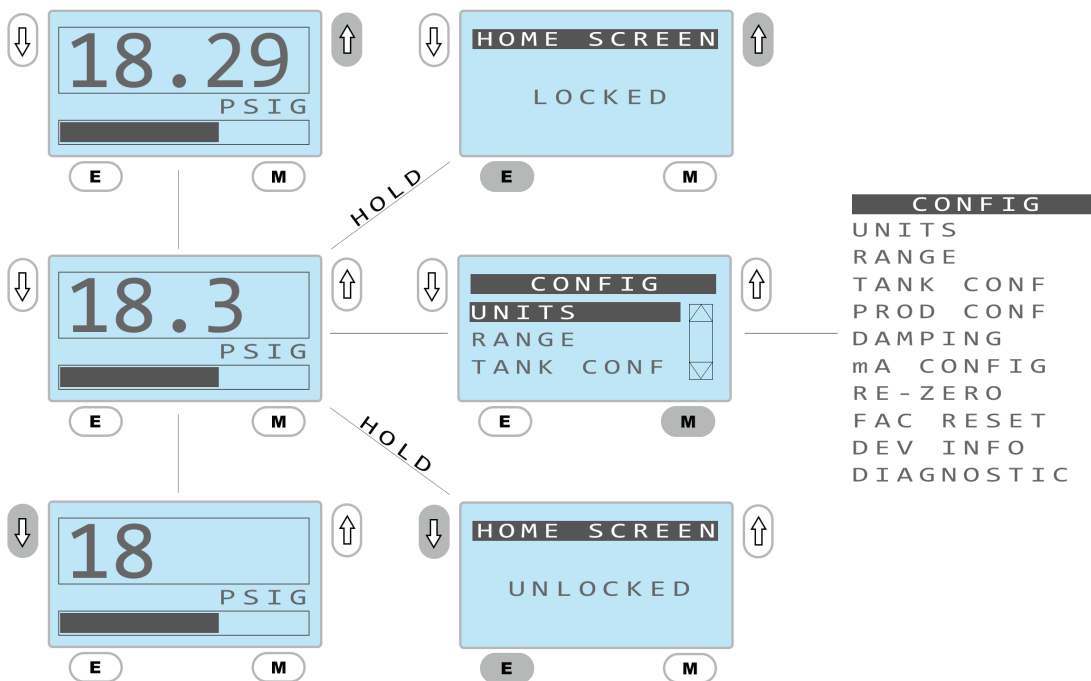
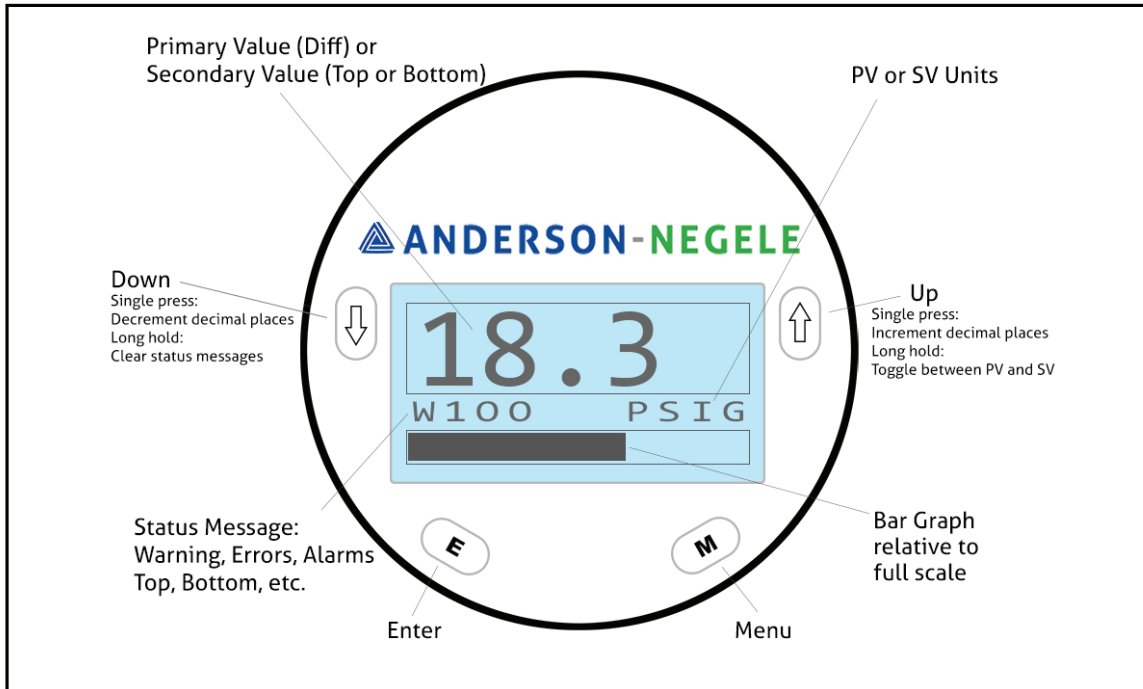

Pressing "M" will display menu.

Pressing "E" will temporarily display an explanation of the numerical status message.

Pressing "Down" or "Up" will decrement or increment decimal places of PV or SV.

Pressing "E" and "Up" will lock the home screen. Menu cannot be accessed when home screen is locked.

Pressing "E" and "Down" will unlock the home screen.

Pressing and holding "Down" will clear warning messages.

Pressing and holding "Up" will toggle between PV and SV.

## mA Calibration

When a transmitter is added to a system for the first time a mA calibration should be performed to ensure the sensor's 4mA and 20mA points align with the control system in which it is installed. Because input cards are variable this will provide the best results and avoid programming an offset in the PLC.

The mA calibration requires the device to be installed in a control loop where the mA value may be read or observed by the operator and the display may also be accessed.

The mA calibration needs to be performed for both Loop1 and Loop2

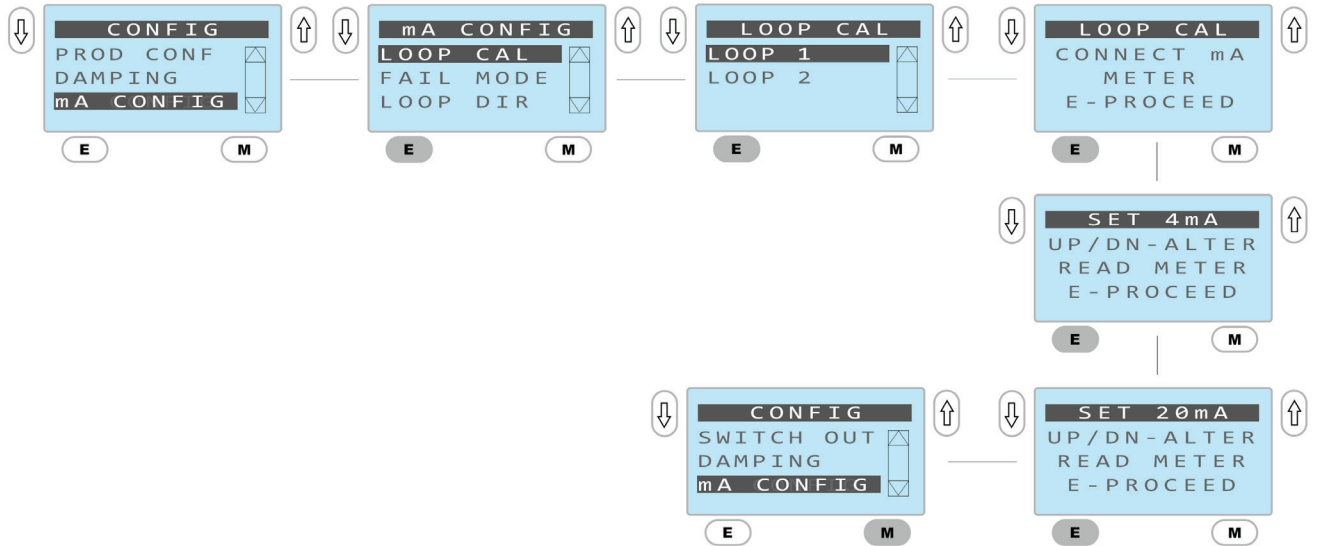

## Failure Mode Selection

The D3 may be set to fail low (3.8mA output) or fail high (20.2mA output) when a valid process variable cannot be output.

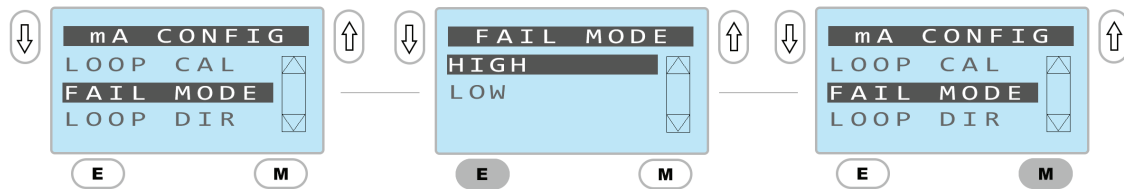

## Re-zero

The D3 transmitter is sensitive to both orientation and clamping forces during installation. It is important to re-zero the sensor after it has been installed. Additionally, if the diaphragm is dented or goes through a period of stress such as being steamed for the first time, it is important to re-zero the sensor.

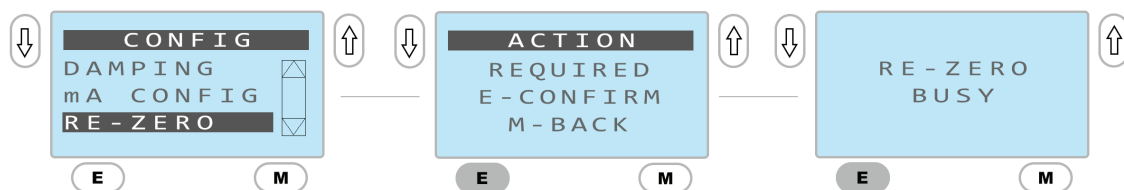

## EXPLODED VIEW

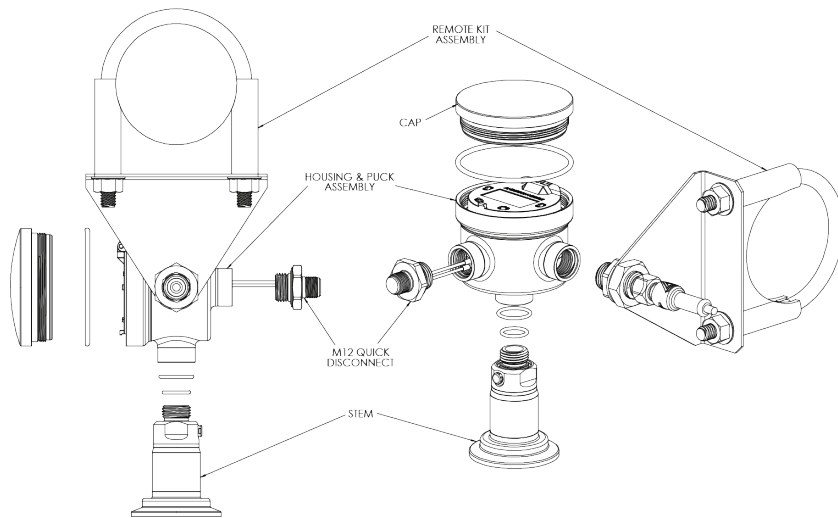

## ACCESSORIES

### Cord Sets

Shielded Molded w/25' cable	42117H0025
Shielded Molded w/50' cable	42117H0050
Shielded Molded w/100' cable	42117H0100

Clear Cap w/gaskets	56328P0001
Stainless Steel Cap w/gaskets	56329P0001
M12 Quick Disconnect Receptacle	SP56726A0004
Cord Grip	SP5633100000
1/2" NPTF adaptor	SP5633200000
Seal Kit (6) gaskets	5633000001
Field Wireable Connector-Straight	42119B0000
Field Wireable Connector-90°	42119A0000
10' Remote Kit	SP73228A0010
25' Remote Kit	SP73228A0025
50' Remote Kit	SP73228A0050
Rosemount/Foxboro Clamp Connection	46600A00010

## DIMENSIONAL DRAWINGS

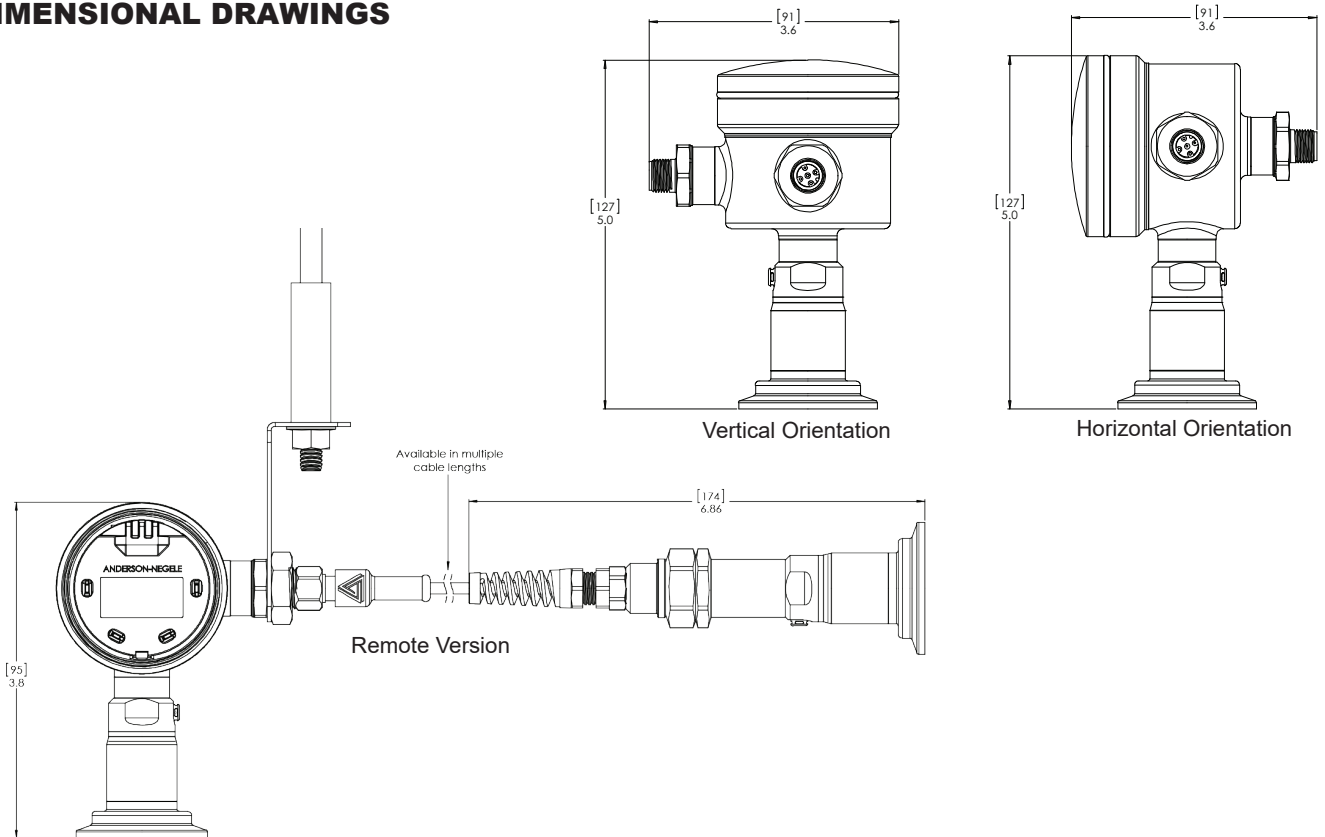

## Warnings



**Warning!**

This unit accepts DC voltage only, connection to AC voltage can cause failure of the sensor and/or risk of electrocution



**Warning!**

Do not remove this sensor from the process while it is operating. Removal while the process is operating can contaminate the process and could cause human injury.



**Warning!**

Before removing for service or calibration, ensure that residual product has been flushed from the line and that internal pressure has returned to atmospheric pressure.