

Instruction Manual



Anderson Instrument Co. Inc.
156 Auriesville Road
Fultonville, NY 12072
1-800-833-0081
www.anderson-negele.com

ANDERSON-NEGELE

Instrument Model Number _____

Instrument Serial Number _____

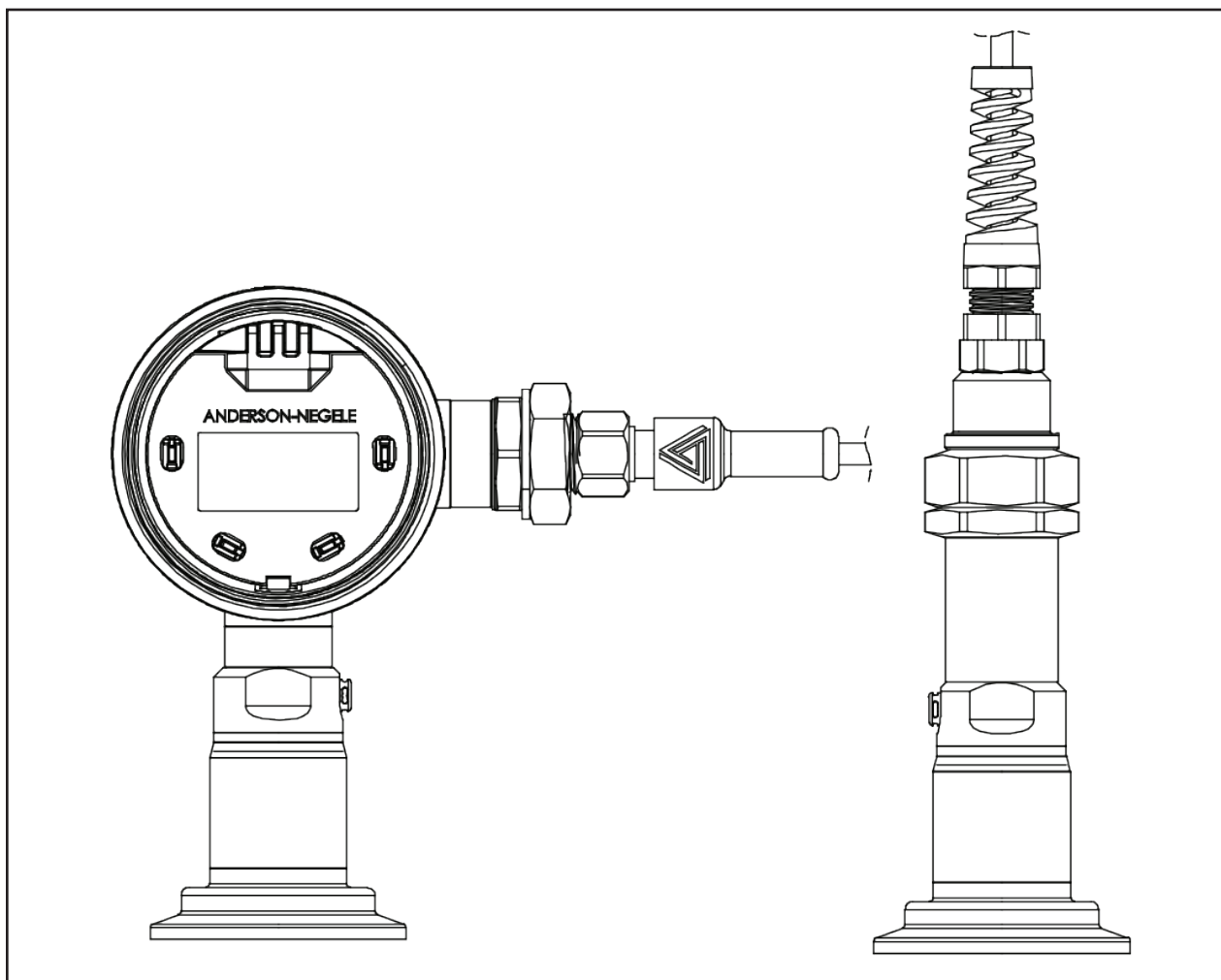

"D3" Differential Pressure and Level Transmitter

Table of Contents

Section 1 - Introduction	5
1.1 Specifications	5
1.2 Warnings	6
1.3 Dimensional Drawings	7
Section 2 - Theory of Operation and Description	8
Section 3 - Installation	8
Section 4 - Sensor Wiring	9
4.1 M12 Quick Disconnect Connection	9
4.2 Direct Wiring	9
Section 5 - Instrument Wiring	10
5.1 Loop Power	10
Section 6 - Modular Assembly	11
6.1 Separation of the Sensor (Stem) from the Transmitter (Head)	11
6.2 Replacement of the Sensor (Stem)	11
6.3 Replacement of the Transmitter (Head)	11
6.4 Replacement of the Electrical Receptacle	12
6.5 Changing the Orientation	12
6.6 Installing or replacing the remote transmitter kit	13
Section 7 - Configuration	14
7.1 - Home screen navigation	14
7.2 - Units	16
7.3 - Range	18
7.4 - Tank Configuration	19
7.5 - Product Configuration	22
7.6 - Dampening	22
7.7 - mA Configuration	23
7.8 - Re-zero	24
7.9 - Factory Reset	24
7.10 - Device Information	24
Section 8 - Maintenance/Diagnostics	25
8.1 - Error Codes	26
Section 9 - Warranty and Return Statement	27

Section 1 - Introduction

1.1 Specifications

Measuring range URL [bar] Measuring range URL [psi]	Relative Relative	-1...35 -14.7...500
Overpressure strength	Factor	1.5 x nominal pressure of measuring element
Measurement accuracy	Differential error Secondary output (SV) Error Repeatability Long-term stability	+/- 0.15% (DIFF _{URV} +TOP _{URV}) +/-0.15% (SV _{URV}) 0.05 % 0.2 % URL every 2 years
Temperature effect	Process Ambient	< 0.016 % of calibrated measuring range / 5.5 °C (10 °F) < 0.016 % of calibrated measuring range / 5.5 °C (10 °F)
Temperature range	Process Ambient CIP/SIP Cleaning	-18...110 °C (0...230 °F), at ambient ≤ 71 °C (160 °F) -18...71 °C (0...160 °F) 130 °C (266 °F) for 1 hour when ambient is below 60 °C (140 °F)
Response time		< 0.2 seconds
Sample rate		< 0.05 seconds
Materials	Connection head Metal cover Plastic cover Threaded connector Wetted parts Diaphragm Diaphragm seal/oil filling	Stainless steel, AISI 304 (1.4301), R _a ≤ 0.8 µm (32 microinch) Stainless steel, AISI 304 (1.4301), R _a ≤ 0.8 µm (32 microinch) Polycarbonate Stainless steel, AISI 304 (1.4301), R _a ≤ 0.8 µm (32 microinch) Stainless steel, AISI 316L, R _a ≤ 0.64 µm (25 microinch) Stainless steel, AISI 316L, R _a ≤ 0.64 µm (25 microinch) Medical white oil / mineral oil / paraffin oil FDA approval number 21CFR172.878, 21CFR178.3620, 21CFR573.680 Neobee M20 (optional)
Process connection	3-A compliant not 3-A compliant	1-1/2" Tri-Clamp® 2" Tri-Clamp® 2½" Tri-Clamp® 3" Tri-Clamp® AIC CPM Flush Mount Anderson Flush Mount Short (71060-A4, A6, A8) Anderson Flush Mount Long (71060-A3, A5, A7, A9) Rosemount/Foxboro Sanitary Spud - Short and Long Endress & Hauser Universal Adaptor - Short and Long M38x1.5 G1" 1-1/2" NPT 2 G1" Fixed Thread 38mm SMS Liner (female) 51mm SMS Liner (female) 40mm DIN 11851 (Milk Coupling) 50mm DIN 11851 (Milk Coupling) DRD-SMS DIN11851
Electric connection	Cable gland Plug-in connection	M16x1.5 M12 plug, 5-pin, 1.4305
Approvals		3A CE Compliant CRN (CSA-B51-03)* CSA22.2 IP 67 (with cable gland) / NEMA 4X IP 69 K (with plug-in M12 connection)
Auxiliary Power Supply	Voltage Current Limit	18...35 V DC 4.2 A
Output	Loop 1 (Differential Pressure) Loop 2 (Top or Bottom Pressure)	analog 4...20 mA analog 4...20 mA
Tightening torque	For assembly all D3 components	27 Nm (20 ft-lbs)
Weight		approx. 3.5 kg

*consult factory for regions and configurations

1.2 Warnings



Warning!

This unit accepts DC voltage only, connection to AC voltage can cause failure of the sensor and/or risk of electrocution



Warning!

Do not remove this sensor from the process while it is operating. Removal while the process is operating can contaminate the process and could cause human injury.



Warning!

Do not subject this sensor to pressure that exceeds the specified upper range limit. Over-pressure may cause premature failure, incorrect output signal, or possible human injury.



Warning!

Before removing for service or calibration, ensure that residual product has been flushed from the line and that internal pressure has returned to atmospheric pressure.

1.3 Dimensional Drawings

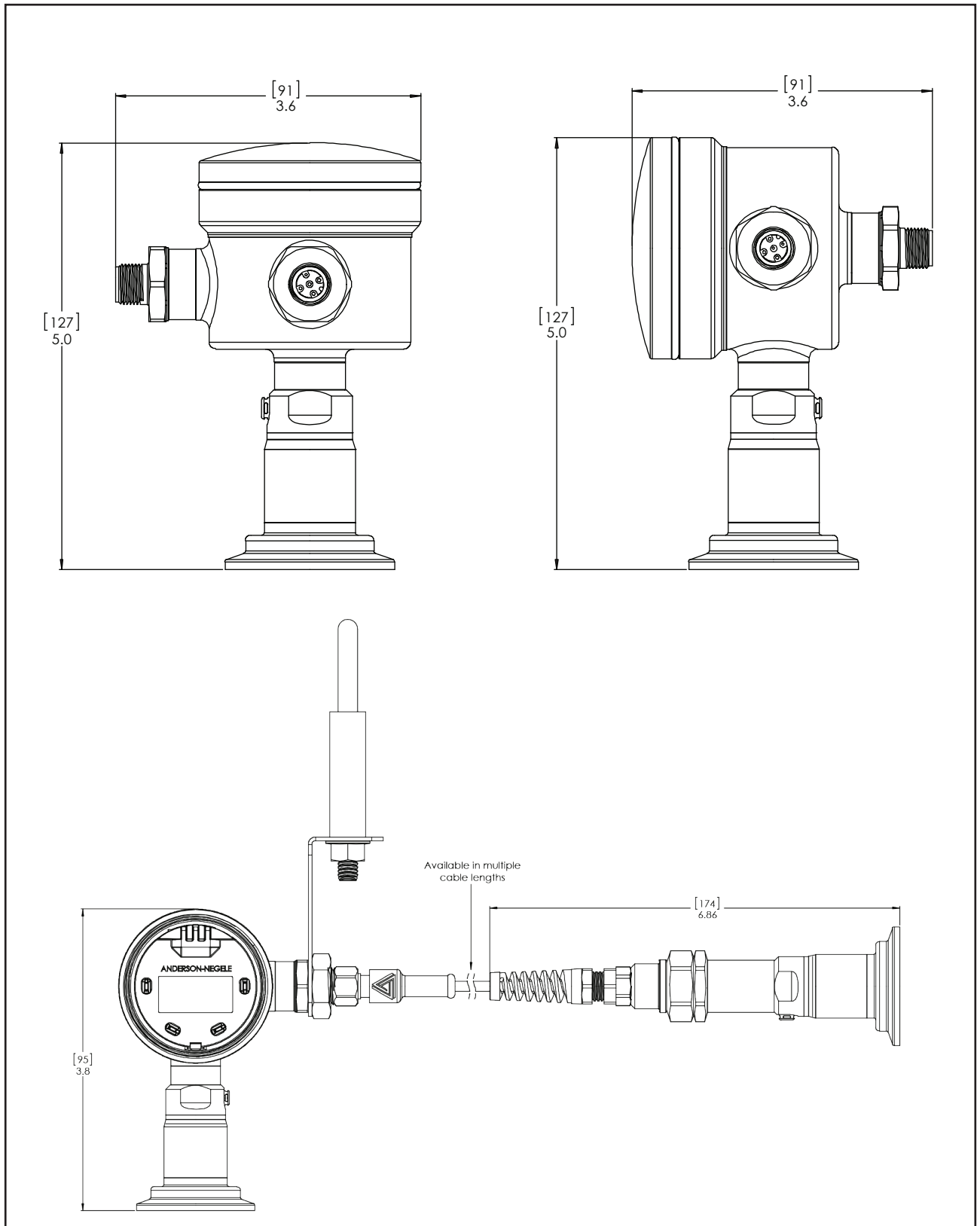

Section 2 - Theory of Operation and Description

The Anderson-Negele D3 Differential Pressure and Level Transmitter may be used in applications where an analog output proportional to process pressure, hydrostatic head, or the volume or mass of a vessel's contents is needed for process or inventory control. This unit utilizes an internal piezoelectric transducer and an RTD temperature element to measure the pressure and temperature of the internal actuating fluid. The mV signal of the transducer and resistance of the RTD are measured and converted to a compensated pressure value by way of the signal acquisition board in the stem. This signal is digitally communicated to the head where the signal is converted to the industry standard 4...20mA signal. For relative sensors the back of the diaphragm is vented and the output is relative to the atmospheric conditions. In the case of the absolute sensors the measurement is relative to a theoretical perfect vacuum therefore the signal will vary with atmospheric conditions.

The integral display and four button interface shows the process variable, a graphical representation of the output and allows reconfiguration of the unit including the configuration of tank geometry and product density.

The D3 Differential Pressure and Level Transmitter was designed specifically for liquid measurement applications in the food and beverage industry where accuracy in dynamic temperature environments is critical to process control. The measurement cell is integral to a welded sanitary diaphragm seal that is available in a variety of industry standard fitting styles and sizes. The process pressure deflects the metal diaphragm, transmitting the pressure to a transducer cell.

Section 3 - Installation

The physical installation is of the utmost importance with regard to sensor reliability. Transmitters must be installed in such a way that the device and cable are not subject to physical abuse. Additionally, moisture and or moist air must not be allowed to enter the sensor housing or cable.

NOTE: The installer assumes responsibility for preventing water or water-vapor from entering the sensor housing by proper installation of the cap and appropriate cable preparation. Units equipped with M12 Quick Disconnects are rated to NEMA 4X and IP69K. Cable gland equipped units are rated to NEMA 4X and IP67.

To facilitate electrical connections, your new D3 transmitter may be supplied with a 5pin M12 quick disconnect receptacle, an M16 cable gland, or a 1/2" NPTF threaded adaptor. If mounted horizontally, the cable connection should point downward. Also, to prevent entry of excessive moisture, it is highly recommended that conduits not be connected directly to the sensor. If conduit is to be run to the sensor, it is preferable that the watertight connector provided with each sensor not be removed from the sensor. Instead, run the flexible conduit as near to the sensor as possible and utilize a seal-tight connector at the end of the conduit. Allow a short amount of cable to run between the sensor and the flexible conduit. This isolates the sensor housing from the conduit system and any moisture it may contain. If the conduit is connected directly to the sensor, the chances are high that the sensor will eventually fail due to excessive water or water vapor entry into the housing.

NOTE: It is recommended that a sensor "Re-ZERO" be performed at time of installation. Refer to section 7.10, for information on this procedure.

NOTE: It is recommended that a mA calibration be performed after installing a transmitter in a loop for the first time. Refer to section 7.9

Section 4 - Sensor Wiring

WARNING! This unit accepts DC voltage only, connection to AC voltage can cause failure of the sensor and/or risk of electrocution

For wet environments requiring IP67 or greater environmental protection Anderson – Negele strongly recommends using the available shielded molded cord-sets utilizing the 5 pin M12 eurofast quick disconnect.

Anderson - Negele supplied cable meets all requirements for shielding and compatibility with the D3 quick disconnect receptacle. Anderson - Negele recommends a cable of 24 gauge, 4 conductor, shielded (Belden #9534) or equivalent. Four conductor cable is utilized because of its roundness as well as providing connections for both differential mA output and top or bottom sensor mA output. A round cable provides a suitable seal when used with seal-tight connectors, strain reliefs and rubber grommets. Irregular shaped cable does not allow for a watertight seal.

If utilizing customer supplied cable, select a round cable with 22-24 AWG wire and a shield. In order for the Anderson provided seal-tight connector to seal on the cable, the O.D. of the cable must be between 3/16" and 1/4". If smaller cable is utilized, a different neoprene bushing must be used (must be customer supplied).

If an alternate seal-tight type connector is going to be used, be absolutely certain that the rubber bushing will adequately seal on the cable. Do not use a connector intended for power cable (large inside diameter) if the sensor cable is only 1/4". Be sure to use Teflon thread tape when attaching the new seal-tight connector.

4.1 M12 Quick Disconnect Connection

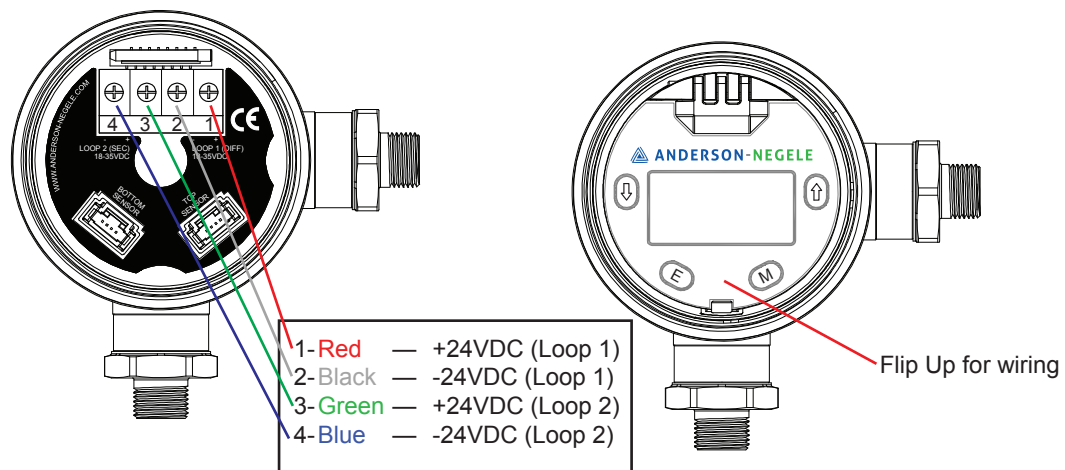

4.2 Direct Wiring

Direct wiring to the D3 transmitter is accomplished as follows:

1. Remove the housing cap and lift the hinged display lid by the pull tab to expose the terminals.
2. Insert the cable through the seal-tight connector, stripping back approximately 2 inches of sheathing to expose the wires.
3. RED (Loop1+) and BLACK (Loop1-) will be used for differential loop connection and GREEN (Loop2+) and BLUE (Loop2-) will be used for secondary (either top or bottom) loop connection. Trim off all unused wires, including the bare shield ground wire.

To prevent a GROUND LOOP condition, be sure the shield material and the shield ground wire do not touch the sensor housing. Use an insulator such as electrical tape or heat shrink tubing if necessary.

4. Strip the tips of the remaining wires back approximately 3/8 of an inch and twist strands (tinning is highly recommended).
5. Using Figure 2, make the proper connections to the wiring connector (located inside the housing)

Section 5 - Instrument Wiring

With the proper wiring connections made at the sensor end of the loop, it is now time to make final connections at the instrument end (input card) of the loop. The D3 may feed instruments such as Anderson - Negele digital display, microprocessor based controllers, chart recorders, or customer supplied instrumentation such as a PLC.

5.1 Loop Power

The Anderson D3 requires loop power for operation. Ratings are as follows:

D3 Transmitter: 18-35 VDC (Absolute), 24 VDC Nominal, regulated or unregulated.

As inherent resistance associated with cable length and signal receiver input may affect operation of the transmitter, Below shows some guidelines for loop power required.

Loop Power Guidelines

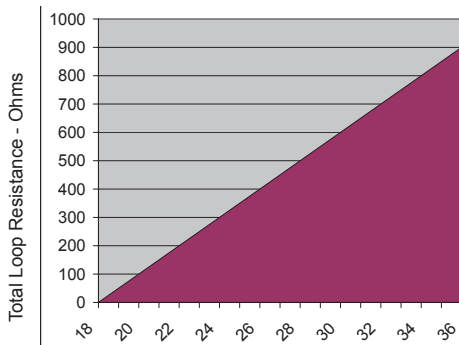

Loop Power Supply Voltage - VDC

Please consult the Installation/Service Manual that was provided with your receiver for specific wiring instruction. Most Anderson receiver (displays, chart recorders, etc.) are capable of supplying loop power. Typical wiring would be as follows:

Sensor Wiring

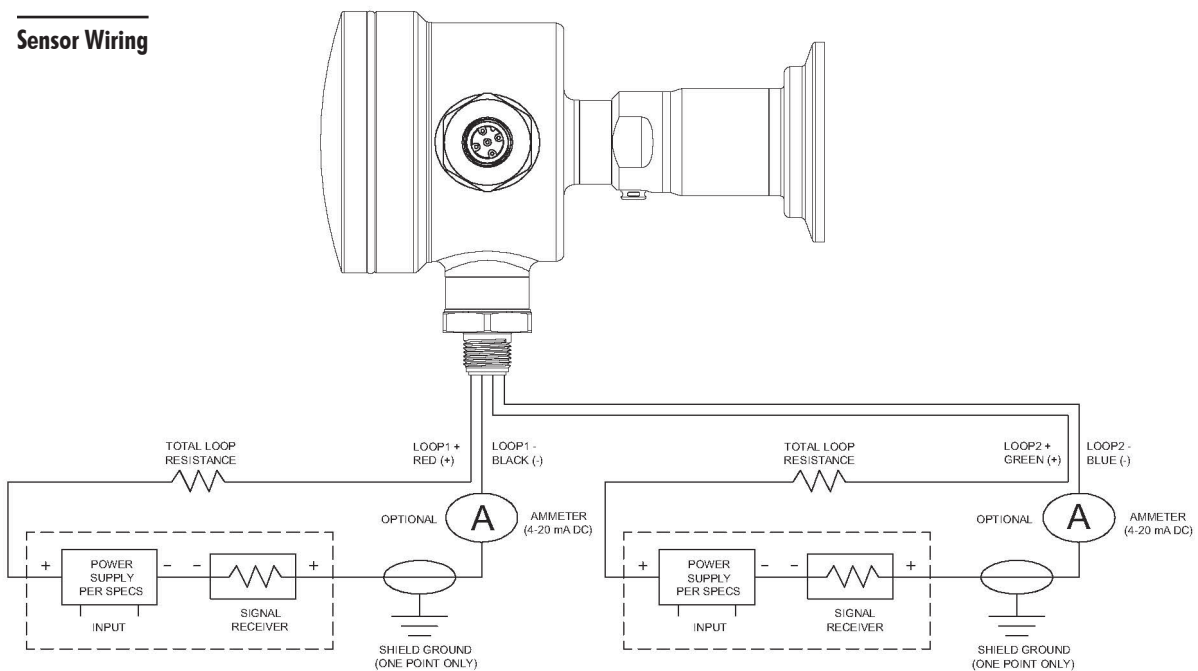

Section 6 - Modular Assembly

The D3 transmitter consists of two distinct sections, transmitter (head) and sensor (stem) which individually are comprised of one or more components. Field replacement of these components is possible to accommodate orientation reconfiguration and component replacement.

6.1 Separation of the Sensor (Stem) from the Transmitter (Head)

This proceed will require immobilizing the enclosure. If a vice is used steps should be taken to protect the surface of the enclosure

1. Remove the housing cap and lift the hinged display lid by the pull tab to expose the terminals and sensor connection
2. Gently squeeze clip connector and remove sensor ribbon from socket on transmitter
3. Unscrew stem from enclosure. Factory torque spec is 20ft-lbs.
4. Reverse to install

6.2 Replacement of the Sensor (Stem)

1. Replacement of the sensor will require separation of the sensor and transmitter. Please see section 6.1 above
2. Thread the replacement sensor into the desired transmitter opening (horizontal or vertical orientation) and tighten to 20ft-lbs.
3. Carefully insert the sensor clip connector into the socket on the transmitter
4. If a sensor of identical range is used no further action is required
5. If a new sensor range is connected please reconfigure the Range as shown in section 7.3
6. Reinstall the D3 transmitter in the process and perform a re-zero Section 7.10

6.3 Replacement of the Transmitter (Head)

1. Replacement of the transmitter will require separation of the sensor and transmitter. Please see section 6.1 above
2. Thread the replacement transmitter onto the sensor using the desired transmitter opening (horizontal or vertical orientation) and tighten to 20ft-lbs.
3. Reconfigure the following transmitter parameters:
 - Dimension and Density units Section 7.2 (only if volumetric or mass units are used)
 - Tank Configuration Section 7.4 (only if volumetric or mass units are used)
 - Product Configuration Section 7.5 (only if volumetric or mass units are used)
 - Primary Variable (PV) Units Section 7.2 if pressure units are used
 - Range Section 7.3 if pressure units are used
 - Confirm the Dampening value is set correctly Section 7.8
 - Complete the mA configuration Section 7.9
4. Reinstall the D3 transmitter in the process and perform a re-zero Section 7.10

6.4 Replacement of the Electrical Receptacle

This proceed will require immobilizing the enclosure. If a vice is used steps should be taken to protect the surface of the enclosure

1. Remove the housing cap and lift the hinged display lid by the pull tab to expose the terminals and sensor connection
2. Disconnect the 4 wires from the terminal block using a Philips screwdriver
3. Unscrew the electrical connector from the transmitter housing
4. Thread the replacement receptacle into the desired transmitter opening (horizontal or vertical orientation) and tighten to 20ft-lbs.
5. Reconnect the wires to the terminal block as shown in Section 4.
6. Push the hinged display lid closed and tighten the cap firmly back in place.

6.5 Changing the Orientation

1. Disassemble the transmitter by following steps 1-3 of Section 6.1 and steps 1-3 of Section 6.4
2. Swap the locations of the electrical connector and sensor in the transmitter housing and reassemble as described in steps 2-3 of Section 6.2 and Steps 4-6 of section 6.4.

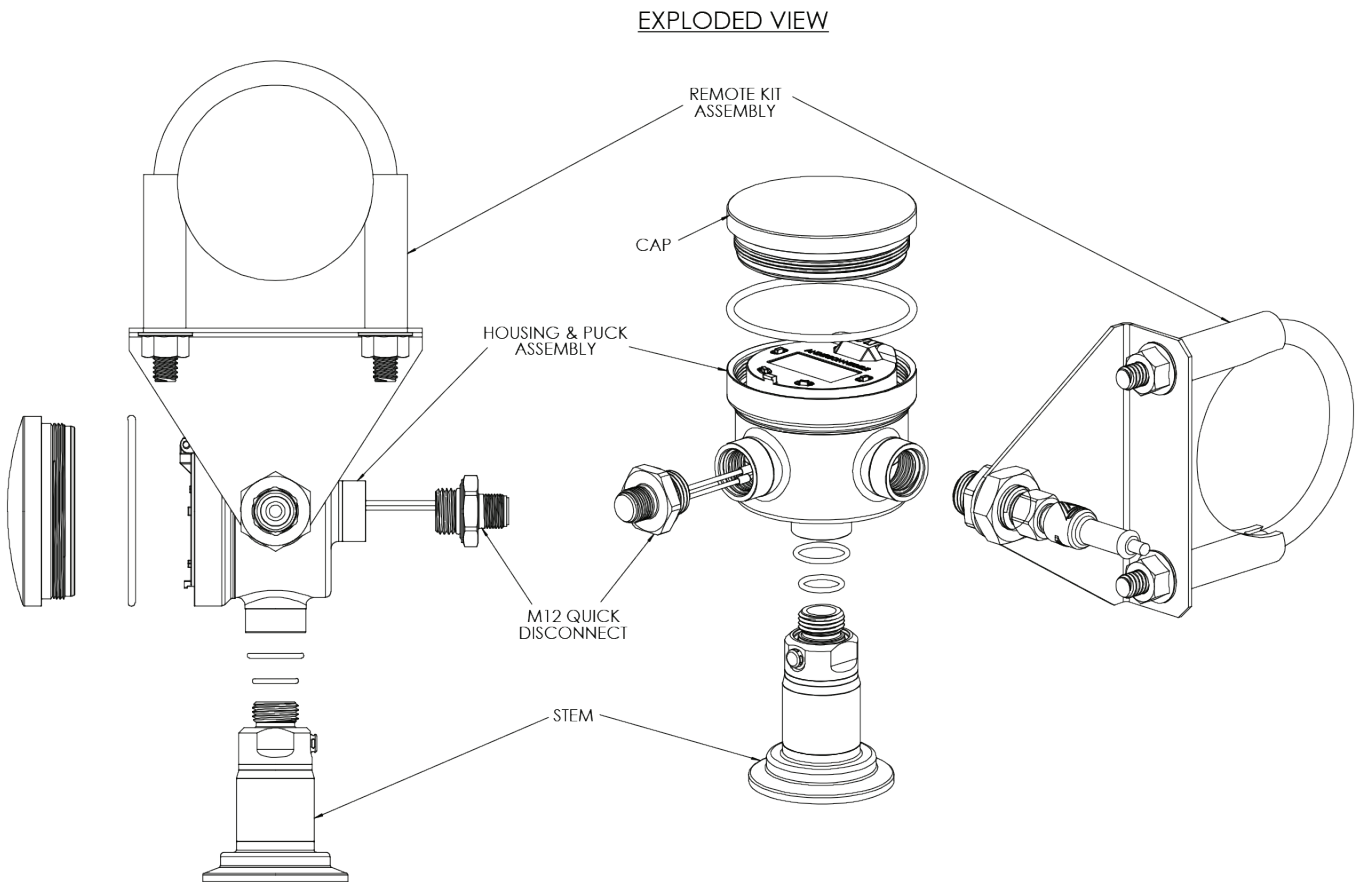

6.6 Installing or replacing the remote transmitter kit

The D3 series may be configured or retrofitted with remote cabling allowing the housing and display (if equipped) to be mounted up to 25 feet from the process connection. The remote cabling preserves the modular design and may be removed or added from the D3 at the user's discretion.

Adding the Remote kit.

Note: all threaded connections to be torqued to 20ft-lbs

1. Separate the Sensor (stem) from enclosure as described in Section 6.1
2. Attach remote kit cabling to sensor
 - Route stem ribbon cable through stem adaptor. Screw on adaptor
 - Connect ribbon cable connector to cable kit receptacle and carefully fold excess ribbon cable into stem adaptor
 - Insert cable kit fitting into stem adaptor. Secure by threading on union nut
3. Attach remote QDR adaptor to desired enclosure opening
 - Carefully insert ribbon cable through enclosure opening
 - Screw remote QDR adaptor into place
 - Connect ribbon cable connector into sensor receptacle on puck
4. Attach pipe mount adaptor to remote QDR adaptor and secure with nut. Position as required.
5. Attach remote kit M12 plug to remote QDR adaptor
6. Reverse to un-install.

WARNING! To avoid possible ribbon cable damage, remove union nut and unplug ribbon from socket before removing stem adaptor from stem.

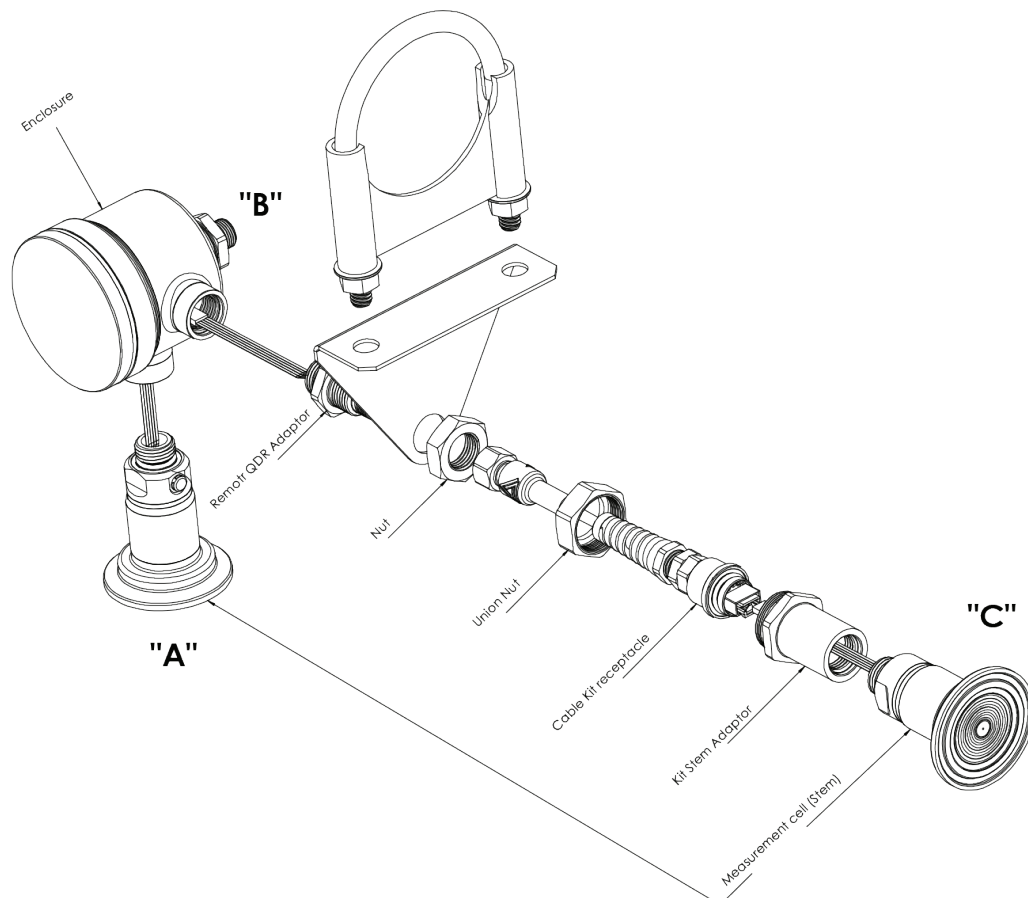

Section 7 - Configuration

The D3 transmitter is configured via the onboard 4 button display. This section will describe configuration through the onboard display.

Configuration menus are shown graphically in this manual along with the resulting actions from pressing any of the buttons.

7.1 - Home screen navigation

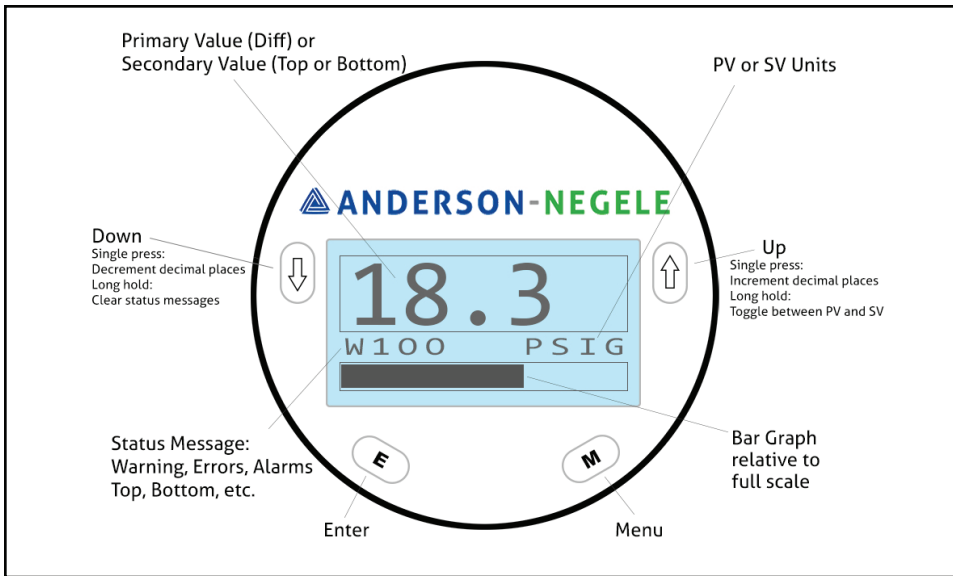

7.1.1 General Navigation

The general navigation scheme of the device is shown below:

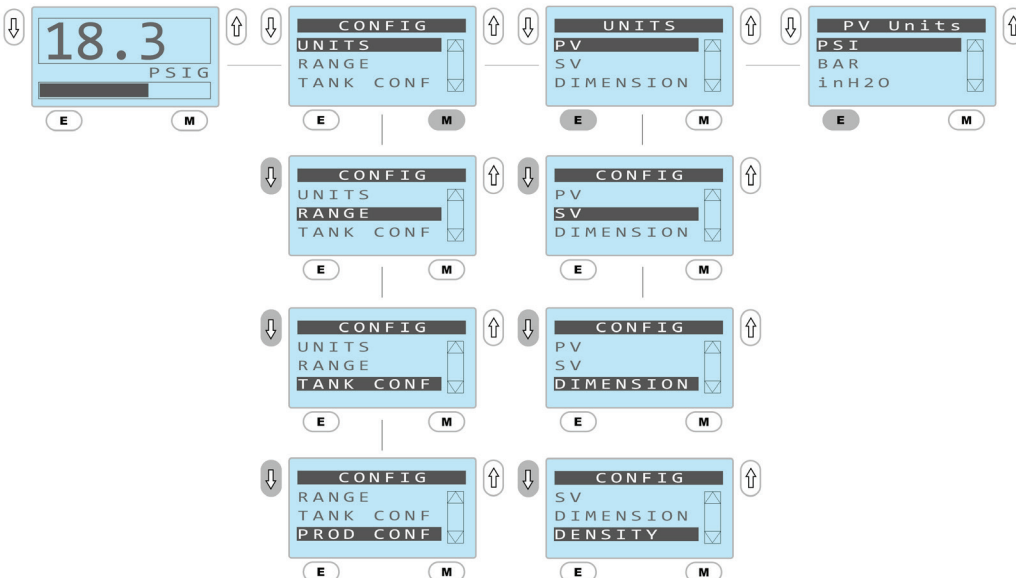

Pressing the up and down arrows moves the highlighted item.
 Pressing "E" while an item is highlighted selects that menu item
 Pressing the "M" button moves back one level

7.1.2 Lock/Unlock Home Screen

Pressing “E” and Up button locks the home screen. Menu cannot be accessed when home screen is locked. Pressing “E” and Down button unlock the home screen.

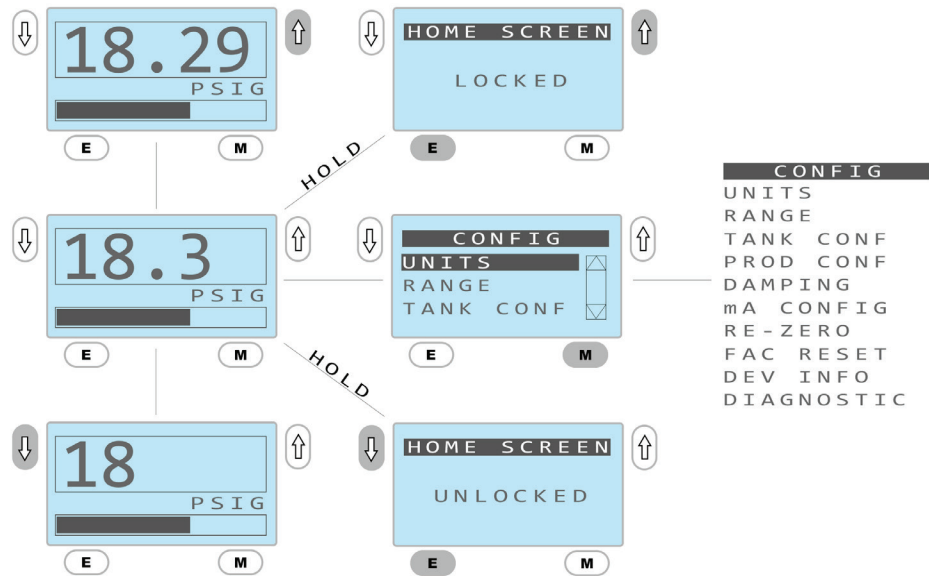

7.1.3 View Status Message

If a status message is present the following additional actions may be taken:
 Pressing “E” will temporarily display an explanation of the numerical status message
 Pressing and holding the down arrow will clear the warning message.

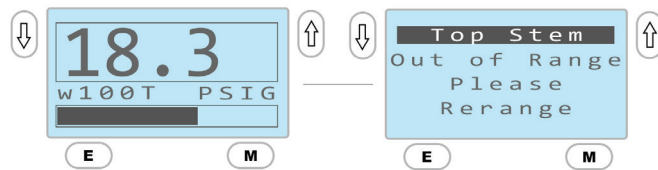

7.2 - Units

There are four units which may be chosen for the transmitter.

- **PV** – represents the units of the primary variable to be transmitted. This may be pressure, volume, or mass
- **SV** – represents the units of the secondary variable to be transmitted. This can be any of the available pressure units.
- **Dimension** – represents linear measurement units to be used when describing tank dimensions and may be chosen in Inches or meters
- **Density** – represents the density or specific gravity units products will be described with.

7.2.1 Units Configuration for Pressure Output

If the transmitter is to be used as a pressure measurement device or as a hydrostatic level measurement device with the following units of output this menu should be used: PSI, Bar, in of H2O, mm of H2O, mm of HG, mBar, or kPA

If Pressure units will be used, dimension and density units do not need to be chosen as tank and product configurations are not required.

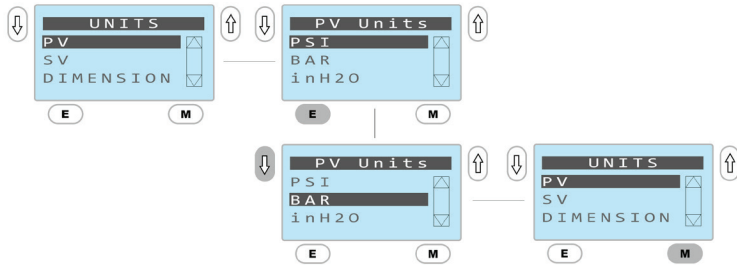

Once the desired units are highlighted pressing the “M” button will store the selection and move up one level in the menu. Once units are changed all unit dependent menus will change to those units. For example: range, etc

7.2.2 Units Configuration for Volume and Mass Outputs.

Units of volume and mass (KG, LB, Gallon, Liter, PCT vol) will output linearly with respect to those variables compensating for nonlinear portions of a vessel. The display will show the volume or mass located below the bottom of the sensor when no product is present and will respond after product covers the sensor diaphragm.

To configure a unit for volume or mass outputs the following actions must be taken.

1. Choose the dimension units as shown:

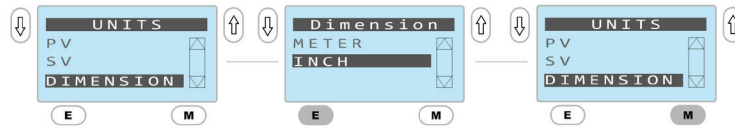

2. Select the density units as shown:

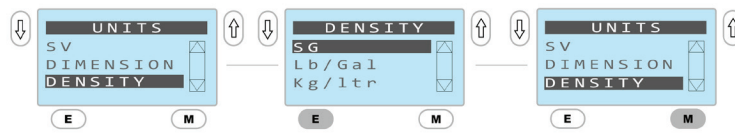

*note SG refers to specific gravity

3. Complete the tank configuration as shown in section 7.4
4. Complete the product configuration as shown in Section 7.5
5. Return to the Units menu to configure the primary variable (PV) units as shown:

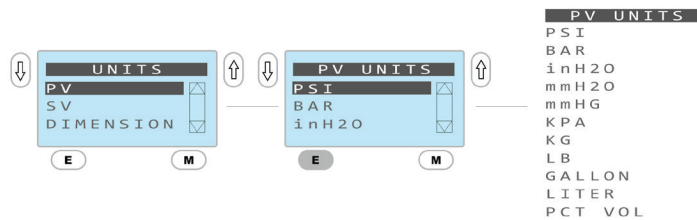

*Once a tank is selected and density is entered the full list of units is available

Once the desired units are highlighted pressing the “M” button will store the selection and move up one level in the menu. Once units are changed all unit dependent menus will change to those units. For example: range, etc.

7.3 - Range

The Lower Range Value (LRV) and Upper Range Value (URV) may be chosen when the sensor is used with pressure units. When volume, or mass units are used the LRV and URV are calculated automatically but may be viewed to aid in PLC programming. The D3 is also capable of setting the span based on the pressure applied to it (autospan).

7.3.1 Configuring Range for Pressure Output

The menu below shows adjustment of the LRV and URV for pressure output ranges. It should be noted that the PV units should be set to the desired units before performing this action.

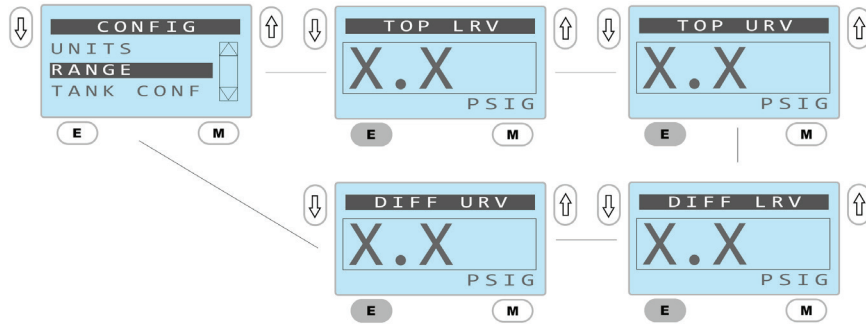

When the LRV or URV is displayed the Up and Down arrows may be used to adjust the value as desired. The LRV may be set from vacuum to 0 for gauge sensors, except 5 PSI sensors which are adjustable from -5 PSI to 0 (the LRV is not adjustable for absolute sensors).

The URV may be set from 10% of the sensor limit up to the sensor limit.

7.3.2 Viewing Range for Volume and Mass Outputs

When in volumetric or mass units the LRV and URV are calculated automatically based on the tank dimensions and product density. The calculated values may be viewed as follows:

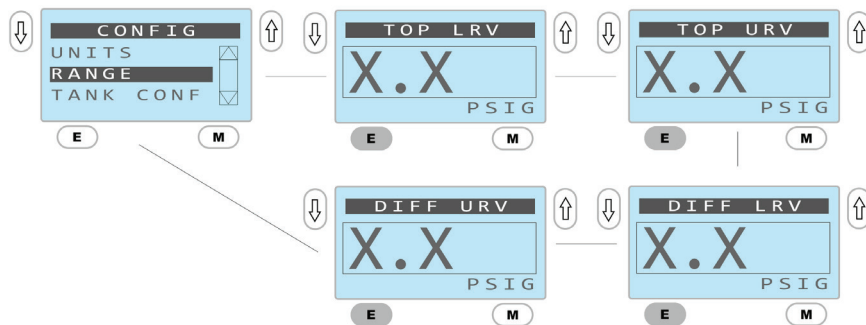

7.4 – Tank Configuration

To configure tanks, drawings or measurements must be available. Tanks must be configured to use volume, or mass units. Dimensional units should be chosen as shown in section 7.2.2. The tank type should be chosen as follows:

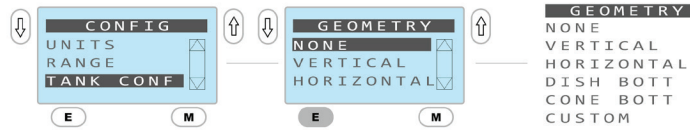

If tank dimensions are not entered or are not compatible with the sensor range the following message will appear.

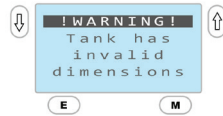

When this message is displayed the geometry menu cannot be exited until the dimension error is fixed unless tank geometry of “none” is selected.

7.4.1 – Vertical Tanks

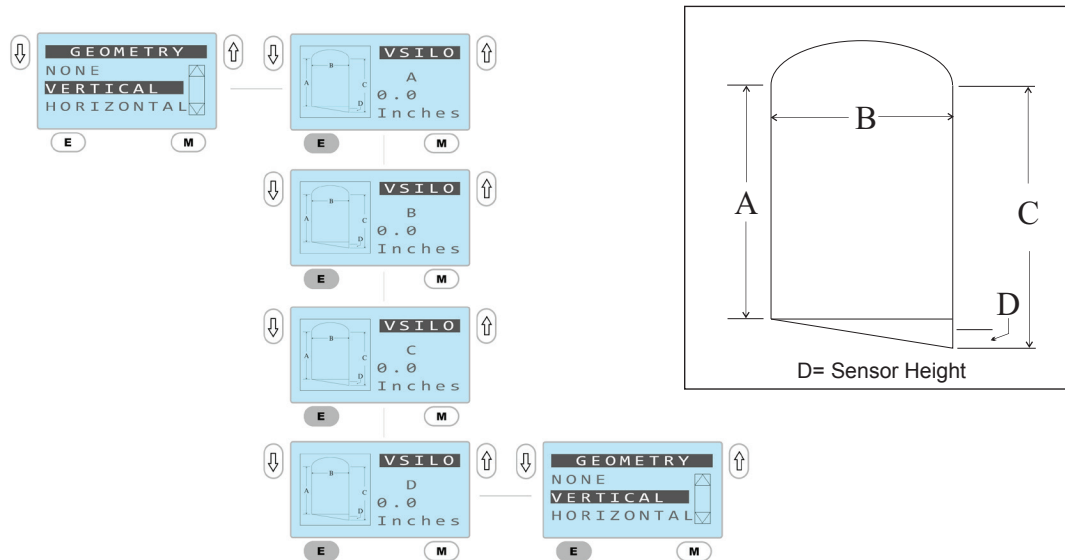

Increment the value of each dimension using the up and down arrows until the desired measurement is set. Press “E” to move to the next dimension.

7.4.2 – Horizontal Tanks

Dish ends are per the ASME standard

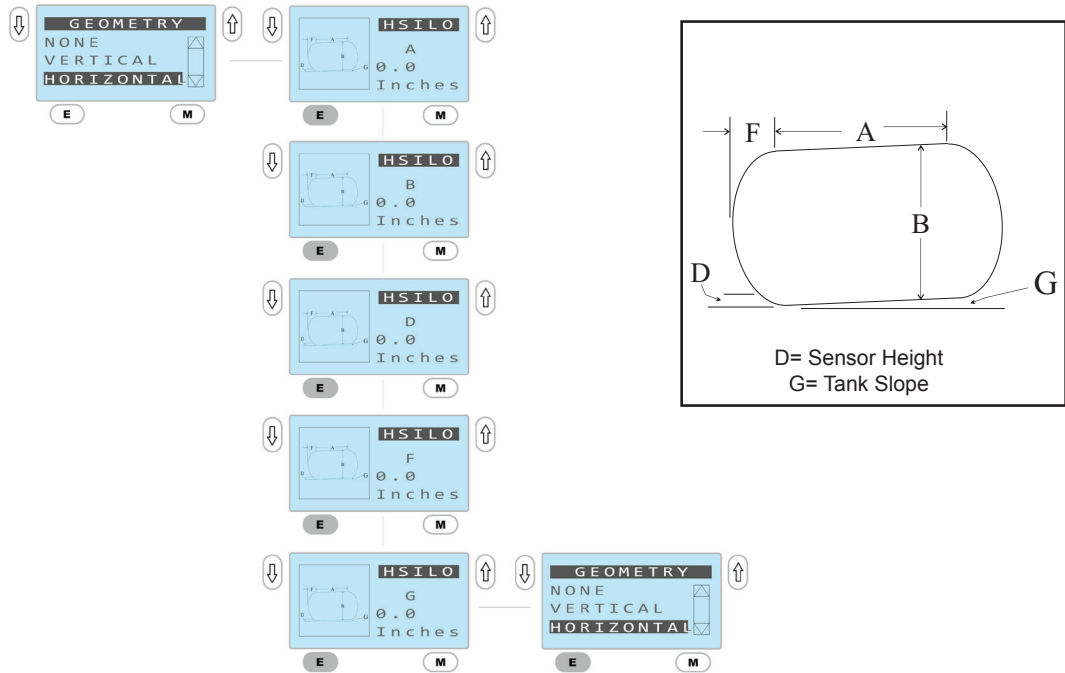

Increment the value of each dimension using the up and down arrows until the desired measurement is set. Press “E” to move to the next dimension.

7.4.3 – Dish Bottom Tanks

Dish bottom is per the ASME standard

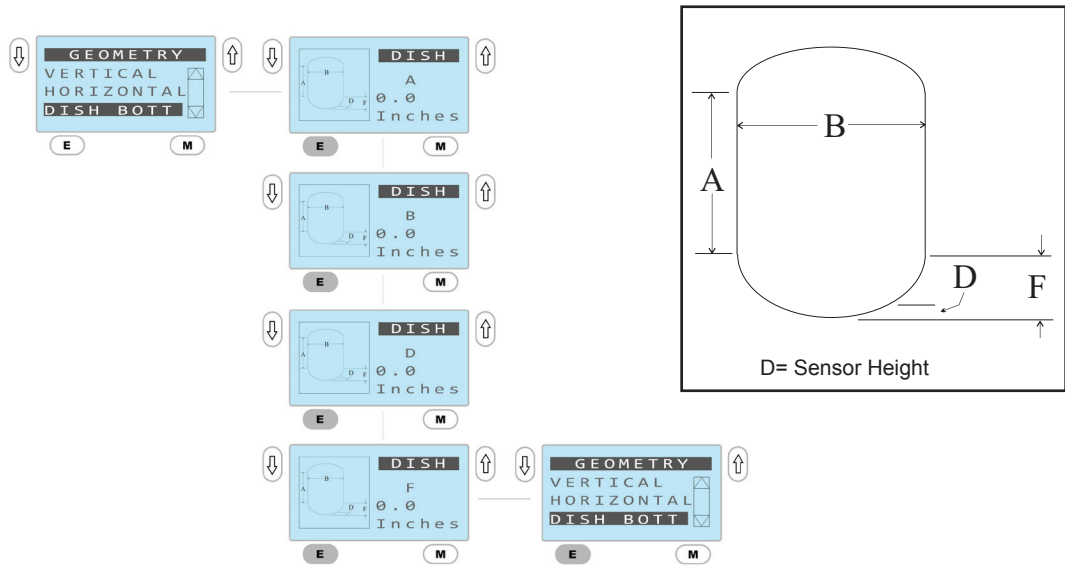

Increment the value of each dimension using the up and down arrows until the desired measurement is set. Press “E” to move to the next dimension

7.4.4 – Cone Bottom Tanks

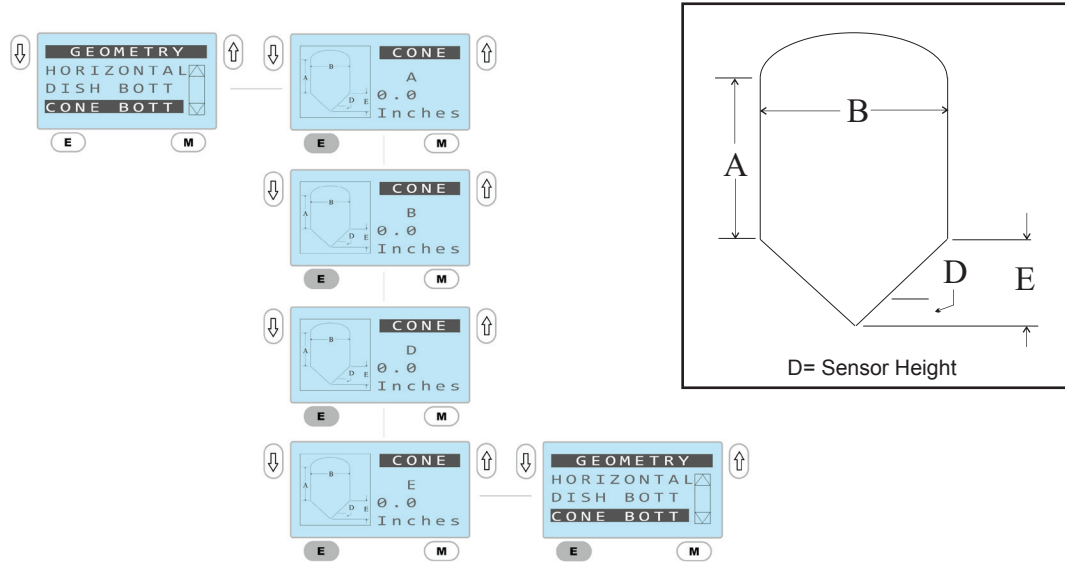

Increment the value of each dimension using the up and down arrows until the desired measurement is set. Press “E” to move to the next dimension

7.4.5 – Custom Tanks

If the desired tank geometry is not available or tank drawings or dimensions are not available a wet calibration may be done to configure a custom tank. Please note this procedure requires a reference flow meter and must be done sequentially while filling the vessel*. The user must decide the number of points required and then pump the amount of process fluid into the vessel and assign that value. The process is a guided as shown below:

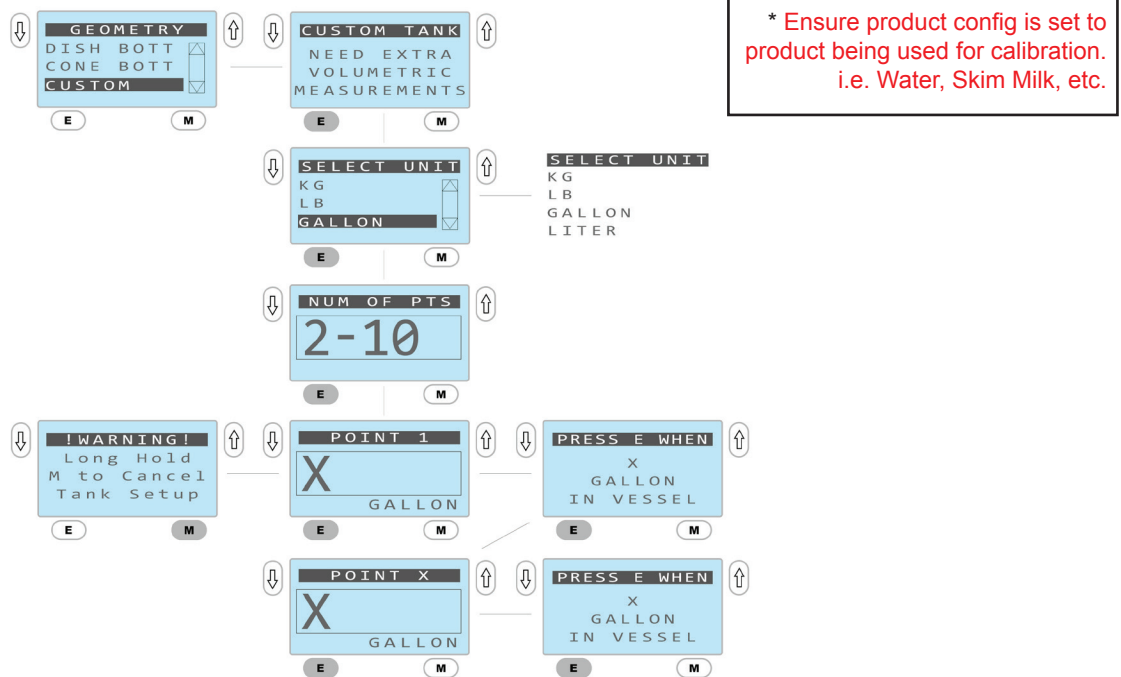

The up and down buttons may be used to select the number of points and the volume or mass present in the vessel.

7.5 – Product Configuration

Use of volume or mass units requires the selection of a product density. For the convenience of the user 10 common products are pre-loaded on the device and an additional 5 custom products may be stored at a time. When a new product is put in a tank it is important to change the product configuration to avoid errors in output due to changes in density.

7.5.1 Selection of Pre-loaded Products

Pre-loaded products may be chosen from the product configuration menu as shown:

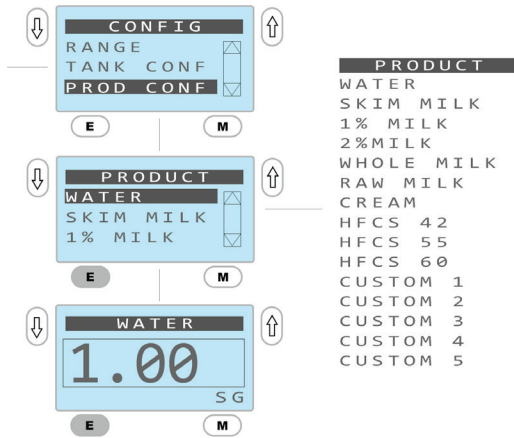

10 products come pre-loaded with densities in the units chosen. Adjustments can be made with the up and down buttons when the value is shown.

7.5.2 Configuration of Custom Products

If the customer's product is not preloaded it may be programmed as one of the available 5 custom products. Once configured with a name and density value the custom product may be highlighted to select for use.

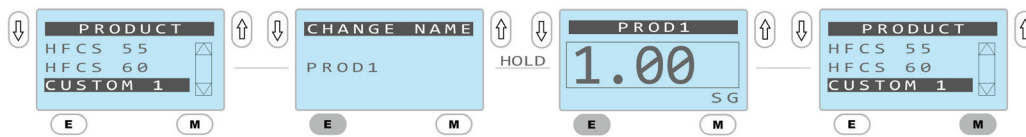

Up and down arrows increment characters and value. E moves to the next character and Long Hold E moves to the Value. Alpha numeric values and symbols may be used in the name.

7.6 – Dampening

The analog output can be digitally dampened to decrease the magnitude of large process fluctuations with a high frequency. The dampening value should be raised when the output is showing high frequency high magnitude fluctuations. The dampening factor can be adjusted from 0-10.



7.7 – mA Configuration

The mA configuration menu contains options to adjust the loop output to match the control system reading the signal, adjust the failure mode, and change the loop direction.

7.7.1 – mA Calibration

When a transmitter is added to a system for the first time a mA calibration should be performed to ensure the sensor's 4mA and 20mA points align with the control system in which it is installed. Because input cards are variable this will provide the best results and avoid programming an offset in the PLC.

The mA calibration requires the device to be installed in a control loop where the mA value may be read by observed by the operator and the display may also be accessed.

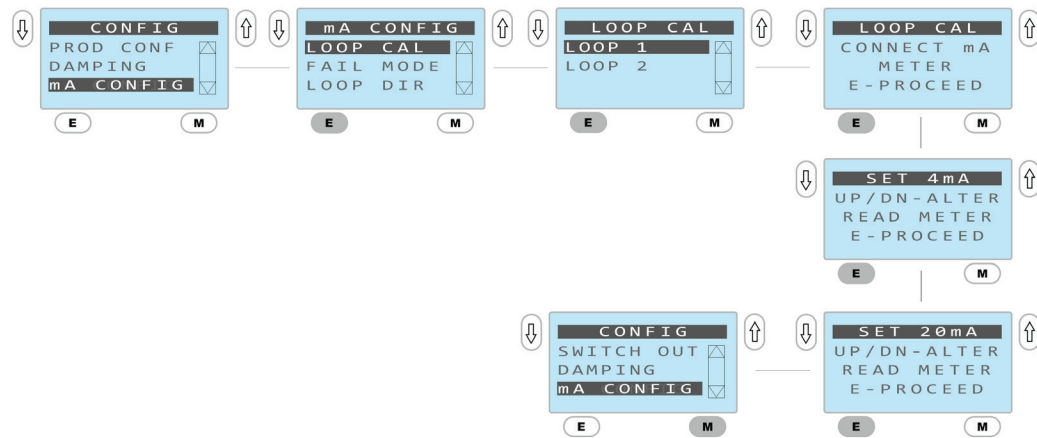

7.7.2 – Failure Mode Selection

The D3 may be set to fail low (3.8mA output) or fail high (20.2mA output) when a valid process variable cannot be output.

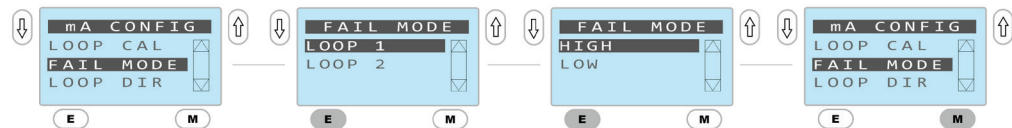

7.7.3 – Loop Direction

The loop direction may be reversed (20mA -4mA). This is accomplished as follows:

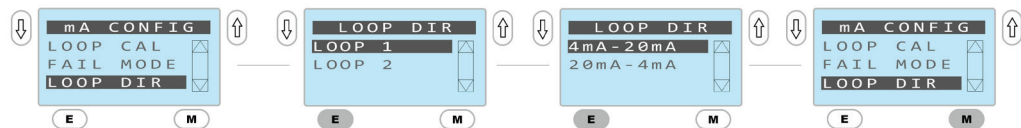

7.7.4 – Secondary Value Selection

The top or the bottom sensor may be selected for the secondary value:

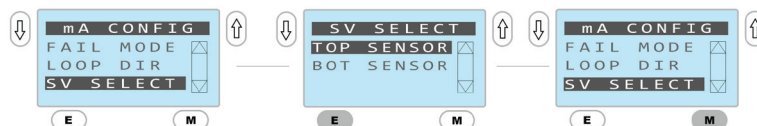

7.8 – Re-zero

The D3 transmitter is sensitive to both orientation and clamping forces during installation. It is important to re-zero the sensor after it has been installed. Additionally, if the diaphragm is dented or goes through a period of stress such as being steamed for the first time, it is important to zero the sensor.

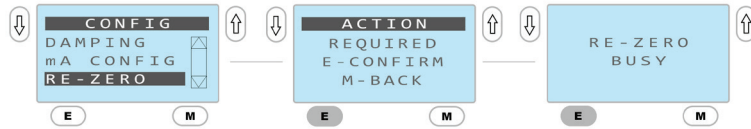

Note: Both sensors will be re-zeroed. Make sure both sensors are vented.

7.9 – Factory Reset

If at any time the owner decides to go back to factory default settings there is an option to do so. This will reset all values including units, ranges, alarms, tank and product data.

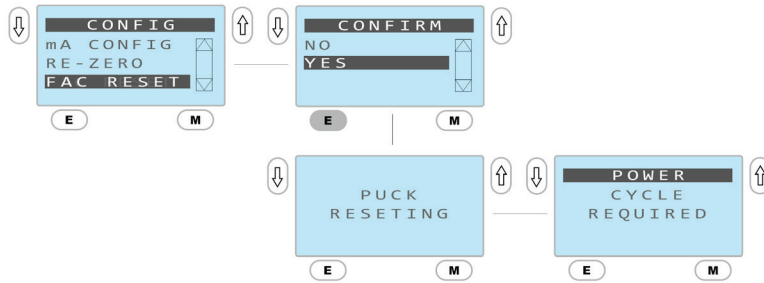

7.10 – Device Information

Through the device information screen the owner may access the following information:

Serial number, upper range limit (URL), lower range limit (LRL), device type, puck firmware revision, and sensor firmware revision

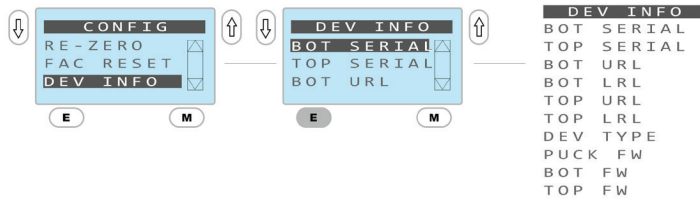

Section 8 - Maintenance/Diagnostics

Warning! Do not remove this sensor from the process while it is operating. Removal while the process is operating can contaminate the process and could cause human injury.

Warning: Before removing for service or calibration, ensure that residual product has been flushed from the line and that internal pressure has returned to atmospheric pressure.

Anderson electronic sensors require very little maintenance, if any. We suggest that the sensor be inspected at 6 month intervals to ensure that they are not being subjected to physically abuse, moisture entering the housing, and that the wiring is sound.

Caution: Do not open the sensor enclosure in wet or spray-down environments. Moisture ingress can cause premature electronics failure.

External cleaning instructions: The external surfaces of this sensor can be cleaned along with the equipment or piping system that it is installed on, using cleaning and disinfecting solutions designed for use on hygienic equipment.

The D3 is equipped with diagnostic routines that monitor the sensor's function. Should an error occur the diagnostic display will flash an error code and the output will go to the failure state specified by the user. Errors may be caused by a number of reasons ranging from failed electronic components to user configuration errors. The code appendix below indicates possible codes with actions that should be taken to correct the problem. Error codes may be cleared to facilitate subsequent menu changes, however the output will remain at the specified failure state until error is addressed and the unit repowered. Always record the error code before attempting to clear it.

The display code may be erased as follows:

- From home screen press down and hold for several seconds. Some error codes will not erase until problem is resolved – Sensor displays current process value.
- Power cycle by removing power for 10 seconds then reattach power.

Caution: Improper replacement of components during service can result in process leakage, reduced pressure rating, system cleanability issues, incorrect output signal, or error code(s).

8.1 - Error Codes

Error Code	Category	Customer Action
w100T	Warning: Incompatible Top Stem Range	Re-range top sensor to compatible stem range.
w100B	Warning: Incompatible Bottom Stem Range	Re-range bottom sensor to compatible stem range.
w101	Warning: Stem Type Changed	Re-range top and bottom sensor to compatible stem ranges.
w102	Warning: PV (Diff) Unit Changed	Reconfigure puck to required PV (Diff) unit. Reset error.
w103	Warning: PV (Diff) Over Pressure	Check Process. Diff value reached above Diff URV.
w103T	Warning: Top Stem Over Pressure	Check Process. Top stem exposed to pressure above top URV.
w103B	Warning: Bottom Stem Over Pressure	Check Process. Bottom stem exposed to pressure above bottom URV.
w104	Warning: Top Stem Under Pressure	Check Process. Diff value reached below Diff LRV.
w104T	Warning: PV (Diff) Under Pressure	Check Process. Top stem exposed to pressure below top LRV.
w104B	Warning: Bottom Stem Under Pressure	Check Process. Bottom stem exposed to pressure below bottom LRV.
e300T, e301T, e302T	Top Stem Data Corruption	Replace Top Stem.
e300B, e301B, e302B	Bottom Stem Data Corruption	Replace Bottom Stem.
e500T	Top Stem Not Connected	Check top stem ribbon cable connection to puck. Power cycle.
e500B	Bottom Stem Not Connected	Check bottom stem ribbon cable connection to puck. Power cycle.
e501T, e502T, e503T	Top Stem Data Corruption	Replace Top Stem.
e501B, e502B, e503B	Bottom Stem Data Corruption	Replace Bottom Stem.
e600	Puck Data Corruption	Factory restore. If error persists, replace puck.
w602	Puck Data Corruption. Factory Defaults Loaded.	Power cycle. Perform mA Config. Re-configure ranges, units, Loop2 Source. Re-zero. If error persists, replace puck.
e607	Puck Data Corruption. Puck Reset to Unconfigured State.	Power cycle. Perform mA Config. Re-configure ranges, units, Loop2 Source. Re-zero. If error persists, replace puck.
e701	Internal System Failure	Reset error and power cycle. Perform factory reset. If error persists, replace puck and stem.

Display Code	Category	Customer Action
TOP	Displaying Top Sensor Pressure	Hold UP button for 2 seconds and release to toggle to DIFF value.
BOTTOM	Displaying Bottom Sensor Pressure	Hold UP button for 2 seconds and release to toggle to DIFF value.

Feel free to contact Anderson Technical Services Department at 1-800-833-0081 for further assistance with troubleshooting.

Section 9 - Warranty and Return Statement

These products are sold by The Anderson Instrument Company (Anderson) under the warranties set forth in the following paragraphs. Such warranties are extended only with respect to a purchase of these products, as new merchandise, directly from Anderson or from an Anderson distributor, representative or reseller, and are extended only to the first buyer thereof who purchases them other than for the purpose of resale.

Warranty

These products are warranted to be free from functional defects in materials and workmanship at the time the products leave the Anderson factory and to conform at that time to the specifications set forth in the relevant Anderson instruction manual or manuals, sheet or sheets, for such products for a period of two years.

THERE ARE NO EXPRESSED OR IMPLIED WARRANTIES WHICH EXTEND BEYOND THE WARRANTIES HEREIN AND ABOVE SET FORTH. ANDERSON MAKES NO WARRANTY OF MERCHANTABILITY OR FITNESS FOR A PARTICULAR PURPOSE WITH RESPECT TO THE PRODUCTS.

Limitations

Anderson shall not be liable for any incidental damages, consequential damages, special damages, or any other damages, costs or expenses excepting only the cost or expense of repair or replacement as described above.

Products must be installed and maintained in accordance with Anderson instructions. Users are responsible for the suitability of the products to their application. There is no warranty against damage resulting from corrosion, misapplication, improper specifications or other operating condition beyond our control. Claims against carriers for damage in transit must be filed by the buyer.

This warranty is void if the purchaser uses non-factory approved replacement parts and supplies or if the purchaser attempts to repair the product themselves or through a third party without Anderson authorization.

Returns

Anderson's sole and exclusive obligation and buyer's sole and exclusive remedy under the above warranty is limited to repairing or replacing (at Anderson's option), free of charge, the products which are reported in writing to Anderson at its main office indicated below.

Anderson is to be advised of return requests during normal business hours and such returns are to include a statement of the observed deficiency. The buyer shall pre-pay shipping charges for products returned and Anderson or its representative shall pay for the return of the products to the buyer.

Approved returns should be sent to:

ANDERSON INSTRUMENT COMPANY INC.
ATT: REPAIR DEPARTMENT
156 AURIESVILLE ROAD
FULTONVILLE, NY 12072 USA



ANDERSON-NEGELE

ANDERSON INSTRUMENT CO., INC • 156 AURIESVILLE RD. • FULTONVILLE, NY 12072 • USA • 800-833-0081 • FAX 518-922-8997
ANDERSON INSTRUMENT CO. LP • 400 BRITANNIA RD. EAST, UNIT 1 • MISSISSAUGA, ONTARIO L4Z 1X9 • CANADA • 905-603-4358 • FAX 905-568-1652
NEGELE MESSTECHNIK GmbH (A Division of Anderson) • RAIFFEISENWEG 7 • D-87743 EGG A. D. GÜNZ • GERMANY • +49 (0) 8333/9204-0 • FAX +49 (0) 8333/9204-49

www.anderson-negele.com