

Instruction Manual



Anderson Instrument Co. Inc.
156 Auriesville Road
Fultonville, NY 12072
1-800-833-0081
www.anderson-negele.com

ANDERSON-NEGELE

Instrument Model Number _____

Instrument Serial Number _____

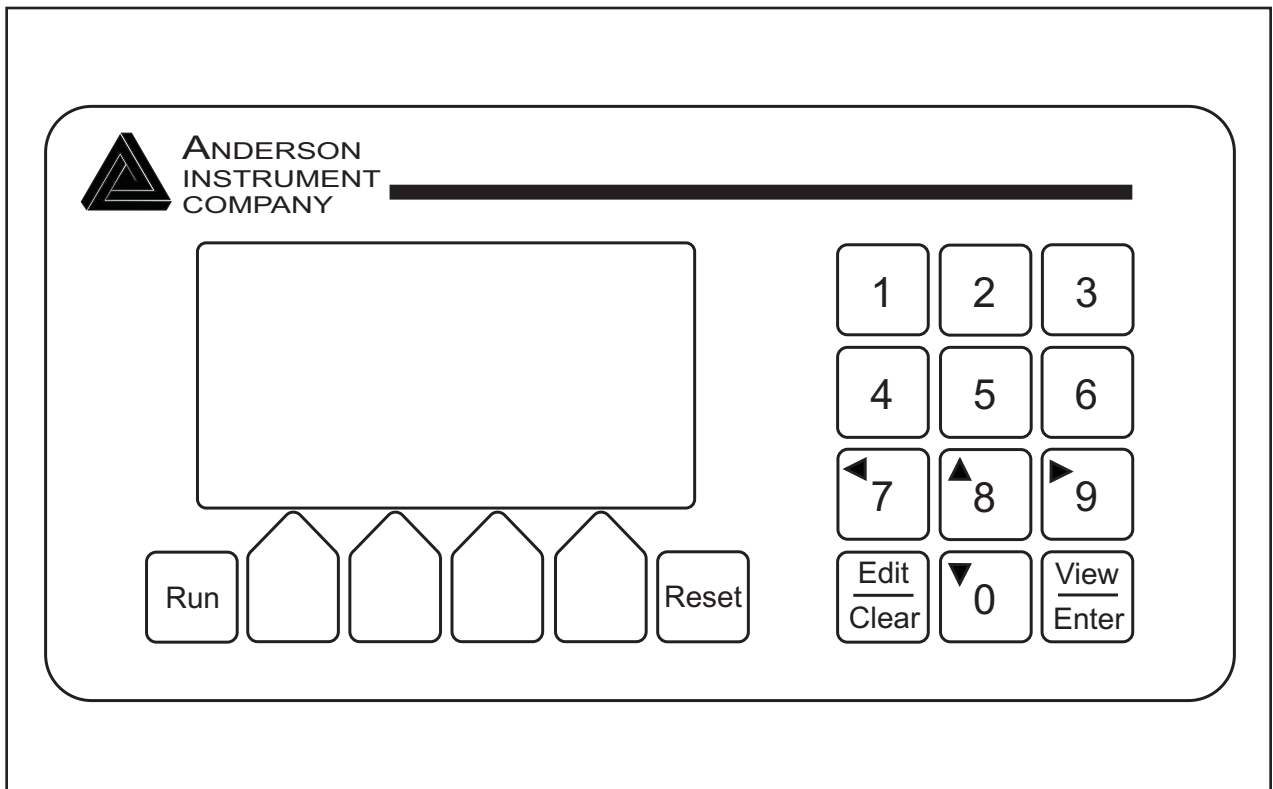

BC104 BATCH CONTROLLER

TABLE OF CONTENTS

SECTION 1 - GENERAL DESCRIPTION	3
1.1 BC104 DUAL PRESET BATCHING CONTROLLER	3
SECTION 2 - SPECIFICATIONS	4
SECTION 3 - INSTALLATION INSTRUCTIONS	6
3.1 GENERAL	6
SECTION 4 - WIRING	7
SECTION 5 - OPERATING FUNCTIONS	10
5.1 BC104 FRONT PANEL	10
5.2 KEYPAD	10
5.3 POWER-UP DISPLAY VALUE	11
5.4 TOTAL INDICATOR	11
5.5 TOTAL RESET	11
5.6 FLOW RATE INDICATOR	11
5.7 PROGRAM MODE	12
5.8 RUN MODE	12
5.9 BATCH DISPLAY	12
5.10 PRESET DISPLAY	12
SECTION 6 - OPERATING EXAMPLE	13
SECTION 7 - SCALE FACTOR	14
SECTION 8 - RATE FACTOR	16
SECTION 9 - BC104 PROGRAM EXAMPLE	18
SECTION 10 - FIELD ADJUSTMENT	20
10.1 SCALE FACTOR USING DIFFERENCE IN INDICATED AMOUNT	20
10.2 SCALE FACTOR USING PERCENTAGE OF ERROR	20
10.3 RATE FACTOR USING DIFFERENCE IN INDICATED AMOUNT	21
10.4 RATE FACTOR USING PERCENTAGE OF ERROR	21
SECTION 11 - TROUBLE-SHOOTING	22
11.1 GENERAL	22
SECTION 12 - WARRANTY AND RETURN STATEMENT	23

LIST OF FIGURES

FIG. 1	Panel Mounting Dimensions	6
FIG. 2	Wall Mount Enclosure for BC104	6
FIG. 3	Terminal Identifications	7
FIG. 4	Typical AC wiring schematic for standard batching application	8
FIG. 5	2 wire electromagnetic and mass flowmeters	8
FIG. 6	3 wire rotary piston and turbine flowmeters	9
FIG. 7	Remote command wiring	9
FIG. 8	BC104 Front Panel	10
FIG. 9	Power-up Display	11
FIG. 10	Reset Total Display	11
FIG. 11	Batch Display	12
FIG. 12	Preset Display	12
FIG. 13	Operating Example Batch Display	13
FIG. 14	Program Example Scale Factor Display	18
FIG. 15	Program Example Rate Factor Display	18
FIG. 16	Program Example Preset Display	19

SECTION 1 - GENERAL DESCRIPTION

1.1 BC104 DUAL PRESET BATCHING CONTROLLER

The BC104 Batch Controller has a 6-digit preset count with a running total and flow rate indicator. Two (2) Form C Relay Outputs provide two-stage shutdown. Other features include incoming count scaling, programmable decimal points, program lock-out, and independent reset, start, stop, and midcycle resume keys.

SECTION 2 - SPECIFICATIONS

POWER REQUIREMENTS:

AC Power: 85/265 VAC, 47 to 63 Hz, 20 VA; Isolation 2300 VAC

ENVIRONMENT:

Operating Temperature: 32° to 122°F (0° to 50°C)
Storage Temperature: -4° to 158°F (-20° to 70°C)
Operating Humidity: 0-85% RH Non-Condensing

PHYSICAL:

Case Dimensions: 5.33" W x 2.57" H x 2.79" D
(135.5mm W x 65.3mm H x 70.87mm D)
Stainless Enclosure Dimensions: 10.88" W x 8.75" H x 7.63" D
(276.4mm W x 222.3mm H x 193.8mm D)
Bezel Dimensions: 6.18" W x 3.42" H x 0.35" D
(157mm W x 87mm H x 9mm D)
Lip: 0.33" (8.5mm)
Panel Cut-Out Dimensions: 5.43+0.039" W x 2.68+0.028" H
(138+1mm W x 68+0.7 mm H, DIN)
Mounting Panel Thickness: 0.375" (9.5mm) maximum
Include front panel O ring will provide watertight seal

Weight: 1 Pound (0.45 Kg)
Enclosure Weight: 12.1 Pounds (5.493 Kg)
Display Type: 128 x 64 pixel graphic LCD with LED backlight
Character Size: 0.12" high, 21 characters per line, 6 lines maximum
0.24" high, 10 characters per line, 3 lines maximum
0.35" high, 7 characters per line, 2 lines maximum

Keys

Number: 18
Type: Membrane switches with tactile feedback

Counter

Count Range: 6 digits (0 to 999,999) with Rollover
Preset Range: 6 digits (0 to 999,999)
Count Modes: Count with Add and Subtract Inputs
Count with Up/Down Direction Input (Hardware doubling for above modes is provided)

INPUTS:

Control inputs

Number: 10
Impedance: 4.75k Ohms to +5 VDC
Thresholds: High 3.5 - 30 VDC; Low 0 - 1.0 VDC

Count inputs

The count inputs are designed to work with current sinking sensors (open-collector NPN transistor output) with or without passive pull-up resistor or contact closures to DC Common.

Number: 3 (including reset)
Thresholds: High 3.5-30 VDC; Low 0-1.5VDC, or 200 mVp-p to 50 V rms @ 26.9k Ohms (mag pickup)
Response: 140 Hz or 14 kHz for sinking, push-pull or mag pickup inputs 60 Hz or 6 kHz for sourcing only inputs
All frequencies based on 50-50 duty cycle
6 kHz maximum sustained count speed

Analog inputs

Number: 4
Type: (2) 4 - 20 mA and (2) 0 - 10 VDC
Accuracy: +0.5% FS and +200 PPM/°C
Impedance: 100 Ohms (current input), 1.27 Ohms (voltage input)
Overrange: 45 mA maximum (current input), 20 V maximum (voltage input)

OUTPUTS:

Power: 24 DC +15%, 100 mA maximum, short circuit protected
12 DC +10%, 75 mA maximum, short circuit protected

Relays

Number: 3 (Form C), 2 (Form A)
Contacts: 5A, 250VAC, 30 VDC
Isolation: 2300 VAC

Transistors

Number: 2
Type: NPN Darlington
Ratings: 150 mA maximum ON current, 30 VDC maximum OFF voltage

Analog

Number: 2, short circuit protected
Type: 4-20mA (<450 Ohms), 0-10V (>2500 Ohms)
Accuracy: +0.5% FS and +200 PPM/°C
Common Mode Voltage Rating: 250 VAC
Isolation: 2300 VAC

RS 232

Connector: DB-9S
Polarity: DCE
Baud Rate: 1200 - 19200

RS 485

Connector: 6 wire RJ-12 phone jack
Baud Rate: 1200 - 19200

DATA RETENTION:

Program Data

Type: Non-volatile
Duration: 100 Years, no batteries

Real Time Clock

Type: Capacitor
Charge Time: 3 Minutes
Retention: 1-5 Days

COUNT SCALE FACTOR:

Range: 6 Digits (0.00001 to 9.99999)

SECTION 3 - INSTALLATION INSTRUCTIONS

3.1 GENERAL

When mounting, the location selected must provide for adequate air circulation space around the unit. Avoid locating the unit near instruments and/or equipment that generates excessive heat. Do not locate the unit near high voltage lines, transformers, or motor starters

Figure 1 -- Panel Mounting Dimensions



WARNING - This device is an Open Type, Listed Process Control Equipment, and must be mounted in an overall enclosure.

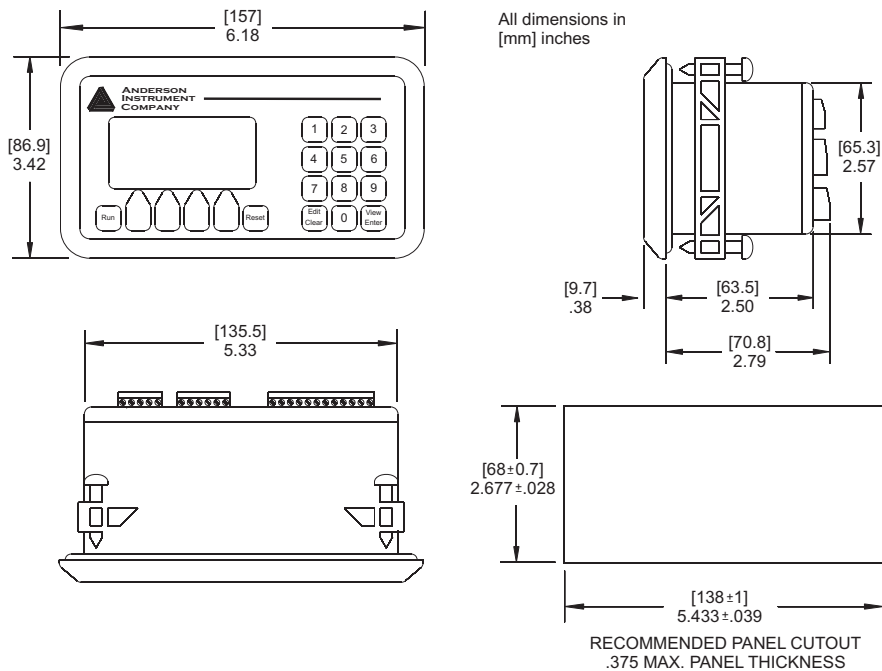
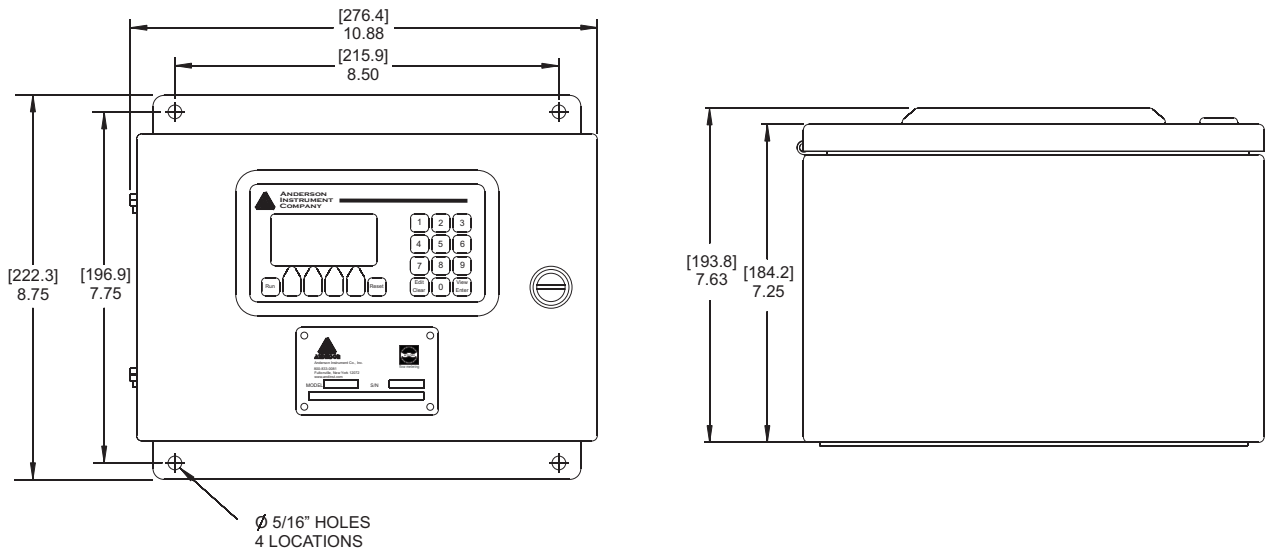

Figure 2 -- Wall Mount Enclosure for BC104

All dimensions in [mm] inches



SECTION 4 - WIRING



WARNING - Disconnect all power before wiring terminals. A safety hazard may exist if this precaution is not observed. Treat all power and output terminals as hazardous, since they may carry line voltage.

1. Do not connect power until all control wiring is complete.
2. Do not use machine power service for 120/240 VAC input power to the Control. A dedicated circuit is recommended. Unit is not fused, user must provide slow blow fuse as per figure 4.
3. Keep all signal cables as short as possible. This cable is to be shielded and is not to be bundled or routed with power carrying lines.
4. Before applying power to the equipment, recheck all wiring to insure proper connections.
5. When all wiring connections are completed, seal off all holes, conduit connections, and any other passages that could allow entry of moisture or contaminants to the Controller.

TERMINAL IDENTIFICATION

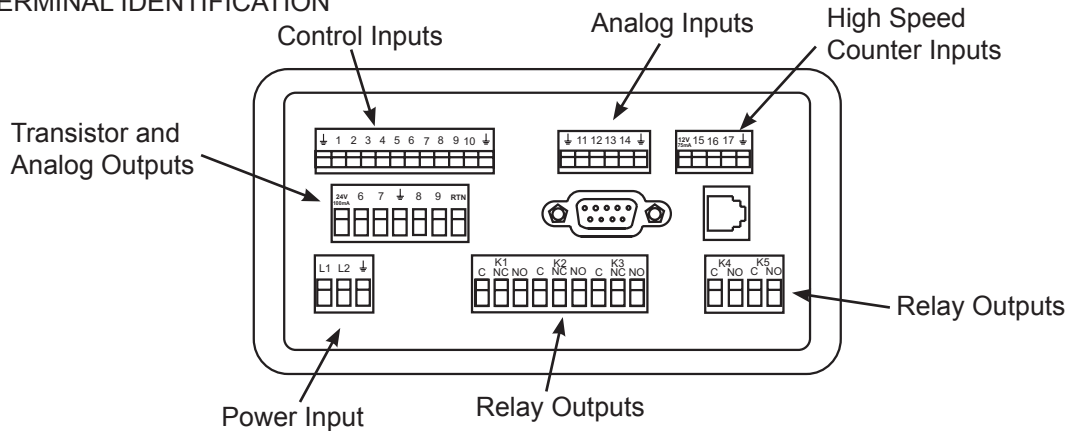

Control Inputs	
Gnd	Input DC Common
1	Start Input
2	Stop Input
3	Reset Input
4	NA
5	NA
6	NA
7	NA
8	NA
9	Inhibit
10	Program Enable
Gnd	Input DC Common
Analog Inputs	
Gnd	NA
11	NA
12	NA
13	NA
14	NA
Gnd	NA

High Speed Counter Inputs	
12V	+ 12 VDC Output (75 mA)
15	NA
16	Signal Input
17	NA
Gnd	Input Common
Transistor and Analog Outputs	
24V	+ 24 VDC Output (100 mA)
6	NA
7	NA
Gnd	Output DC Common
8	NA
9	NA
RTN	NA
Power Input	
L1	120/220 VAC
L2	120/220 VAC
Gnd	Safety Ground

Relay Outputs	
K1 C	Relay K1 Common
K1 NC	Relay K1 N.C.
K1 NO	Relay K1 N.O.
K2 C	Relay K2 Common
K2 NC	Relay K2 N.C.
K2 NO	Relay K2 N.O.
K3 C	NA
K3 NC	NA
K3 No	NA
Relay Outputs	
K4 C	NA
K4 NO	NA
K5 C	NA
K5 NO	NA

All inputs are activated when connected to DC Common. A wire jumper, mechanical contact, or NPN transistor can be used.

POWER CONNECTION AND RELAY DIAGRAM

Figure 4 -- Typical AC wiring schematic for standard batching applications

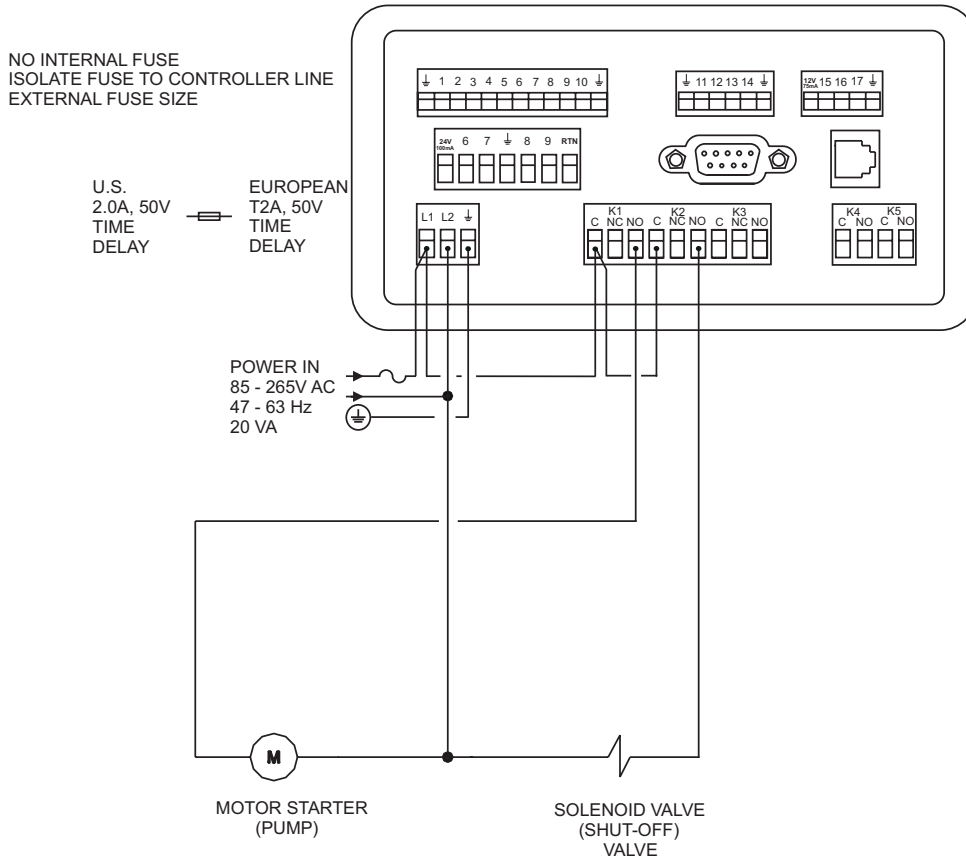

TYPICAL SIGNAL CONNECTION DIAGRAMS

Figure 5 – 2 wire electromagnetic and mass flowmeters

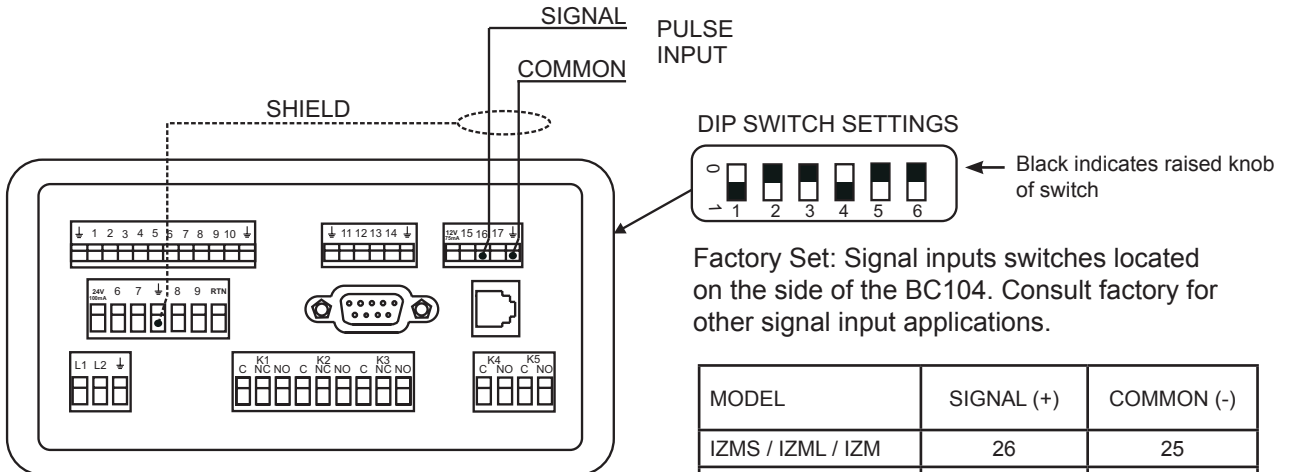

Factory Set: Signal inputs switches located on the side of the BC104. Consult factory for other signal input applications.

MODEL	SIGNAL (+)	COMMON (-)
IZMS / IZML / IZM	26	25
RFT9712	19	18
RFT9739	15	16
1700 / 2700	3	4

Figure 6 – 3 wire rotary piston and turbine flowmeters

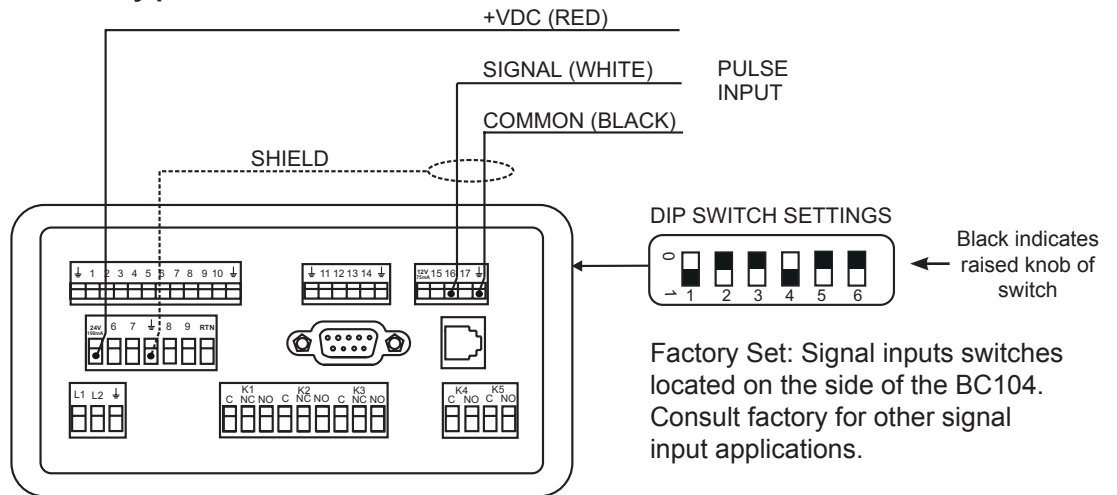
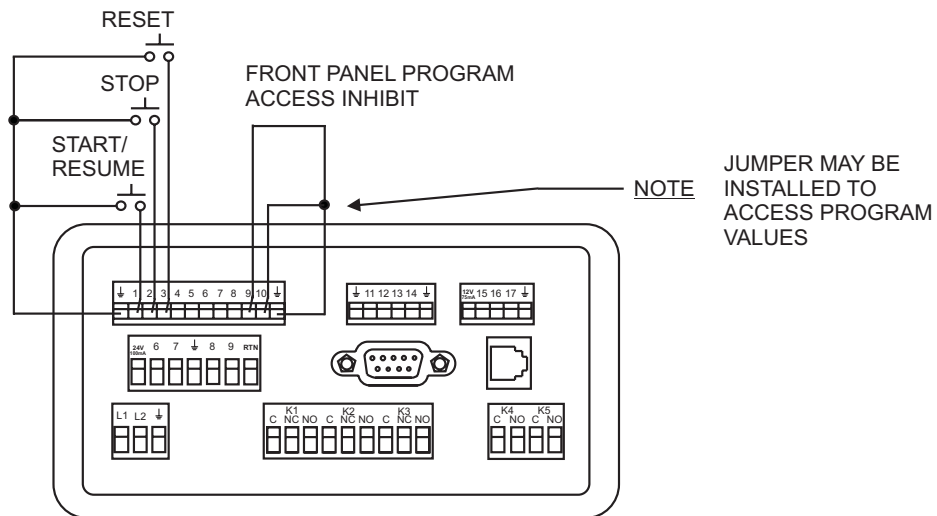

Figure 7 – Remote command wiring



SECTION 5 - OPERATING FUNCTIONS

5.1 BC104 FRONT PANEL

The front panel consists of the display and 18 keys.

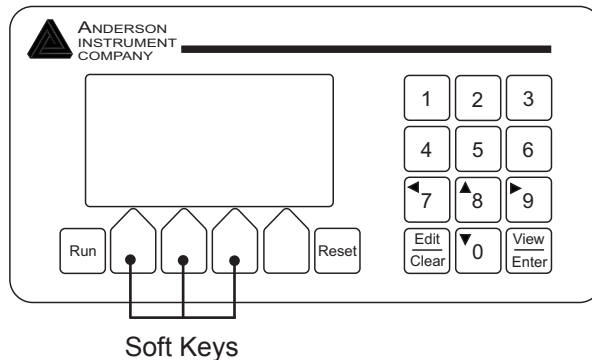

5.2 KEYPAD

The 18 keys on the front panel each perform no function, one function, or multiple functions, as follows:

- **Run** – has no function.
- **Soft keys** (the three pentagonal keys below the display) – these keys are used to select different screens in operate and program modes and to run a batch. They are defined by the third line of the display.
- **Stop** (the red pentagonal key below the display) – used to pause or end a batch cycle. Pressing the stop key while in a paused state will end a batch cycle.
- **Reset** – this key is used to reset the Main Counter to the preset value.
Note: DO NOT use the reset key when the batch is in a paused state. The paused batch count would be lost, and reset to the preset value.
- **1-0** – these keys are used to enter numeric information for presets or calibration factors. If the BC104 is not currently in the editing mode, the installer can program these keys to perform specific functions for the application.
- **1 & 3** – this combination of keys are used to reset the total while the batch cycle is in a completed state. Holding the 1 & 3 keys for 5 seconds will prompt a “RESET TOTAL” screen. Reset is acknowledged with “YES/NO” soft key prompts.
- **Edit/Clear** – this key is used to modify programmed values or preset value.
- **View/Enter** – the View key scrolls through the display screens that are viewable to the operator. The “Enter” key is used to terminate and enter calibration values or preset values.

5.3 POWER-UP DISPLAY VALUE

Upon power up, the BC104 will display the previously indicated Batch Count value. Pressing the Reset key will change the Batch Count value to the current Preset value. If power is lost during operation; preset value can be modified to reflect the power-up displayed value to complete the intended batch.

Total value will display from the second line upon power-up. Rate value can be viewed by pressing the “Rate” soft key.



5.4 TOTAL INDICATOR

The Anderson BC104 has a Total Indicator feature that operates simultaneously with the Count at all times.

The Total Indicator is displayed when selected from the Rate indicator using the “TOTAL” soft key.

5.5 TOTAL RESET

The Total Indicator is reset independently from the Count Indicator by pressing and holding keys 1 & 3 for 5 seconds. The display will then prompt a “RESET TOTAL?” message. Selecting the “YES” or “NO” soft keys will acknowledge this message prompt.

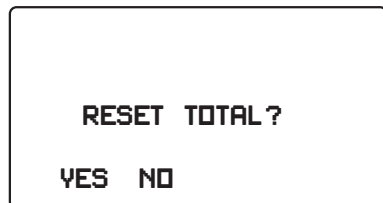

5.6 FLOW RATE INDICATOR

The Anderson BC104 has a Flow Rate Indicator feature that operates simultaneously with the Count at all times.

The Rate Indicator is displayed when selected from the Total indicator using the “RATE” soft key.

5.7 PROGRAM MODE

Anderson can preprogram your BC104 when requested at time of order. Program values can be accessed from the keypad by pressing the Stop soft key then holding keys 2 & 4 for 4 seconds. Front panel access can be disabled by installing a jumper between input terminals 9 and ground. Program can also be access by installed a jumper between input terminals 10 and ground (See page 11 figure 7).

5.8 RUN MODE

Once the BC104 is wired and programmed for a specific application, it is ready for use. In general, the operator may be expected to view data on the display, and to enter different batch preset values. This section of the manual explains these functions.

5.9 BATCH DISPLAY

The display normally shows the batch count on the top line, and "Total, or Rate" on the second line while in operation. The third line shows controller action and other selectable display screens. Selecting the "PRST" marked soft key will show batch preset screen. Preset changes can be made from this screen using the Edit/Clear key. The second line on the preset screen shows current relay status with an (on/off) indication. While in operation the current batch count is indicated on the third line of the preset screen.



5.10 PRESET DISPLAY

A cursor resides in the right hand column of the display whenever a change is made using the Edit/Clear key . The cursor is indicated by the first character flashing between the programmed character for that line, and an underscore (_). Values may be entered in the order displayed using the numeric keypad, and acknowledged with pressing the Enter key. Pressing the Edit/Clear key a second time will move the cursor to the next parameter when in the program mode. If the cursor is not moved in 8 seconds, it will time out.

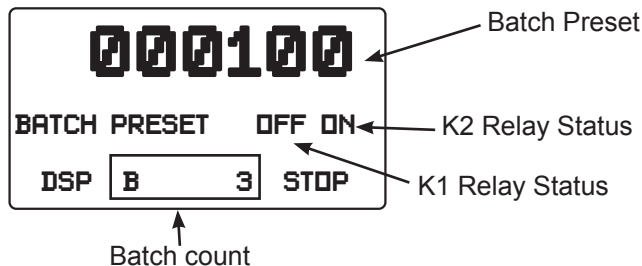

SECTION 6 - OPERATING EXAMPLE

Attention: Do not attempt the following steps if the batch controller is not programmed.

OBJECTIVE:

PROGRAM "369.0" BATCH PRESET

(STEPS 1-5 BELOW)

START, PAUSE, AND RESUME BATCH CYCLE:

(STEPS 6-8 BELOW)

KEYSTROKE

RESULT

- | | |
|--|---|
| <ol style="list-style-type: none"> 1) Press "PRST" soft key 2) Press Edit/Clear key* 3) Enter desired value 4) Press the View/Enter key 5) Press "DSP" soft key** | <p>Batch Preset screen displayed
 Prompts the edit cursor on the batch preset value
 New value displayed
 Display blinks once
 Displays current value on main counter</p> |
|--|---|

START BATCH CYCLE.

- | | |
|---|--|
| <ol style="list-style-type: none"> 6) Press Reset key 7) Press "START" soft key 8) Press "STOP" soft key 9) Press "RESUME" soft key | <p>Displays modified preset value
 Starts batch cycle. Preset will count-down to zero.
 Pauses batch cycle
 Resumes paused batch cycle</p> |
|---|--|

If the next batch requires the same "369.0" preset amount as previously delivered, simply press the Reset key, then "Start" soft key.

Figure 14 – Keystroke example



* Edit cursor will time out if not moved in 8 seconds.

** If clearing total prior to starting the batch; press and hold keys 1 & 3 for 5 seconds. Select "YES" soft key to acknowledge reset.

NOTE: Examine the ascending Total to compare the delivered quantity with the selected preset amount. If the values are not identical, adjust Level 1 value for the displayed error. An over-fill will require an increase of the Level 1 value by the amount displayed. An under-fill will require a decrease of the Level 1 value by the amount displayed.

SECTION 7 - SCALE FACTOR

Typically, flowmeters generate different numbers of pulses for each unit of measurement. This number is usually expressed in pulses per gallon, which we call the "K-Factor." Additionally, the number of pulses per unit normally does not correspond to common engineering units. Therefore, the Scale Factor is a number that converts the unscaled pulses of a flowmeter into the desired engineering unit of your choice, such as gallons, tenths of gallons, liters, etc.

CALCULATIONS

The Scale Factor to be entered into the Counter is easily calculated by using this formula:

$$\text{Scale Factor} = \frac{1 \text{ (Unit of Measure)}}{\text{K Factor}}$$

SCALE FACTOR CALCULATION EXAMPLES

EXAMPLE 1:

A flowmeter might produce 788.5 pulses per gallon. If the Count is to display in "Whole Gallons," calculate as follows:

$$\text{Scale Factor} = \frac{1(1)}{788.5} = 0.00127$$

The Scale Factor number 0.00127 would then be entered from the count display in program mode. Use the following sequence to enter Scale Factor 0.00127.

Edit/Clear>-0-0-0-1-2-7->View/Enter>(Remove jumper if used or push "STOP" soft key

EXAMPLE 2:

If you desire "Tenths of Gallons" display, using 788.5 as the K-Factor, the Scale Factor would be calculated as follows:

$$\text{Scale Factor} = \frac{1(10)}{788.5} = 0.01268$$

Note that in this case, the decimal point on the Controller should be placed one place to the left. Use the following sequence to enter Scale Factor 0.01268

Edit/Clear>0-0-1-2-6-8>View/Enter

Program Count and Total decimal point one place to the left by changing the "Total DP" to 1.

Edit/Clear>Edit/Clear>1>View/Enter>(Remove jumper if used or push "STOP" soft key

EXAMPLE 3:

Using the K-Factor of 788.5, calculate for "Whole Liter" display.

$$\text{Scale Factor} = \frac{1(1)}{788.5} = 0.00126 \times 3.785 = 0.00480$$

Use the following sequence to enter Scale Factor 0.00480.

Edit/Clear>-0-0-0-4-8-0->View/Enter>(Remove jumper if used or push "STOP" soft key

EXAMPLE 4:

Using 788.5 as the K-Factor, calculate a Scale Factor for "Whole Pound" display using milk at 8.6 Pounds Per Gallon.

$$\text{Scale Factor} = \frac{1(1)}{788.5} = 0.00126 \times 8.6 = 0.01090$$

Use the following sequence to enter Scale Factor 0.01090.

Edit/Clear>-0-0-1-0-9-0->View/Enter>(Remove jumper if used or push "STOP" soft key

SECTION 8 - RATE FACTOR

The Rate Factor is a number that is used to set up the Engineering Unit for display. Whole seconds are used as the base time unit for programming the Rate Factor.

FORMULA:

$$\text{Rate Factor} = \frac{\text{Number of Seconds Per Displayed Time Unit} \times \text{Decimal Point Number}}{\text{K Factor}}$$

DESCRIPTIONS:

Seconds Per Time Unit: Units Per Second = 1
 Units Per Minute = 60
 Units Per Hour = 3600

Decimal Point Number: Number determined by decimal point location, used for rate factor calculation. Refer to Decimal Point Number shown on the table below.

DECIMAL POINT:

Decide at which location on the Count Display the decimal point should be located when the Rate Value is displayed. Then refer to the following table and enter the value for the Rate DP in program mode.

Rate DP	Decimal Point Location	Decimal Point Number
0	XXXXX. (NONE)	1
1	XXXX.X	10
2	XXX.XX	100
3	XX.XXX	1000
4	X.XXXX	10000

EXAMPLE 1:

Program Rate Factor to display in “whole gallons per minute.”

Time Unit: Minute = 60 Seconds
 Decimal Point Number: 1
 K Factor: 10 Pulses Per Gallon

$$\text{Rate Factor} = \frac{60 \times 1}{1} = 60.00$$

The Rate Factor number 60.00 would then be entered from the rate display in program mode. Use the following sequence to enter Rate Factor 60.00.

“RATE” soft key>Edit/Clear>6-0-0-0>View/Enter>Edit/Clear>Edit/Clear>0>View/Enter>(Remove jumper if used or push “STOP” soft key

EXAMPLE 2:

Program Rate Factor to display in “tenths of gallons per minute.”

Time Unit: Minute = 60 Seconds
 Decimal Point Number: 10
 K Factor: 30.30 Pulses Per Gallon

$$\text{Rate Factor} = \frac{60 \times 10}{30.30} = 19.80$$

Edit/Clear>1-9-8-0>View/Enter>Edit/Clear>Edit/Clear>1>View/Enter>(Remove jumper if used or push “STOP” soft key

EXAMPLE 3:

Program Rate Factor to display in “whole pounds per hour”.

Time Unit: Hour = 3600 Seconds
 Decimal Point Number: 1
 K Factor: 1 Pulse Per Pound

$$\text{Rate Factor} = \frac{3600 \times 1}{1} = 3600$$

Edit/Clear>3-6-0-0>View/Enter>Edit/Clear>Edit/Clear>0>View/Enter>(Remove jumper if used or push “STOP” soft key

SECTION 9 - BC104 PROGRAM EXAMPLE

- A. Meter K-Factor (normally expressed in pulses per gallon). The K-Factor is necessary for the Scale Factor calculation.
- B. Count and Total Display, decide on Engineering Unit (gallons, liters, pounds, etc.) and how it is to be incremented (whole units, tenths of units, etc.).
- C. Flow Rate Display, increments per unit.
- D. Level 1 value (pump shut-down, product slow-down).
- E. Preset amount, amount to be delivered (shut-off value).

EXAMPLE:

- A. Meter K-Factor = 30.30 Pulses Per Gallon
- B. Count and Total to display tenths of gallons
- C. Flow Rate to display whole gallons per minute
- D. Level 1 value: 1.0 Gallon
- E. Preset Amount: 100.0 Gallons

PROGRAMMING STEPS USING EXAMPLE ABOVE:

- 1. Calculate the Scale Factor for tenths of gallons.

$$\text{Scale Factor} = (1 \times 10)/(30.30) = 0.33003$$

See "Scale Factors" in this manual.

- 2. Access Program Mode (See Page 1 2)

- 3. Scale Factor entry sequence:

Edit/Clear>0-3-3-0-0-3>View/Enter

- 4. Program Count and Total decimal point one place to the left (tenth gallon display). See "Scale Factors: Example 2".

- 5. Count/Total Decimal Point entry sequence:

Edit/Clear>Edit/Clear>1>View/Enter

SCL Fctr	0.33003
Total DP	1
CNT RATE PRST	

- 6. Rate Factor entry sequence:

"RATE" soft key>Edit/Clear>6-0-0-0>View/Enter

See "Rate Factor" in this manual.

Rate Fctr	60.00
Rate DP	0
CNT RATE PRST	

7. Program 100.0 in Preset, entry sequence:
"PRST" soft key>Edit/Clear>1-0-0-0>View/Enter

8. Program 1.0 in PREWARN. Entry sequence:
Edit/Clear>Edit/Clear>1-0>View/Enter

Preset	000100.0	
PREWARN	1.0	
CNT	RATE	PRST

9. Remove program jumper or press the Stop soft key.
This completes the programming procedure. A batch cycle can now be run. Press the View/Enter key. Press Reset>"Start" soft key. (This will initiate a batch cycle for 100 gallons using the example above.)

SECTION 10 - FIELD ADJUSTMENT

10.1 SCALE FACTOR USING DIFFERENCE IN INDICATED AMOUNT

Occasionally, it is necessary to field adjust Scaling Factors to account for differing product viscosities or for wear in the meter. The procedure is displayed in the examples below.

EXAMPLE: "METER OVER-READS"

Meter reads 452 gallons. It should have been 450 gallons.
The old Scale Factor = 0.01260.

$$\begin{aligned} \text{New Scale Factor} &= \text{Old Scale Factor} \times \frac{\text{Known Amount}}{\text{Amount Read}} \\ &= 0.01260 \times 450/452 \\ &= 0.01254 \end{aligned}$$

EXAMPLE: "METER UNDER-READS"

Meter reads 98.7 gallons. It should have been 100 gallons.
The old Scale Factor = 0.01260

$$\begin{aligned} \text{New Scale Factor} &= \text{Old Scale Factor} \times \frac{\text{Known Amount}}{\text{Amount Read}} \\ &= 0.01260 \times 100/98.7 \\ &= 0.01276 \end{aligned}$$

10.2 SCALE FACTOR USING PERCENTAGE OF ERROR

EXAMPLE:

If meter over-registers by 0.4%, reduce the Scale Factor by 0.4%.
Old Scale Factor = 0.01260.

$$\begin{aligned} \text{New Scale Factor} &= \text{Old Scale Factor} \times 1 \pm \text{Percentage of Error} \\ &= 0.01260 \times (1 - 0.4\%) \\ &0.01260 \times 0.996 = 0.01254 \\ &= 0.01254 \end{aligned}$$

If meter under-registers by 1.3%, increase the Scale Factor by 1.3%.
Old Scale Factor = 0.01260.

$$\begin{aligned} \text{New Scale Factor} &= \text{Old Scale Factor} \times 1 \pm \text{Percentage of Error} \\ &= 0.01260 \times (1 + 1.3\%) \\ &0.01260 \times 1.013 = 0.01276 \\ &= 0.01276 \end{aligned}$$

10.3 RATE FACTOR USING DIFFERENCE IN INDICATED AMOUNT

Field adjustment of the BC104 rate factor should be performed in conjunction with scale factor adjustment. The procedure is displayed in the examples below.

EXAMPLE: "METER OVER-READS"

Meter reads 102 gallons per minute. It should have been 100 gallons per minute.
The old Rate Factor = 19.80.

$$\begin{aligned} \text{New Rate Factor} &= \text{Old Rate Factor} \times \frac{\text{Known Rate Value}}{\text{Indicated Rate}} \\ &= 19.80 \times 100/102 \\ &= 19.41 \end{aligned}$$

EXAMPLE: "METER UNDER-READS"

Meter reads 98 gallons per minute. It should have been 100 gallons per minute.
The old Rate Factor = 19.80

$$\begin{aligned} \text{New Rate Factor} &= \text{Old Rate Factor} \times \frac{\text{Known Rate Value}}{\text{Indicated Rate}} \\ &= 19.80 \times 100/98 \\ &= 20.20 \end{aligned}$$

10.4 RATE FACTOR USING PERCENTAGE OF ERROR

EXAMPLE:

If meter over-registers by 0.4%, reduce the Rate Factor by 0.4%.
Old Rate Factor = 19.80.

$$\begin{aligned} \text{New Rate Factor} &= \text{Old Rate Factor} \times 1 \pm \text{Percentage of Error} \\ &= 19.80 \times (1 - 0.4\%) \\ &19.80 \times 0.996 = 19.72 \\ &= 19.72 \end{aligned}$$

If meter under-registers by 1.3%, increase the Rate Factor by 1.3%.
Old Rate Factor = 19.80.

$$\begin{aligned} \text{New Rate Factor} &= \text{Old Rate Factor} \times 1 \pm \text{Percentage of Error} \\ &= 19.80 \times (1 + 1.3\%) \\ &19.80 \times 1.013 = 20.03 \\ &= 20.03 \end{aligned}$$

SECTION 11 - TROUBLE-SHOOTING

11.1 GENERAL

Most problems encountered when applying the Controller are due to, errors in the AC power wiring, and/or the flowmeter signal wiring connections.

PROBLEM	POSSIBLE CAUSE
Display does not light when AC power is turned on	Check wiring, fuses and primary AC power source.
Counter does not increment or decrement	Check signal wiring Check flowmeter and/or pick-up probe.
Counter does not display correct units	Check Scale Factor.
Counter counts past "0" without completing batch	Check the "PREWARN" value in program mode. The "PREWARN" should not exceed the "Preset" value.
Counter accumulates too many counts	"Electrical Noise." Check signal wiring installation to insure they are not bundled with AC power wiring. Make sure all signal cables are shielded. Check for extreme vibration at the pick-up probe or sensor. Check Scale Factor. Check for loose signal wires.
Relays do not energize	Check relay status on "PRST". See page 12.
Rate Indicator displays incorrect units	Check Rate Factor.

Note: Please contact the factory at 1-800-833-0081 for additional troubleshooting assistance.

SECTION 12 - WARRANTY AND RETURN STATEMENT

These products are sold by The Anderson Instrument Company (Anderson) under the warranties set forth in the following paragraphs. Such warranties are extended only with respect to a purchase of these products, as new merchandise, directly from Anderson or from an Anderson distributor, representative or reseller, and are extended only to the first buyer thereof who purchases them other than for the purpose of resale.

Warranty

These products are warranted to be free from functional defects in materials and workmanship at the time the products leave the Anderson factory and to conform at that time to the specifications set forth in the relevant Anderson instruction manual or manuals, sheet or sheets, for such products for a period of one year.

THERE ARE NO EXPRESSED OR IMPLIED WARRANTIES WHICH EXTEND BEYOND THE WARRANTIES HEREIN AND ABOVE SET FORTH. ANDERSON MAKES NO WARRANTY OF MERCHANTABILITY OR FITNESS FOR A PARTICULAR PURPOSE WITH RESPECT TO THE PRODUCTS.

Limitations

Anderson shall not be liable for any incidental damages, consequential damages, special damages, or any other damages, costs or expenses excepting only the cost or expense of repair or replacement as described above.

Products must be installed and maintained in accordance with Anderson instructions. Users are responsible for the suitability of the products to their application. There is no warranty against damage resulting from corrosion, misapplication, improper specifications or other operating condition beyond our control. Claims against carriers for damage in transit must be filed by the buyer.

This warranty is void if the purchaser uses non-factory approved replacement parts and supplies or if the purchaser attempts to repair the product themselves or through a third party without Anderson authorization.

Returns

Anderson's sole and exclusive obligation and buyer's sole and exclusive remedy under the above warranty is limited to repairing or replacing (at Anderson's option), free of charge, the products which are reported in writing to Anderson at its main office indicated below.

Anderson is to be advised of return requests during normal business hours and such returns are to include a statement of the observed deficiency. The buyer shall pre-pay shipping charges for products returned and Anderson or its representative shall pay for the return of the products to the buyer.

Approved returns should be sent to: ANDERSON INSTRUMENT COMPANY INC.
156 AURIESVILLE ROAD
FULTONVILLE, NY 12072 USA

ATT: REPAIR DEPARTMENT



ANDERSON-NEGELE

ANDERSON INSTRUMENT CO., INC • 156 AURIESVILLE RD. • FULTONVILLE, NY 12072 • USA • 800-833-0081 • FAX 518-922-8997
ANDERSON INSTRUMENT CO. LP • 400 BRITANNIA RD. EAST, UNIT 1 • MISSISSAUGA, ONTARIO L4Z 1X9 • CANADA • 905-603-4358 • FAX 905-568-1652
NEGELE MESSTECHNIK GmbH • RAIFFEISENWEG 7 • D-87743 EGG A. D. GÜNZ • GERMANY • +49 (0) 8333/9204-0 • FAX +49 (0) 8333/9204-49

www.anderson-negele.com