



ANDERSON-NEGELE

# Technical Bulletin

## AJ-300 Series Circular Chart Recorder For Use in HTST Meter Based Timing - Setup and Configuration -

The Anderson AJ-300 Series Circular Chart Recorder and Recording Controller may be utilized in Meter Based Timing Systems (MBTS). As such, these instruments are required to meet the applicable criteria of the Pasteurized Milk Ordinance. The following details illustrate the proper configuration and programming for this application

### Model Number:

All units configured for MBTS should be verified as being equipped with a Sealable Chart Plate, in addition to an Event Pen. A "03" will appear at the end of the model number matrix. Model number matrix appears on a sticker located on the case lip, visible with door open.

Typical matrix number (X denotes options): AJ3XXX0XXXX02X03

In addition, rotation of circular chart shall be 12 hours for one full rotation

### Adjustment of High Flow and Loss-Of-Signal alarm setpoints:

These setpoints are pre-configured to provide fail-safe actuation of the Flow Diversion Valve, as well as controlling the Event Pen Action

Flowrate	Relay Action	Event Pen Position
Below Loss-Of-Signal Setpoint	RLY-A Open RLY-B Closed	Inward
Above Loss-Of-Signal Setpoint / Below High Flow	RLY-A Closed RLY-B Closed	Outward
Above High Flow	RLY-A Closed RLY-B Open	Inward

The Recorder will be wired so that the Flow Diversion Valve is energized ONLY when RLY-A AND RLY-B are closed, and all other criteria are met.

Process Alarm Setpoint 1 - Loss-Of-Signal (RLY-A)  
Process ALarm Setpoint 2 - High Flow Alarm (RLY-B)

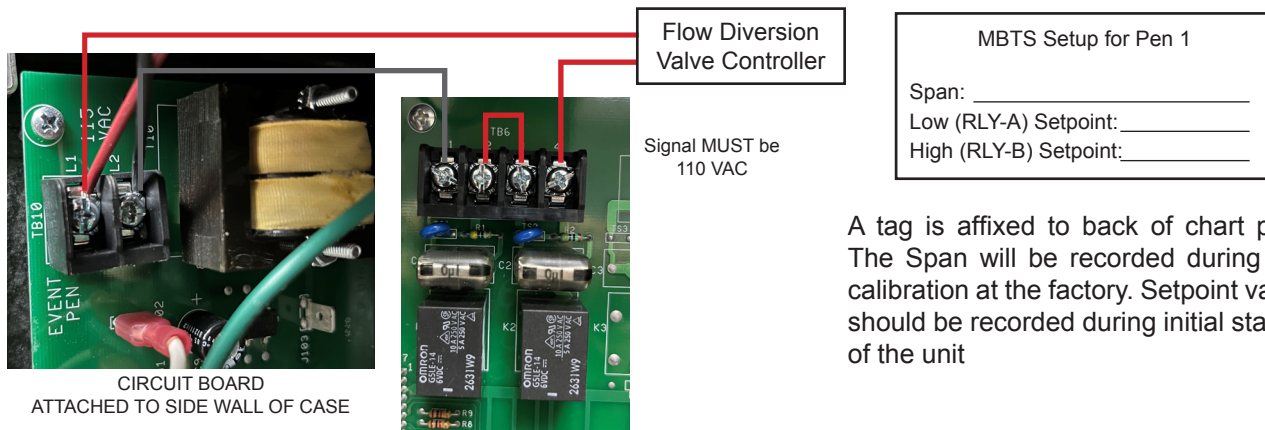

A tag is affixed to back of chart plate. The Span will be recorded during final calibration at the factory. Setpoint values should be recorded during initial start-up of the unit

---

## Checking the Setpoint Values

Break and remove the *Health Authority Wire Seal* on the chart plate. Loosen the chart plate screws, and pivot the chart plate open



Post A

Post B

Post A: Protrudes through chart plate when chart plate is in closed position. Drilled to accept Health Authority Wire Seal

Post B: Attached to chart plate. Drilled to accept Health Authority Wire Seal

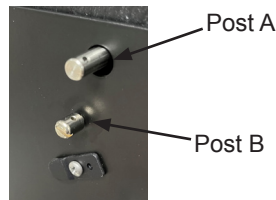

Post A

Post B

## Recorder - Model Number Begins with: AJ31

Note: If menu option not visible, refer to section 3-1 Enable Mode Configuration Procedure to activate.

Press and release the SCROLL key until ASet is displayed in the lower **LEFT** display, then press **DOWN** key, Press the **SCROLL** key to advance the display through the parameters and their values. After all selections have been made, press the **UP** key while PAL1 or PAL2 is displayed (may be lower right window if two pen unit) to exit the view mode.

PAL1 = RLY-A = Loss-Of-Signal Setpoint Value

PAL2 = RLY-B = High Flow Setpoint Value

## Recorder - Model Number Begins with: AJ32

Note: If menu option not visible, refer to section 3-3 Enable Mode Configuration Procedure to activate.

Press and release the **SCROLL** key until tunE is displayed in the lower Left display, then press the **DOWN** key. Press the **SCROLL** key to advance the display through the parameters and their values. After all selections have been made, press the **UP** key when **Pb1** (or another parameter code is displayed to exit the view mode.

PAL1 = RLY-A = Loss of Signal Setpoint Value

PAL2 = RLY-B = High Flow Setpoint Value

## Changes to programmed values:

If changes to any programmed values are required, it will be necessary to re-position the program jumper from the LOCK position, to the PROGRAM position.

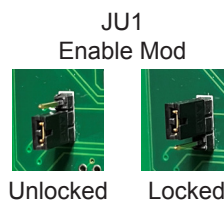

Unlocked

Locked