



G A U G E S  
T H E R M O M E T E R S  
T R A N S M I T T E R S  
R E C O R D E R S  
C O N T R O L L E R S  
L I Q U I D L E V E L S Y S T E M S  
R T D S

**ONE AND TWO PEN CIRCULAR CHART RECORDER**

# ACR 710

Installation, Wiring, Operation Manual

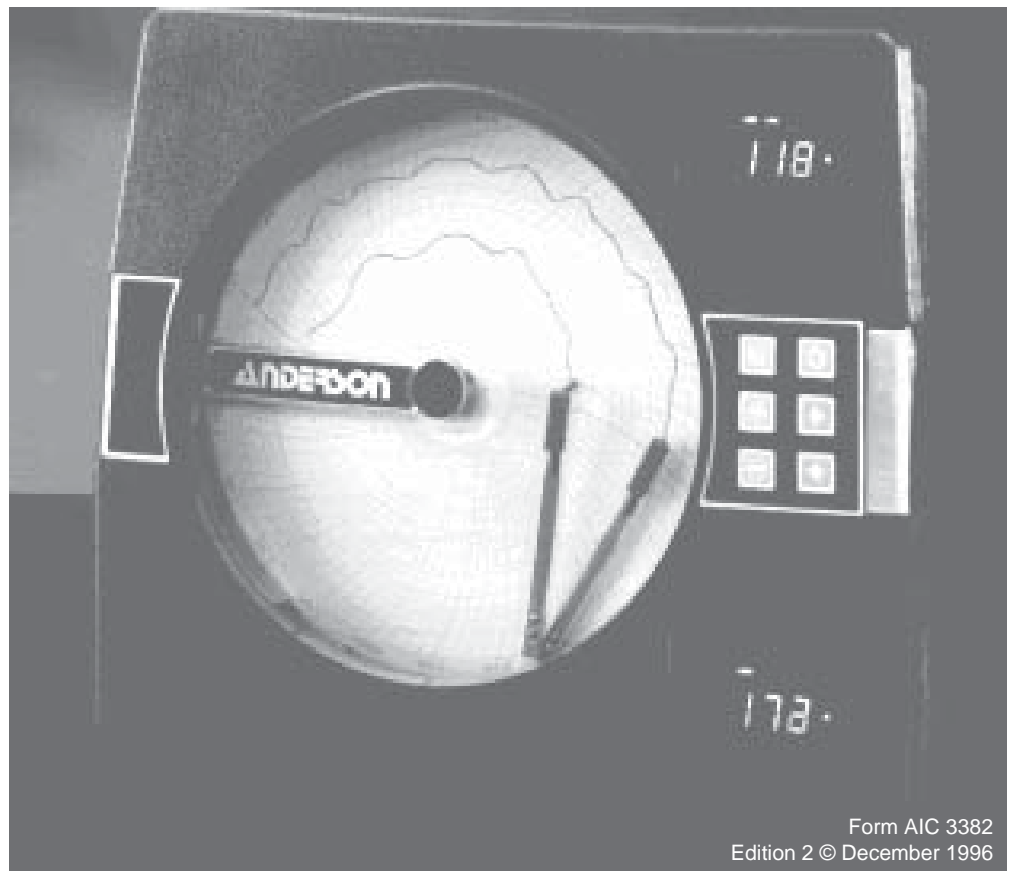

Form AIC 3382  
Edition 2 © December 1996

---

# Would you like information on our other products?

**Make a copy of this page, check next to the products you are interested in and fax it to us at 1-518-922-8997 or just call us at 1-800-833-0081**

**GAUGES**  
 **THERMOMETERS**  
 **TRANSMITTERS**  
 **RTDS**

**RECORDERS**  
 **CONTROLLERS**  
 **LIQUID LEVEL SYSTEMS**

---

Your Name

---

Company Name

---

Street Address

---

City, State, Zip/ Postal Code, Country, and Telephone Number

*Request form from ACR 710 Manual*

---

# TABLE OF CONTENTS

## SECTION 1 - GENERAL

1.1 Product Description

5

## SECTION 2 - INSTALLATION & WIRING

2.1 Installation & Wiring

7

2.2 Unpacking

7

2.3 Location

7

2.4 Mounting

7

2.5 Preparation for Wiring

8

2.6 Wiring Connections

13

## SECTION 3 - CONFIGURATION

3.1 Configuration (Set Up)

18

3.2 Configuration/Jumper Positioning

19

3.3 Operation Summary

19

3.4 Start up Procedure

20

3.5 Front Panel Operation

21

## SECTION 4 - SERVICE

4.1 Service

33

4.2 Changing Charts

33

4.3 Changing Pens

33

4.4 Calibration

34

4.5 Test Mode

39

4.6 Troubleshooting and Diagnostics

43

## APPENDICES

A - Board Layouts

A-1 Processor Board

50

A-2 SPST Relay/SSR Driver Output Board

51

A-3 SPDT Relay/SSR Driver Output Board

52

A-4 Current Output Board

53

B - Glossary

54

C - Model Number Hardware Matrix Details

55

D - Specifications

56

E - Software Record/Reference Sheet

59

Warranty

Inside back page

---

## FIGURES & TABLES

Figure 1-1	Recorder Description	5
Figure 1-2	Recorder Display	6
Figure 2-1	Installation Panel Dimensions Conduit Opening Locations	8
Figure 2-2	Noise Suppression	10
Figure 2-3	Noise Suppression	10
Figure 2-4	Board and Terminal Locations	13
Figure 2-5	AC Power Input	14
Figure 2-6	Thermocouple Inputs	14
Figure 2-7	RTD Inputs	14
Figure 2-8	Milliamp, Volt and Millivolt Inputs	15
Figure 2-9	Digital Communications	15
Figure 2-10A	SPST Relay Output	16
Figure 2-10B	SPDT Relay Output	16
Figure 2-11	SSR Output	16
Figure 2-12	Current Output	17
Figure 2-13	24 VDC Power Supply Option	17
Figure 3-1	Keypad Features	19
Figure 4-1	Changing Pens	33
Table 3-1	Enable Mode Configuration Procedure	24
Table 3-2	Program Mode Configuration Procedure	28
Table 3-3	Alarm Set Mode Configuration Procedure	32
Table 4-1	Calibration Procedure	35
Table 4-2	Test Procedures and Description	40

---

## FLOW CHARTS

Flow - Alarm Set	32
Flow - Calibration	34
Flow - Enable	24
Flow - Program	25
Flow - Test	39

# Product Description 1.1

## 1.1.1 GENERAL

The instrument is a microprocessor based circular chart recorder capable of measuring, displaying and recording from a variety of inputs. Applications include temperature, pressure, flow and others. The instrument can be specified as either a single or dual pen unit.

Recording, alarm, or limit settings and other parameters are easily entered via the keypad. All user data can be protected from unauthorized changes by the Enable mode security system, and is protected against memory loss, as a result of AC power outage, by battery back-up.

The process variable input for each terminal is user configurable to directly connect to either thermocouple, RTD, mVDC, VDC, or mADC inputs. Changes in input type can easily be made by the user. Thermocouple and RTD linearization, as well as thermocouple cold junction compensation, is performed automatically. The instrument process variable inputs are isolated. An isolated 24 VDC regulated transmitter power supply can be provided in the instrument for use with up to two 4 to 20 mADC sensor transducers.

The instrument can be ordered to operate on either 115 VAC or 230 VAC power at 50/60 Hz. The 230 VAC option includes a switch for selecting either 230 VAC or 115 VAC operation. The recorder is housed in a structural foam enclosure suitable for panel or surface mounting.

**FIGURE 1-1**

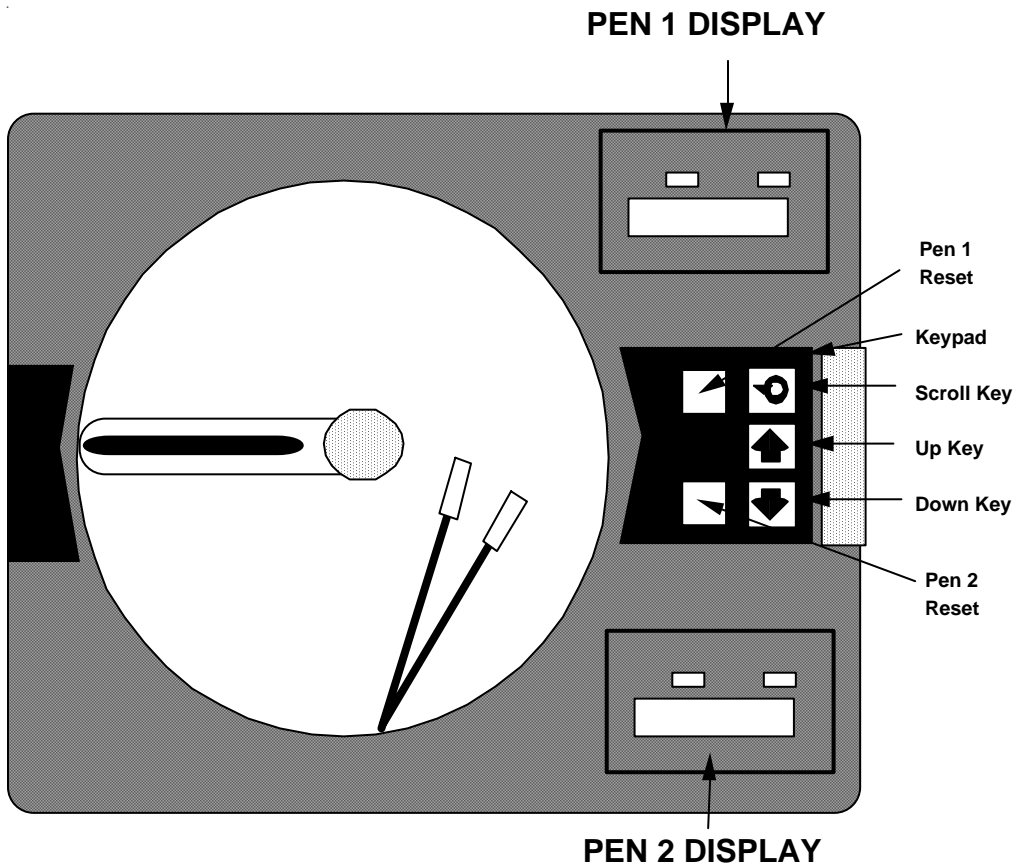

---

### 1.1.2 RECORDING

The instrument records the selected process variable on a 10-inch circular chart. One box of standard charts is provided with each recorder. Charts are available in a wide selection of ranges. Chart rotation speed is programmable from 0.1 to 999.9 hours per revolution in 0.1 hour increments. The instrument can be ordered with one or two pens. Pen 1 is red and Pen 2 is green. Pens are the disposable fiber-tip type.

---

### 1.1.3 DISPLAYS

Each instrument is provided with a digital display and status indicator for each pen provided, (See Figure 1-1, page 5). The digital display is configured to display the Process Value. The display in the upper right corner is for Pen 1, the display in the lower right corner is for Pen 2 (if provided). The display includes status indicators for Alarm 1 and Alarm 2, degrees C, degrees F, engineering units, and setpoint (for limits). See Figure 1-2 (below).

Display resolution is programmable for 0.1 or 1 degree for thermocouple and RTD inputs, and zero, one, two or three decimal places for other input types.

---

### 1.1.4 ALARM

Two alarm indications are standard for each pen on all instruments. Alarm settings are programmable. Alarm type may be set as process direct or reverse (high or low). Alarm outputs can be provided by assigning any relay(s) Single Pole/Single Throw (SPST or Solid State Relay (SSR) driver) to the respective alarm.

---

### 1.1.5 LIMIT

Limit indication is standard on limit devices. Limit settings are programmable. Limits may be High or Low and can be provided by assigning any relay to the respective limit.

---

### 1.1.6 PROCESS VALUE RE-TRANSMISSION OUTPUT

If an instrument is specified with mA/DC current output(s), any of the outputs may be programmed to operate as a process value re-transmission output. The output is scaleable.

---

### 1.1.7 DIGITAL COMMUNICATIONS

The instrument can be ordered with a Digital Communications option that provides the capability of bi-directional communications with a supervisory computer.

---

**FIGURE 1-2**

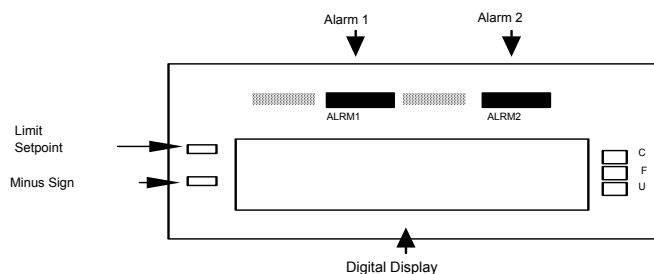

---

## Installation and Wiring 2.1

Read these instructions carefully before proceeding with installation and operation. Electrical code requirements and safety standards should be observed. Installation should be performed by qualified personnel.

**CAUTION: The Instrument AC power input is specified in the model number and on the wiring label affixed to the the top center of the platen. Verify the AC power input required by the instrument prior to proceeding with installation.**

---

## Unpacking 2.2

Remove the instrument from the carton and inspect for any damage due to shipment. If any damage is noticed due to transit, report and file a claim with the carrier. Write the model number and serial number of the instrument on the inside of the front cover of this Operation Manual for future reference.

---

## Location 2.3

Locate the instrument away from excessive moisture, oil, dust, and vibration. Do not subject the instrument to operating temperatures outside of the 32° to 131°F (0° to 55° C) range.

---

## Mounting 2.4

Figure 2-1 (page 8) shows an installation view and physical dimensions for a panel mounted instrument. The panel where the instrument will be mounted must provide rigid support for the approximately 20 pound instrument. Adjacent instruments may be mounted within a minimum of 2 inches horizontally and 3 inches vertically, providing that proper panel support is supplied.

PANEL MOUNTING HARDWARE REQUIRED: (not provided with instrument)

- (4) 1/4"-20 x 2" flat head bolts w/nuts
- (4) appropriate lock washers

### **PANEL MOUNTING:**

- 1) Cut panel opening to the dimensions illustrated in Figure 2-1 (page 8).
- 2) Insert the instrument in the panel opening. Firmly fasten the instrument to the panel using the nuts, bolts and lock washers.

### **SURFACE MOUNTING:**

- 1) Install the mounting brackets, ordered separately, on the vertical sides of instrument housing. Use the brackets to fasten the instrument to the surface.

**FIGURE 2-1**

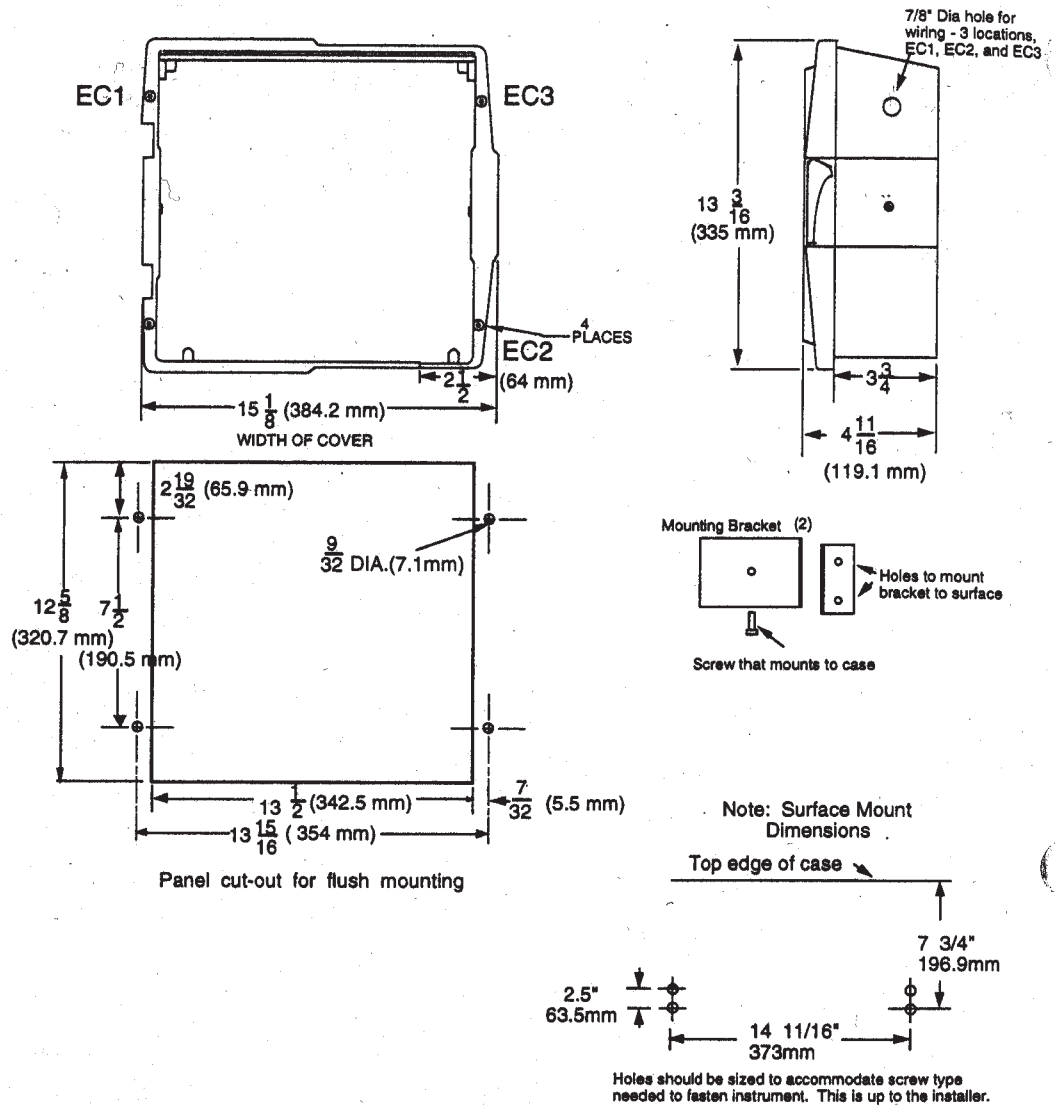

## Preparation for Wiring 2.5

### 2.5.1 WIRING GUIDELINES

Electrical noise is a phenomenon typical of industrial environments. The following are guidelines that must be followed to minimize the effect of noise upon any instrumentation.

#### 2.5.1.1 INSTALLATION CONSIDERATIONS

Listed below are some of the common sources of electrical noise in the industrial environment:

- Ignition Transformers
- Arc Welders
- Mechanical contact relay(s)
- Solenoids

Before using any instrument near the devices listed, the instructions below should be followed:

1. If the instrument is to be mounted in the same panel as any of the listed devices, separate them by the largest distance possible. For maximum electrical noise reduction, the noise generating devices should be mounted in a separate enclosure.



2. If possible, eliminate mechanical contact relay(s) and replace with solid state relays. If a mechanical relay being powered by an instrument output device cannot be replaced, a solid state relay can be used to isolate the instrument.
3. A separate isolation transformer to feed only instrumentation should be considered. The transformer can isolate the instrument from noise found on the AC power input.
4. If the instrument is being installed on existing equipment, the wiring in the area should be checked to insure that good wiring practices have been followed.

#### *2.5.1.2 AC POWER WIRING*

##### Earth Ground

The instrument includes noise suppression components that require an earth ground connection to function. To verify that a good earth ground is being attached, make a resistance check from the instrument chassis to the nearest metal water pipe or proven earth ground. This reading should not exceed 100 ohms. Each instrument should have a dedicated earth ground. Do not chain link multiple instrument ground wires.

##### Neutral (For 115VAC)

It is good practice to assure that the AC neutral is at or near ground potential. To verify this, a voltmeter check between neutral and ground should be done. On the AC range, the reading should not be more than 50 millivolts. If it is greater than this amount, the secondary of this AC transformer supplying the instrument should be checked by an electrician. A proper neutral will help ensure maximum performance from the instrument.

#### *2.5.1.3 WIRE ISOLATION/SEGREGATION*

The instrument is designed to promote proper separation of the wiring groups that connect to the instrument. The AC power wire terminals are located near the top of the instrument boards. The analog signal terminals are located near the bottom of the instrument boards. Maintain this separation of the wires to insure the best protection from electrical noise. If the wires need to be run parallel with any other wiring type(s), maintain a minimum 6 inch space between the wires. If wires must cross each other, do so at 90 degrees to minimize the contact with each other and reduce cross talk. Cross talk is due to the Electro Magnetic Field emitted by a wire as current passes through it.

#### *2.5.1.4 USE OF SHIELDED CABLE*

Shielded cable helps eliminate electrical noise being induced on the wires. All analog signals should be run with shielded cable. Connection lead length should be kept as short as possible, keeping the wires protected by the shielding. The shield should be grounded at one end only. The preferred grounding location is at the sensor, transmitter or transducer.

#### *2.5.1.5 NOISE SUPPRESSION AT THE SOURCE*

Usually, when good wiring practices are followed, no further noise protection is necessary. Sometimes in severe electrical environments, the amount of noise is so great that it has to be suppressed at the source. Many manufacturers of relays, contactors, etc. supply "surge suppressors" which mount on the noise source.

For those devices that do not have surge suppressors supplied, RC (resistance-capacitance) networks and/or MOV (metal oxide varistors) may be added.

Inductive Coils - MOV's are recommended for transient suppression in inductive coils connected in parallel and as close as possible to the coil. See Figure 2-2, page 10. Additional protection may be provided by adding an RC network across the MOV.

Contacts - Arcing may occur across contacts when the contact opens and closes. This results in electrical noise as well as damage to the contacts. Connecting a RC network properly sized can eliminate this arc.

For circuits up to 3 amps, a combination of a 47 ohm resistor and 0.1 microfarad capacitor (1000 volts) is recommended. For circuits from 3 to 5 amps, connect 2 of these in parallel. See Figure 2-3, page 10.

---

**FIGURE 2-2**

---

**FIGURE 2-3**

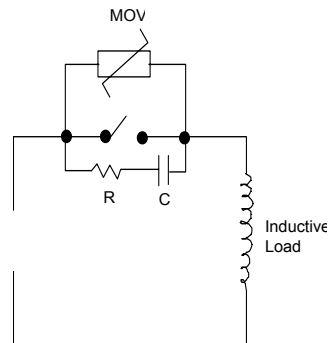

---

### **2.5.2 SENSOR PLACEMENT (THERMOCOUPLE OR RTD)**

Thermocouple lead resistance should not exceed 300 ohms. If this is exceeded, instrument accuracy could be affected.

Two wire RTD's should be used only with lead lengths less than 10 feet.

If the temperature probe is to be subjected to corrosive or abrasive conditions, it should be protected by the appropriate thermowell. The probe should be positioned to reflect true process temperature:

- In liquid media - the most agitated area.
- In air - the best circulated area.

**THERMOCOUPLE LEAD RESISTANCE**

Thermocouple lead length can affect instrument accuracy since the size (gauge) and the length of the wire affect lead resistance.

To determine the temperature error resulting from the lead length resistance, use the following equation:

$T_{err} = T_{Le} * L$     where;  $T_{Le}$  = value from appropriate table below  
 $L$  = length of leadwire in thousands of feet

TABLE 1

Temperature error in °C per 1000 feet of Leadwire									
AWG No.	Thermocouple Type:								
	J	K	T	R	S	E	B	N	C
10	.68	1.71	.76	2.05	2.12	1.15	14.00	2.94	2.53
12	1.08	2.68	1.21	3.30	3.29	1.82	22.00	4.68	4.07
14	1.74	4.29	1.95	5.34	5.29	2.92	35.00	7.44	6.37
16	2.74	6.76	3.08	8.30	8.35	4.60	55.50	11.82	10.11
18	4.44	11.00	5.00	13.52	13.65	7.47	88.50	18.80	16.26
20	7.14	17.24	7.84	21.59	21.76	11.78	141.00	29.88	25.82
24	17.56	43.82	19.82	54.32	54.59	29.67	356.50	75.59	65.27

TABLE 2

Temperature Error in °F per 1000 feet of Leadwire									
AWG No.	Thermocouple Type:								
	J	K	T	R	S	E	B	N	C
10	1.22	3.07	1.37	3.68	3.81	2.07	25.20	5.30	4.55
12	1.94	4.82	2.18	5.93	5.93	3.27	39.60	8.42	7.32
14	3.13	7.73	3.51	9.61	9.53	5.25	63.00	13.38	11.47
16	4.93	12.18	5.54	14.93	15.04	8.28	99.90	21.28	18.20
18	7.99	19.80	9.00	24.34	24.56	13.44	159.30	33.85	29.27
20	12.85	31.02	14.12	38.86	39.18	21.21	253.80	53.79	46.48
24	31.61	78.88	35.67	97.77	98.26	53.40	641.70	136.07	117.49

Example:

An MRC is to be located in a control room 660 feet away from the process. Using 16 AWG, type J thermocouple, how much error is induced?

$T_{err} = T_{Le} * L$   
 $T_{Le} = 4.93$  (°F/1000 ft) from Table 2

$T_{err} = 4.93$  (°F/1000 ft) \* 660 ft

$T_{err} = 3.3$  °F

### RTD LEAD RESISTANCE

RTD lead length can affect instrument accuracy, since the size (gauge) and length of the wire affect lead resistance.

To determine the temperature error resulting from the lead length resistance, use the following equation:

$$T_{err} = TLe * L \quad \text{where; } TLe = \text{value from Table 3 if 3 wire RTD or Table 4 if 2 wire RTD}$$
$$L = \text{length of lead wire in thousands of feet}$$

TABLE 3      3 Wire RTD

AWG No.	Error °C	Error °F
10	+/-0.04	+/-0.07
12	+/-0.07	+/-0.11
14	+/-0.10	+/-0.18
16	+/-0.16	+/-0.29
18	+/-0.26	+/-0.46
20	+/-0.41	+/-0.73
24	+/-0.65	+/-1.17

TABLE 4      2 Wire RTD

AWG No.	Error °C	Error °F
10	+/-5.32	+/-9.31
12	+/-9.31	+/-14.6
14	+/-13.3	+/-23.9
16	+/-21.3	+/-38.6
18	+/-34.6	+/-61.2
20	+/-54.5	+/-97.1
24	+/-86.5	+/-155.6

Example:

An application uses 2000 feet of 18 AWG copper lead wire for a 3 wire RTD sensor. What is the worst case error due to this leadwire length?

$$T_{err} = TLe * L$$
$$TLe = +/- .46 \text{ (°F/1000 ft) from Table 3}$$

$$T_{err} = +/- .46 (\text{±F/1000 ft}) * 2000 \text{ ft}$$

$$T_{err} = +/- 0.92\text{°F}$$

## Wiring Connections 2.6

All wiring connections are typically made to the instrument at the time of installation. Connections should be made at the terminal blocks, two 12 gauge wires maximum. Terminal blocks are designated TB1 through TB13. See Figure 2-4 for the terminal block locations (SPST Relay Board shown).

**FIGURE 2-4**

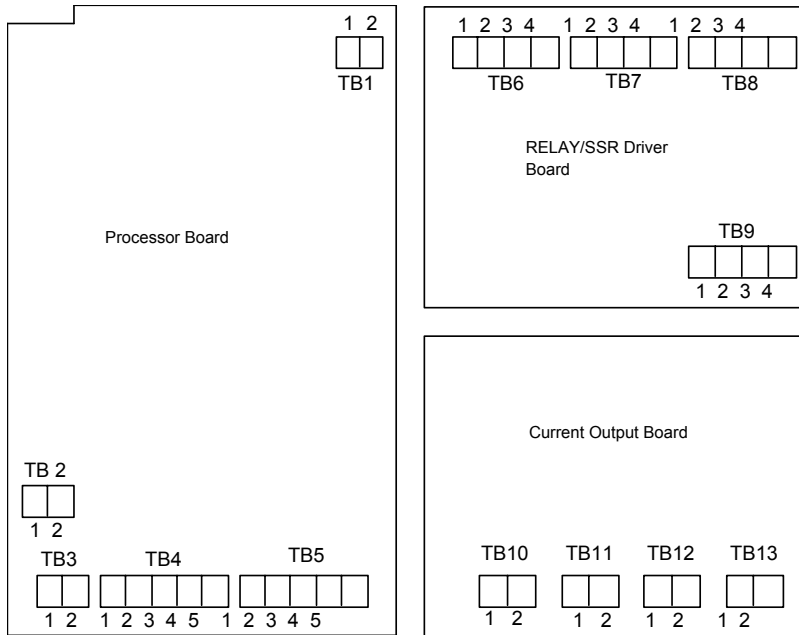

### 2.6.1 ELECTRICAL CONDUIT OPENINGS

The instrument case will have 3 or 4 conduit openings, depending upon the number of outputs specified. To help minimize electrical noise that may adversely affect the operation of the instrument the wires indicated below should be routed through the conduit opening specified. See Figure 2-1 (page 8) for conduit opening locations.

- EC1- AC Power Input
  - EC2- Analog input and mADC outputs
  - EC3- SPST, SPDT relay or SSR driver outputs
  - EC4- SPST, SPDT relay or SSR driver outputs (provided when > 4 relays & SSR Drivers are specified)
- Unused conduit openings should be sealed.

### 2.6.2 AC POWER WIRING CONNECTIONS

**WARNING: Avoid electrical shock. AC power wiring must not be connected at the source distribution panel until all wiring connections are completed.**

## FIGURE 2-5

### AC Instrument Power Input

Connect the 115 VAC hot and neutral to terminals 1 and 2 respectively of TB1. See Figure 2-4 (page 13) for Terminal Board locations on the instrument. Connect the 230 VAC one leg to each terminal, be sure to check the position of the Voltage Selector switch provided with 230 VAC instruments. The switch position must match the voltage input to the instrument.

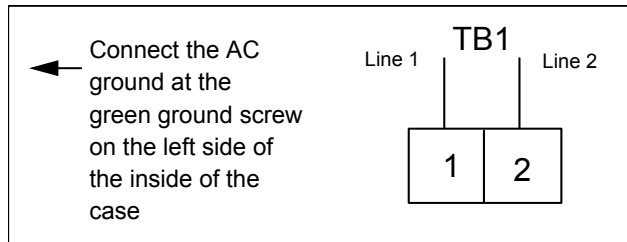

## FIGURE 2-6

### Thermocouple Inputs

Use TB4 for the Pen 1 input, and TB5 for the Pen 2 input. Connect the positive leg of the thermocouple to terminal 1, and the negative to terminal 2. Be sure that the input conditioning jumpers are properly positioned for a thermocouple input. See Appendix A-1 (page 50).

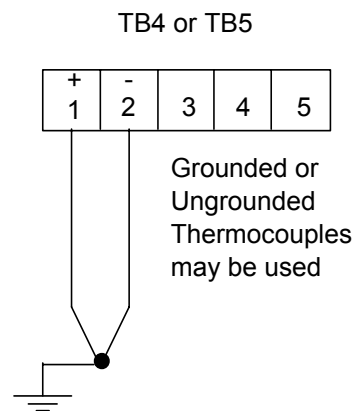

## FIGURE 2-7

### RTD Inputs

Use TB4 for the Pen 1 input, and TB5 for the Pen 2 input. Connections are shown for 3 wire and 2 wire RTD inputs. If a three wire device is used, install the common legs to terminals 2 and 3. If a two wire device is used, install a jumper between terminals 2 and 3. Be sure that the input conditioning jumpers are properly positioned for an RTD input. See Appendix A-1 (page 50)

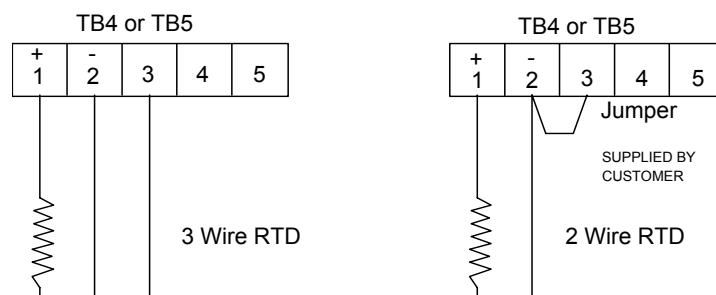

---

**FIGURE 2-8**

Volt, Millivolt and milliamp Input

Make the volt, millivolt or milliamp connections as shown below. Use TB4 for the Pen 1 input, and TB5 for the Pen 2 input. Terminal 1 is positive and terminal 2 is negative. The milliamp input requires the installation of an appropriate shunt resistor (ordered separately) between terminals 1 and 2. Be sure that input conditioning jumpers are in the correct positions for the input being connected. See Appendix A-1 (page 50).

**Note: Fault Detection is not functional for 0-5V or 0-20mA Inputs.**

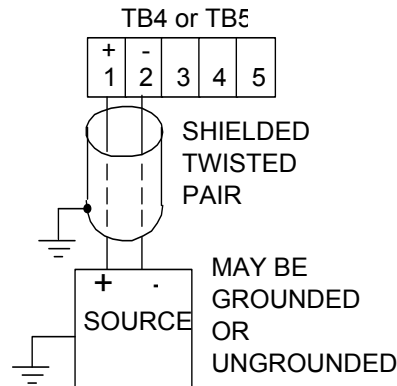

---

**FIGURE 2-9**

Digital Communications Options

Connections are made as shown using TB2. Refer to the Protocol Manual, Form #2878 for more details regarding the connections and how to use this option. This document is provided only when this option has been specified. If the communications network continues on to other instruments, connect the cable shields together, but not to the instrument. A terminating resistor should be installed at the terminals of the last unit in the communications loop. If the communications network ends at the instrument, the shield is not connected.

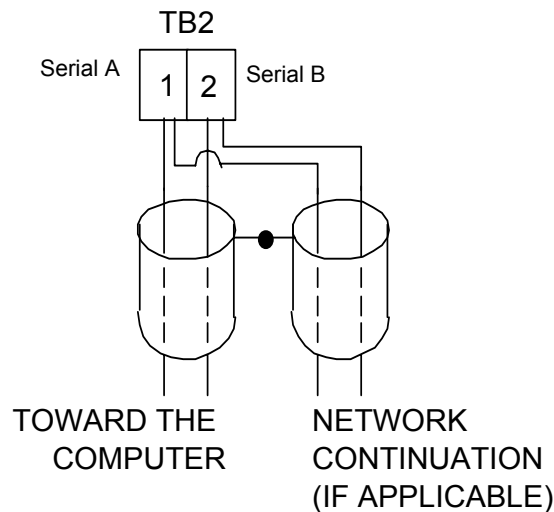

## 2.6.4 OUTPUT CONNECTIONS

Relay output(s) if provided in the instrument may be assigned to alarm output functions for Pen 1 and/or Pen 2 (if present) if instrument is recorder. Relay outputs, if instrument is a limit device, may be assigned to limit output functions. Current outputs may be assigned to process value retransmission output for Pen 1 and/or Pen 2 (if present). The assignment of the output function is accomplished in the Program mode, see Table 3-2 (page 28). SPST relay and/or SSR driver output(s) is/are designated as Relay A through Relay H. SPST relays begin with Relay A designation, then B, C, etc. SSR drivers begin with Relay H designation then G, F, etc. except when 4 SSR drivers are required in conjunction with SPDT relays, then designation E & F are not available. SSR driver designation becomes G, H, D, and C. SPDT relay output(s) are designated as Relay A and Relay B only.

### FIGURE 2-10A

#### SPST Relay Output

Connections are made to relays A through F as shown. Terminal connections are made using TB6 (Relay/SSR Driver A, B), TB7 (Relay/SSR Driver C, D), and TB8 (Relay/SSR Driver E, F).

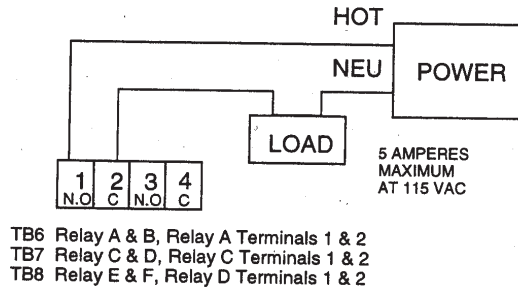

### FIGURE 10B

#### SPDT Relay Output

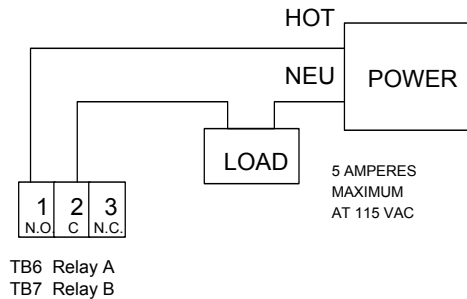

### FIGURE 2-11

#### SSR Driver Output

Connections are made to relays H through A as shown.

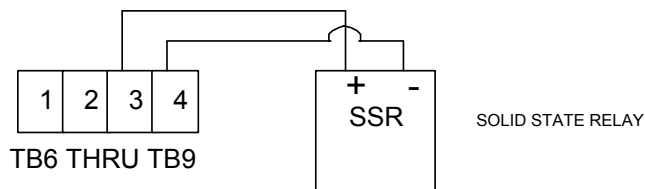

TB9 SSRD G, H - all cases  
TB8 SSRD E, F - no SPDT relays  
TB8 SSRD C, D - SPDT relay/s E and F not available



## FIGURE 2-12

### Current Output

Connections are made to current outputs A thru D as shown. Each current output is programmable as either 4 to 20 mA DC or 0 to 20 mA DC. Each output must be assigned to the desired function (refer to Table 3-2, page 28, for details.) Terminal connections are made using TB10 through TB13 for current output A through D respectively. Connect positive lead (+) to terminal 1 and the negative lead (-) to terminal 2. Current outputs will operate up to 650 ohms maximum load.

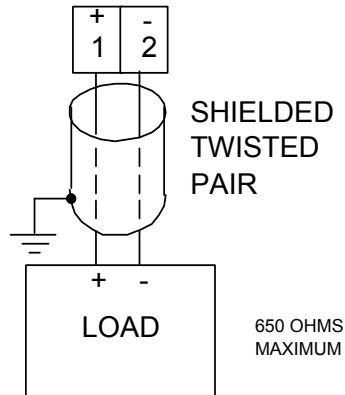

## FIGURE 2-13

### Transmitter Power Supply Input

If the isolated 24 VDC regulated transmitter power supply has been specified, the connections should be made as shown. Connections are made using TB3, terminal 1 is positive and terminal 2 is negative. The power supply is capable of providing the power needed by as many as 2 transmitters.

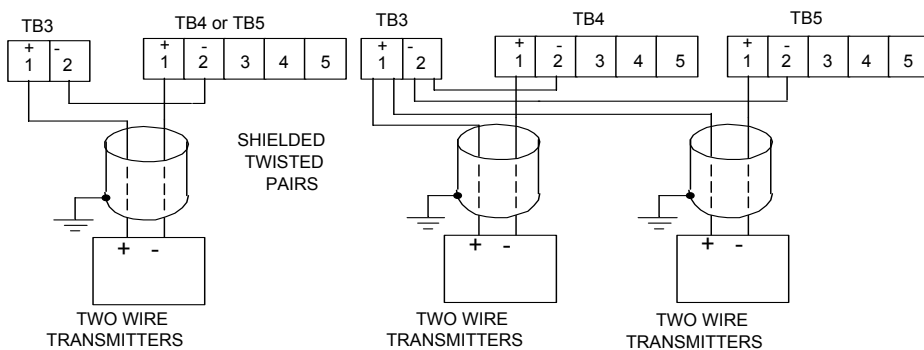

## Configuration 3.1

After completing installation and wiring of the instrument the configuration (set up) procedures must be performed to prepare the instrument for operation of the intended application. The procedures include selecting specific parameters, entering data and possible jumper positioning. Once properly configured the instrument will retain the user selections in memory. This procedure need not be repeated unless required by changes in the application.

Parameter selections and data entry are made via the front keypad. To ease configuration and operation, user entered data has been divided into several sections referred to as modes. Each mode contains a different type of data or may be used for specific operating functions. For two pen instruments, some modes are common to both pens. These modes are as follows:

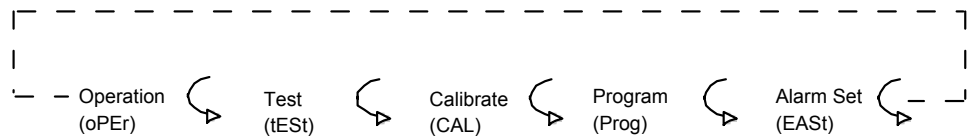

<b>MODE</b>	<b>DISPLAY CODE</b>	<b>FUNCTION</b>	<b>DESCRIPTION</b>
Off	<b>oFF</b>	Operation	Limits and Alarms are Off. Chart may stop rotating(selectable)
Operate	<b>oPEr</b>	Operation	Limits and Alarms are Active
Test	<b>tESt</b>	Service	Tests Instrument Operation
Calibration	<b>CAL</b>	Service	Calibrates Instrument
Program	<b>Prog</b>	Configuration	Configure Operating Parameters
Alarm Set	<b>ASEt</b>	Configuration & Operation	Enter Alarm Settings
Enable	<b>Enab</b>	Configuration	Mode security system, can lock out everything except Off and operate (See Appendix A-1, page 50, for hardware lockout information).

Associated with each mode is a series of unique displays which are accessed via the front keypad.

Prior to first time operation of the unit, the configuration procedures for the Program and Alarm Set modes must be performed as applicable. Calibration and Test modes are not used as part of the instrument configuration or operation. These are used for service and maintenance functions and are discussed in Section 4.6 of this manual (page 43).

---

## Shipped Configuration/Jumper Positioning 3.2

Each instrument is factory shipped ready to accept a thermocouple input on TB 4 and TB 5. All configuration parameters in each mode are set to default values. These defaults are shown in tabular form after the description for each mode. Instrument AC power input is as specified in the instrument model number and is shown on the ratings label. The 230 VAC option includes a switch in the instrument for selecting either 230 VAC or 115 VAC input power. If this feature is provided, verify AC input and switch position before applying power to the instrument.

---

### 3.2.1 JUMPER POSITIONING

Jumpers are used to provide a security lockout feature and to condition the sensor inputs. All jumpers are typically of the three pin type and have two functions. All jumpers are located on the instrument Processor board. The instrument board layout and jumper locations are shown in Appendix A-1 (page 50). Check the actual jumper position in the unit to be configured and verify the proper position for the intended application. .

*The sensor input jumpers JU4, JU5, JU6 and JU7 condition the sensor input at a basic level. Detailed input type selection is made in the Program mode.*

---

## Operation Summary 3.3

Prior to operation the Program mode parameters and Alarm Setting(s), if used, must be selected for the application. Data and parameter entry is made by stepping through each mode and making an appropriate response or entry to each step.

---

### 3.3.1 KEYPAD OPERATION

Refer to Figure 3-1 for the Keypad features. Use the SCROLL, UP and DOWN keys as indicated to program and operate the instrument.

---

**FIGURE 3-1**

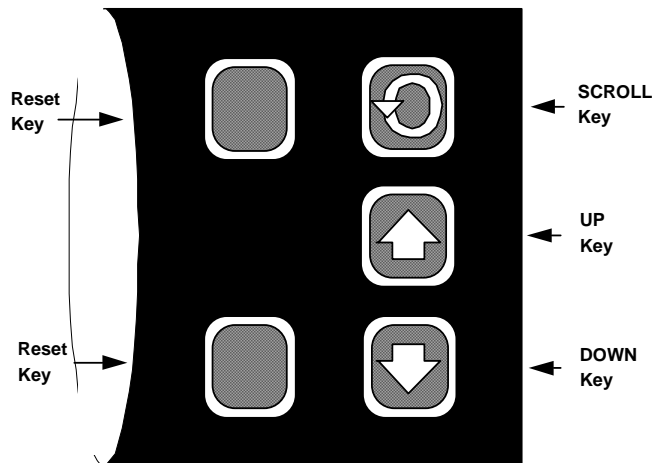

---

### 3.3.2 CONFIGURATION DISPLAYS

Each pen specified is provided with its own 4 digit LED display. These are used during configuration to display the parameter codes and values. The display located in the upper right hand corner of the instrument is used to show the codes for Pen 1 and those that are common between Pens 1 and 2. The display in the lower right hand corner is used to show the configuration codes for Pen 2 (if provided).

During normal operation, the display(s) are used to indicate process value(s) as selected in the Program mode.

---

### 3.3.3 MODE SELECTION

If the instrument is either in the Off mode or the Operation mode repeated pressing and releasing of the SCROLL key will cause the instrument to display the code corresponding to each mode that is enabled. To enter a mode, while the code is displayed, press the Down key.

Entry into any mode except the Operation and Enable modes, will cause the alarm(s) to turn off and any process retransmission value output(s) to be 0 %.

---

## Start Up Procedure 3.4

All configuration parameters are listed in Tables 3-1 through 3-3 (pages 24-32).

For a single pen instrument, parameters for each mode are displayed in the upper right display. If the instrument being configured is a two pen model, a sequence of applicable parameters will be displayed in the Pen 2 display after the Pen 1 parameters have been reviewed and configured. After the Pen 2 parameters have been completed, parameters common to both pens will be configured and displayed in the Pen 1 display.

The instrument is provided with a time out feature. If the instrument is in any mode and no keypad activity takes place for 30 seconds, the instrument will time out and exit the mode automatically. The display will be the code for the respective mode. If a mode code is displayed for 5 seconds with no keypad activity, then the time out will cause the instrument to proceed to either the Operation or Off mode, depending upon which operational state was in use before entrance into the mode.

---

### 3.4.1 POWER UP PROCEDURE

#### Step 1

Verify that all electrical connections have been properly made before applying power to the unit.

#### Step 2A - For instruments with software revision R2.99 and below

Upon power up, **7XXX** will be displayed (X representing digits), then **XXXX**, then **XXXX**, identifying the twelve digit model number as defined in the order matrix. Next, the EPROM part number will be indicated **P-XX**. After the EPROM part number, the software revision level will be displayed in the format **rX.XX** then **tSt1**, **tSt2**, and **tSt3** will be displayed while Test 1 through 3 are executed automatically. Upon successful completion of these test, **oPEr** or **oFF** will be displayed for about 3 seconds. The mode displayed will be the mode the instrument was in when the power was turned off. During this time, the operator may select another mode (Alarm Set, Enable) or non-operational mode (Test, Program, Cal).

Step 2B - For instruments with software revision r3.00 and above

Upon power up, a brief flash on all displays (upper and, if equipped, lower) will occur to show the instrument is "alive". Then **7XXX** will be displayed (X representing digits) then **XXXX**, then **XXXX**, identifying the twelve digit model number as defined in the order matrix. Next, the EPROM part number will be indicated **P-XX**. After the EPROM part number, the software revision level will be displayed in the format **rX.XX** followed by **P.dn** (if **Pen Action** on **Power Up**, **PAPU**, in Program Mode is set to **0**, pens go to "home" position at power up). During this display, the decimal point after the "P" will blink to show the mode is active. Upon successful completion of this routine, **oPEr** or **oFF** will be displayed for about 3 seconds. The mode displayed will be mode that the instrument was in when the power was turned off. During this time the operator may select another mode (Alarm Set, Enable) or non-operational mode (Test, Program, Cal).

Step 3

If any error messages are displayed, refer to Section 4.6 (page 43) for a definition of these error messages and the required action.

---

## Front Panel Operation 3.5

### 3.5.1 DIGITAL DISPLAY AND STATUS LED'S

The digital display provided for each pen has 4 digits and a decimal point. Each digit has seven segments and is capable of producing numeric characters from 0-9 and certain alpha characters. The digital display is used to provide indication of process variable as well as displaying codes used for configuration and operation of the instrument.

ALRM1	Red	Rcdr - Lights when Alarm 1 is on. Limit - Lights when Limit has been exceeded.
ALRM2	Red	Lights when Alarm 2 is on.
C	Red	Lights to indicate that the process value is in terms of degrees C (Celsius).
F	Red	Lights to indicate that the process value is in terms of degrees F (Fahrenheit).
U	Red	Lights to indicate that the process value is in terms of Engineering units.
-	Red	Lights to indicate a negative displayed value.
SP (Limits only)	Green	Indicates that the value displayed is the setpoint

Refer to Figure 1-2 (page 6) for the display features.

---

## 3.5.2 KEYPAD CONTROLS

The keys provided on the keypad and their functions include:

<b>SCROLL:</b>	Used to :	Advance the display through the enabled modes. While in a mode, used to sequence the parameter codes and values. Exit some Test and Calibration functions. Work in conjunction with other keys.
<b>UP:</b>	Used to:	Exit a mode. Turn a mode On in the Enable mode. Increase a numerical value Work in conjunction with other keys. Display the setpoint (Limit device only). Increase the setpoint (Limit device only).
<b>DOWN:</b>	Used to:	Enter a mode Turn a mode Off in the Enable mode Decrease a numerical value Work in conjunction with other keys. Display the setpoint (Limit device only). Decrease the setpoint (Limit device only).
<b>RESET:</b>	Used to: (Limit Only)	Reset the limit output only when the condition that caused the limit has been cleared.

### LAMP TEST

From the Off or Control modes, all display and status LEDs can be illuminated simultaneously by depressing the UP and DOWN keys at the same time. Any defective LEDs will not light.

### CHANGE CHART (also see Changing Charts, Section 4.2)

If the UP and DOWN keys are held depressed for more than 2 seconds but less than 4 seconds, the display will show **Cchg** momentarily. The pen(s) will move to and remain at a point above the top graduation on the chart and the chart will stop rotation to allow the chart to be changed. The pens will remain fully upscale with the chart OFF; otherwise, the unit will continue to operate normally in the current mode. To restore pen(s) position and chart rotation, press the UP and DOWN keys for more than 2 seconds but less than 4 seconds.

### PEN RESYNCHRONIZATION

To resynchronize the pen(s), depress the UP and DOWN keys for 4 seconds, the display will show **P dn** momentarily, the pen(s) are driven to the "Pen Home" position below the bottom graduation on the chart while the unit resynchronizes their position. After about 14 seconds, the pen(s) will return to their correct position. All other functions of the unit's present mode continue to operate normally.

#### 3.5.2.1 OFF MODE

When in the Off Mode, all outputs and alarms are off. The chart (if selected) may stop rotating. To exit the Off mode, press the SCROLL key until **OPeR** is displayed, then press the DOWN key.

#### 3.5.2.2 ENTERING THE ENABLE MODE

The Enable mode is entered by pressing and holding the UP and DOWN keys simultaneously while in the Operate or Off modes. Holding the two keys depressed for 10 seconds will cause the display to show the **EnAb** prompt which is the entry point into the Enable mode.

A hardware jumper located on the Processor Board (See Appendix A-1, page 50) can be used to lock/unlock the Enable mode. When the jumper is moved to the locked position,

---

entry into the Enable mode is not possible until the jumper is moved to the unlock position.

### 3.5.3 PROGRAM MODE CONFIGURATION PROCEDURE

The Program mode provides a means to configure or reconfigure the instrument operation within the limits of the hardware specified and provided. Parameters to be configured will be only those that are applicable as determined by the hardware provided.

Review the configuration procedures in Table 3-2 (page 28). Use the "Your Setting" column in the table to record your selections.

#### 3.5.3.1 ENTERING THE PROGRAM MODE

Press and release the SCROLL key until **Prog** is displayed. This is the mode code for the Program mode. With **Prog** displayed press the DOWN key to enter the Program mode. If the **Prog** code does not appear refer to Table 3-1 (page 24) for Enable mode instructions.

#### 3.5.3.2 MOVEMENT IN THE PROGRAM MODE

Each time the DOWN key is pressed while a parameter code is being displayed, such as **dFF**, another parameter code will be displayed. Press the SCROLL key with a parameter code displayed to view the parameter value selected. Use the UP or DOWN keys to change the parameter value as desired for the application. Pressing the SCROLL key with a parameter value displayed will cause the next parameter code to be displayed.

Depressing the UP key while a parameter code is displayed will exit the program mode and the **Prog** code will appear in the display. Use the SCROLL key to proceed to any other mode.

#### 3.5.3.3 ONE PEN INSTRUMENTS

For instruments specified and provided with only one pen, all configuration and operating parameters and values will appear in the upper display which is dedicated to Pen 1. This is the only display provided.

#### 3.5.3.4 TWO PEN INSTRUMENTS

Instruments specified and provided with two pens require configuration of each pen. Configuration of the Program mode is broken into three parts; First, the parameters that are associated with Pen 1 will be displayed in the upper display. Next, the Program mode parameters associated with Pen 2 will be displayed in the lower display. Finally, parameters that are common to both pens, such as chart rotation speed, will be displayed for configuration in the upper display. Access to either the Pen 1, Pen 2 or Unit (common) parameters may be quickly obtained by depressing the Down key with **Prog** displayed. The display will be **PEn1**, press and release the SCROLL key and display will sequence the **PEn2**, **unit** and **PEn1** codes. Press the DOWN key to enter the section of the Program mode desired.

#### 3.5.3.5 PROGRAM MODE CONFIGURATION

Refer to Table 3-1 (page 24) for configuration procedures for the Program mode. All possible parameters are shown for illustration purposes. Only those parameters applicable to each respective pen will actually be shown.

### 3.5.4 ALARM SET MODE CONFIGURATION PROCEDURE

The Alarm Set mode allows the entry, review or altering of the alarm setting(s). Parameters to be configured will be those that are assigned in the Program mode.

Review the entry procedure and the configuration procedures in Table 3-3 (page 32). Use the "Your Setting" column in the table to record your programming.

#### 3.5.4.1 ENTERING THE ALARM SET MODE

From the Operate or Off mode, press and release the SCROLL key until **ASet** is displayed.

This is the mode code for the Alarm Set mode. With **ASet** in the display, press the DOWN key to enter the mode. If the **ASet** code does not appear refer to Table 3-1 (page 24) for Enable mode instructions.

### 3.5.4.2 MOVEMENT IN THE ALARM SET MODE

Each time the DOWN key is pressed while a parameter code is being displayed another parameter code will be displayed. Pressing the SCROLL key while a parameter code is displayed will cause the parameter value to appear. Pressing the SCROLL key with a parameter value displayed will cause the next parameter code to be displayed. Pressing the UP key while a parameter code is being displayed will exit the Alarm Set mode and the **ASet** code will appear in the display. Using the SCROLL key at this point will allow you to proceed to any other mode.

### 3.5.4.3 ALARM SET MODE CONFIGURATION

Refer to Table 3-3 (page 32) for configuration procedures for the Alarm Set. All possible parameters are shown for illustration purposes. Only those parameters applicable to each respective pen will actually be shown. **Alarm Set are adjusted on-line. The instrument will react to changes as they are made. The Decimal Point Position, as defined by the dPoS parameter in the Program mode, will affect the resolution and adjustment limits for Alarm Set mode parameters.**

## TABLE 3-1 ENABLE MODE CONFIGURATION PROCEDURE

To enter the Enable mode, press the UP and DOWN keys while in **oPEr** or **oFF** modes. All the display lamps will light. After 2 seconds, the display will show **Cchg** and the pen(s) will move to and remain at a point above the top graduation on the chart. Continue to press the UP and DOWN keys, after 2 additional seconds, the display will show **P dn** and the pens(S) are driven below the bottom graduation on the chart. After 6 more seconds, the display will show **EnAb**. Release the keys and the display will change to **EtSt**. Press and release the DOWN key and each mode to be enabled/disabled will be displayed. With the enable mode prompt for the desired mode displayed press the SCROLL key to verify that the displayed mode is either **on** (enabled) or **oFF** (disabled). Press the DOWN key to turn off the mode, press the UP key to turn on the mode or press the SCROLL key to advance the display to the next enable mode prompt. Use the "Your Setting" column in the table to record your programming. The Test and Calibration modes are factory set to **oFF** (disabled).

STEP	DESCRIPTION	DISPLAY CODE	AVAILABLE SETTINGS	FACTORY SETTING	YOUR SETTING
1	Test Mode	<b>EtSt</b>	on or oFF	oFF	
2	Calibration Mode	<b>ECAL</b>	on or oFF	oFF	
3	Program Mode	<b>EPro</b>	on or oFF	on	
4	Alarm Set Mode	<b>EASt</b>	on or oFF	on	
5	Setpoint Change (Limit Only)	<b>ESPC</b>	on or oFF	on	

### KEY

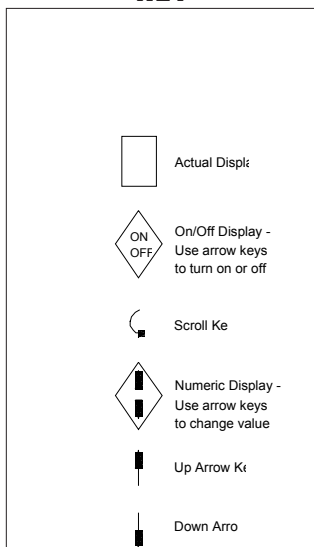



# ENABLE MODE FLOW CHART

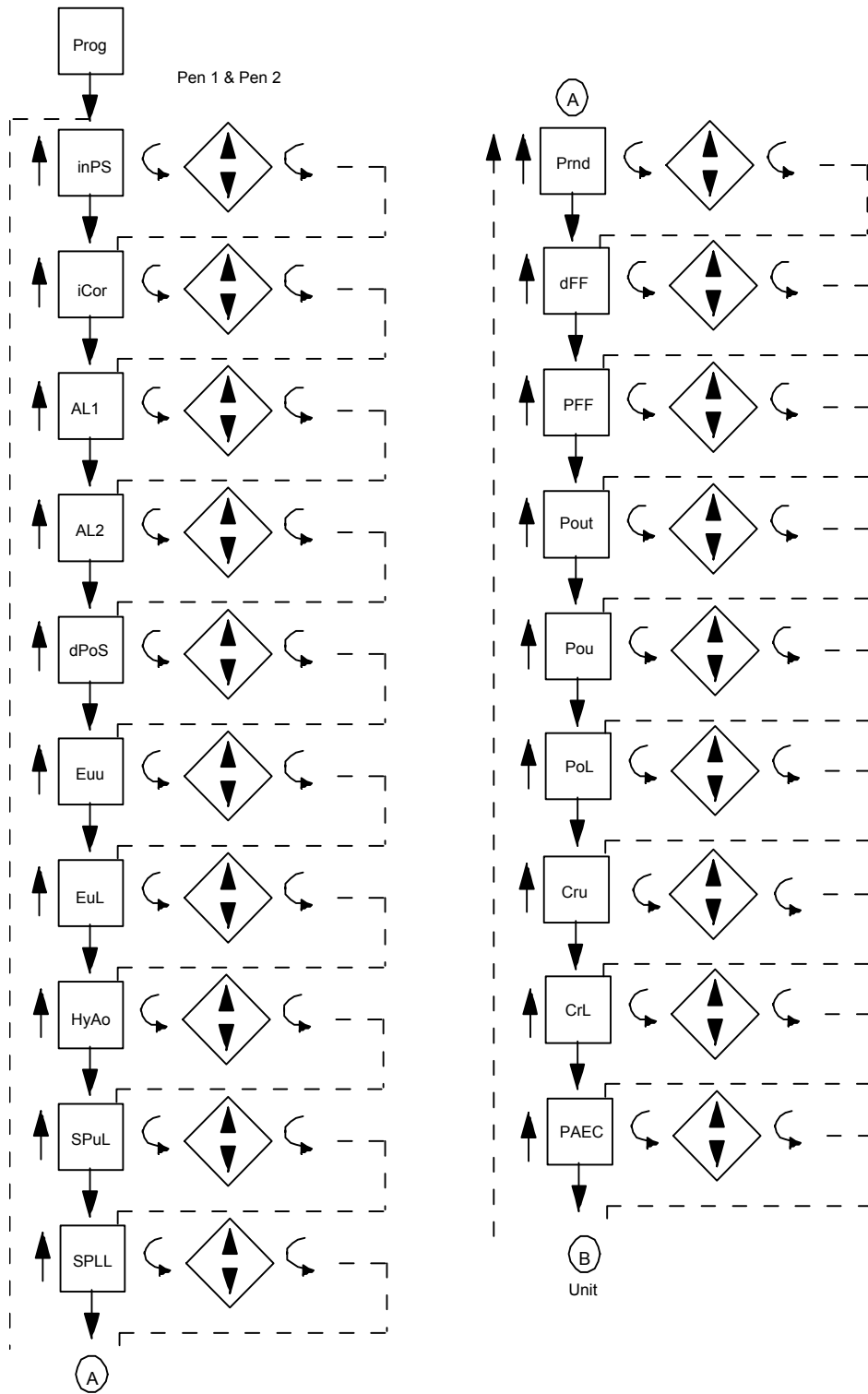

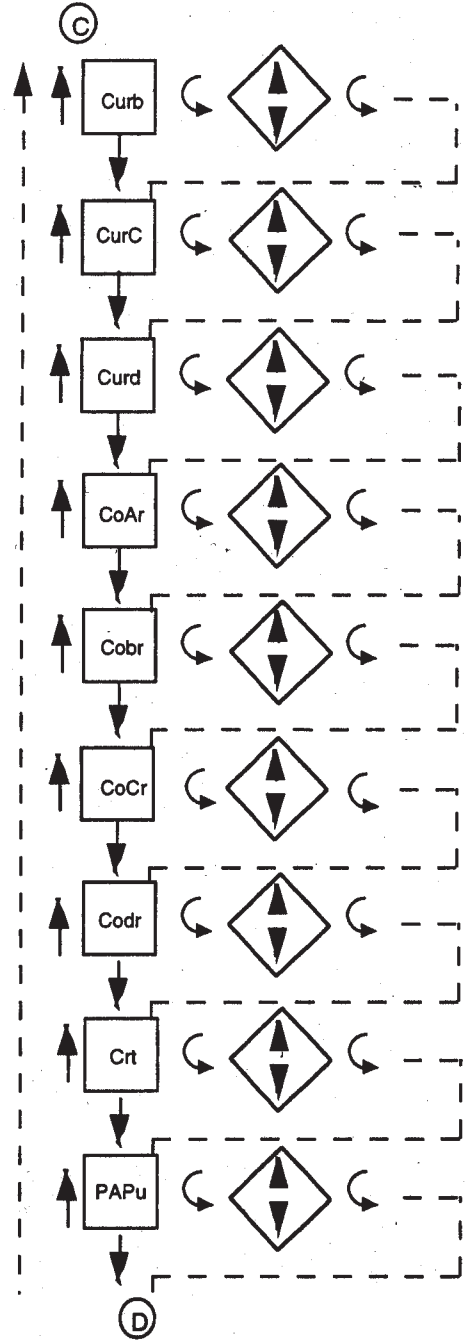
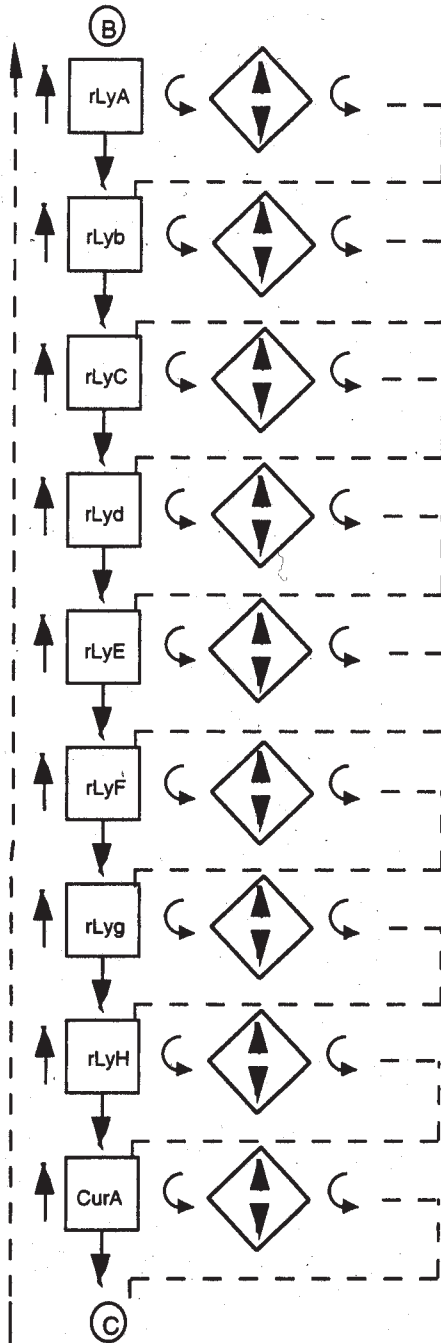

**KEY**

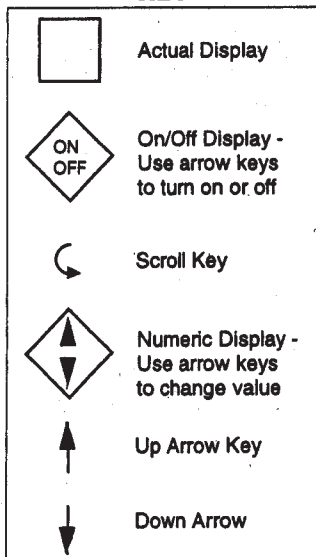

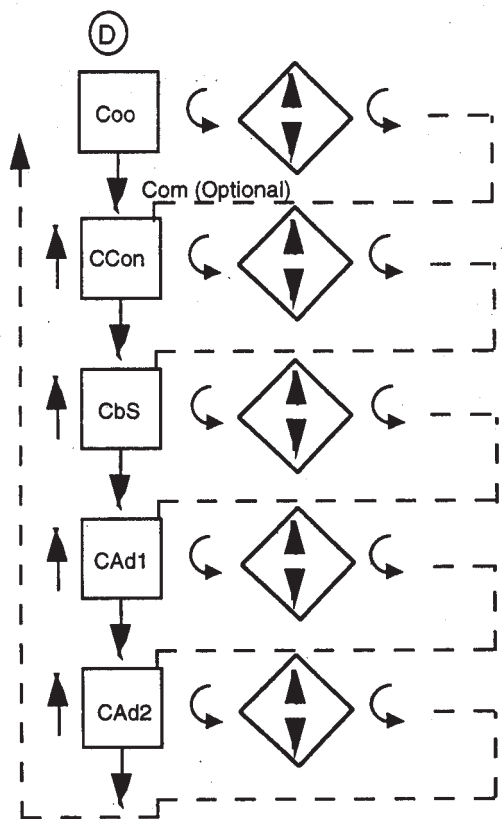

## PROGRAM MODE FLOW CHART

### TABLE 3-2 PROGRAM MODE CONFIGURATION PROCEDURE

Press the SCROLL key until **Prog** is displayed. Press the DOWN key to enter the Program mode. Pen 1 will be displayed in the upper display. To enter the Pen 1 parameter, press the DOWN key. To enter the Pen 2 parameter, if provided, press the Scroll key, then the DOWN key. To enter the unit parameter, press the SCROLL key with either Pen 1 or Pen 2 displayed until unit is displayed, then press the DOWN key. Press the SCROLL key to advance the display through the parameter codes and their values. Use the UP and DOWN keys to adjust the values. After adjusting a parameter, press the SCROLL key to proceed to the next parameter. After all selections have been made, press the UP key with a parameter in the display (not a setting) to exit the mode. For two pen instruments the parameters and values which are applicable to Pen 1 will appear in the upper display, then the parameters and values which are applicable to Pen 2 will appear in the lower display. Then the unit parameters and values will appear in the upper display.

STEP	DESCRIPTION	DISPLAY AVAILABLE CODES	AVAILABLE SETTINGS	FACTORY SETTING	YOUR SETTING
1	Input Select	<b>inPS</b>	0=J T/C degrees C 1=J T/C degrees F 2=K T/C degrees C 3=K T/C degrees F 4=T T/C degrees C 5=T T/C degrees F 6=R T/C degrees C 7=R T/C degrees F 8=S T/C degrees C 9=S T/C degrees F 10=E T/ C degrees C 11=E T/C degrees F 12=B T/ C degrees C 13=B T/C degrees F 14=N T/ C degrees C 15=N T/C degrees F 16=C T/ C degrees C 17=C T/C degrees F 20=RTD degrees C 21=RTD degrees F 30=0 to 5 VDC / 0 to 20mA 31=1 to 5 VDC / 4 to 20mA 32=0 to 50 mVDC 33=10 to 50 mVDC 34=0 to 25 mVDC	<b>1</b>	
<b>Note: Fault detection is not functional for 0-5V or 0-20mA Inputs</b>					
2	Input Correction	<b>iCor</b>	-300 to 300 degrees/units	<b>0</b>	
3	Alarm 1 (Recorder Only)	<b>AL1</b>	0=None 1=Process Alarm-Direct 2=Process Alarm-Reverse	<b>0</b>	
	Alarm 1 (Limit Only)	<b>AL1</b>	0=None 1=Low Limit 2=High Limit		
4	Alarm 2	<b>AL2</b>	0=None 1=Process Alarm - Direct 2=Process Alarm- Reverse	<b>0</b>	
5	Display Select (Limit Only)	<b>diSP</b>	1=Process Value Only 2=Process Value/setpoint	<b>1</b>	

STEP	DESCRIPTION	DISPLAY CODES	AVAILABLE SETTINGS 3=Deviation Only 4=Deviation and Setpoint 5=Setpoint Only	FACTORY SETTING	YOUR SETTING
6	Decimal Position	<b>dPoS</b>	0=None 1=One decimal position 2=Two decimal positions 3=Three decimal positions <b>RTD and thermocouple inputs are limited to either 0 or 1 decimal positions</b>	<b>0</b>	
7	Engineering Units Upper Value (If Input Select = 30, 31, 32, 33, 34)	<b>Euu</b>	-9999 to 9999	<b>1000</b>	
8	Engineering Units Lower Value (If Input Select = 30, 31, 32, 33, 34)	<b>EuL</b>	-9999 to 9999	<b>0</b>	
9	Hysteresis for Alarm Outputs	<b>HyAo</b>	0 to 300 degrees/units Width of Hysteresis Band (See page 54 for definition)	<b>3</b>	
10	Setpoint Upper Limit (Limit Only)	<b>SPuL</b>	-9999 to 9999	<b>1400</b>	
11	Setpoint Lower Limit (Limit Only)	<b>SPLL</b>	-9999 to 9999	<b>0</b>	
12	Process Rounding of Displayed value	<b>Prnd</b>	0=No Rounding 1 to 100 degrees/units	<b>0</b>	
13	Display Filter Factor	<b>dFF</b>	1=No filtering 1 to 20 units (number of values averaged)		<b>1</b>
14	Process Filter Factor	<b>PFF</b>	1 = No filtering 1 to 20 units (number of values averaged)	<b>1</b>	
15	Process Value Output (If <b>Pout</b> =0 then <b>Pou</b> and <b>PoL</b> will not be displayed)	<b>Pout</b>	0=Not selected 1=Selected	<b>0</b>	
16	Process Output Upper Value	<b>Pou</b>	-9999 to 9999 degrees/units	<b>2000</b>	
17	Process Output Lower Value	<b>PoL</b>	-9999 to 9999 degrees/units	<b>0</b>	
18	Chart Range Upper Value	<b>Cru</b>	-9999 to 9999 degrees/units	<b>200</b>	
19	Chart Range Lower Value	<b>CrL</b>	-9999 to 9999 degrees/units	<b>0</b>	
20	Pen Action on Error Condition	<b>PAEC</b>	0=Pen goes to 0% of chart span 1=Pen goes to 100% of chart span	<b>1</b>	

Pressing the SCROLL key with the **PAEC** parameter value displayed in the Pen 1 window will advance the display of a single pen instrument to the unit parameters. Pressing the SCROLL key with the **PAEC** parameter displayed in the Pen 1 window of a two pen instru-

STEP	DESCRIPTION	DISPLAY CODES	AVAILABLE SETTINGS	FACTORY SETTING	YOUR SETTING
------	-------------	---------------	--------------------	-----------------	--------------

ment will advance the display to be **inPS** in the Pen 2 window. The Pen 2 Program mode parameter selections can be made now. Pressing the SCROLL key with the **PAEC** parameter value displayed in the Pen 2 window will cause the display to advance to the unit parameters.

**Unit Parameters**

21	Relay A Assignment	<b>rLyA</b>	0=Not assigned 1=Assigned to Alarm 1-Pen 1 2=Assigned to Alarm 2-Pen 1 3=Assigned to Alarm 1-Pen 2 4=Assigned to Alarm 2-Pen 2	<b>0</b>	
22	Relay B Assignment	<b>rLyb</b>	Same selection as <b>rLyA</b>	<b>0</b>	
23	Relay C Assignment	<b>rLyC</b>	Same selection as <b>rLyA</b>	<b>0</b>	
24	Relay D Assignment	<b>rLyd</b>	Same selection as <b>rLyA</b>	<b>0</b>	
25	Relay E Assignment	<b>rLyE</b>	Same selection as <b>rLyA</b>	<b>0</b>	
26	Relay F Assignment	<b>rLyF</b>	Same selection as <b>rLyA</b>	<b>0</b>	<b>0</b>
27	Relay G Assignment	<b>rLyg</b>	Same selection as <b>rLyA</b>	<b>0</b>	
28	Relay H Assignment	<b>rLyH</b>	Same selection as <b>rLyA</b>	<b>0</b>	
29	Current Output A Assignment	<b>CurA</b>	0=Not Assigned 1=Assigned to Process Value Output-Pen 1 2=Assigned to Process Value Output-Pen 2	<b>0</b>	
30	Current Output B Assignment	<b>Curb</b>	Same selection as <b>CurA</b>	<b>0</b>	
31	Current Output C Assignment	<b>CurC</b>	Same selection as <b>CurA</b>	<b>0</b>	
32	Current Output D Assignment	<b>Curd</b>	Same selection as <b>CurA</b>	<b>0</b>	
33	Current Output A Range	<b>CoAr</b>	0=0-20 mA 1=4-20 mA	<b>1</b>	
34	Current Output B Range	<b>Cobr</b>	Same selection as <b>CoAr</b>	<b>1</b>	
35	Current Output C Range	<b>CoCr</b>	Same selection as <b>CoAr</b>	<b>1</b>	
36	Current Output D Range	<b>Codr</b>	Same selection as <b>CoAr</b>	<b>1</b>	
37	Chart Rotation Time	<b>Crt</b>	0.1 to 999.0 hours per rotation		<b>1.0</b>
38	Pen Action on Power Up	<b>PAPu</b>	0=Pen(s) go to the "home" position (towards chart center) when powered up 1=Pen(s) remain in last position prior to power down	<b>0</b>	
39	Chart Operation	<b>Coo</b>	0=Chart continues rotating	<b>0</b>	

<b>STEP</b>	<b>DESCRIPTION</b>	<b>DISPLAY CODES</b>	<b>AVAILABLE SETTINGS</b>	<b>FACTORY SETTING</b>	<b>YOUR SETTING</b>
	in Off Mode		in the Off mode 1=Chart stops rotating while in the Off mode		

### **Communications Options Parameters**

40	Communication Configuration	<b>CCon</b>	0=Off 1=Monitor Mode (Read Only) 2=Normal Mode (Read and Write) 3=Total Access with Limit Checking 4=Total Access without Limit Checking	<b>3</b>	
41	Communication Bit Rate Selection	<b>CbS</b>	1 to 6 1=300 2=600 3=1200 4=2400 5=4800 6=9600	<b>6</b>	
42	Communications Address-Pen 1	<b>CAd1</b>	0 to 99	<b>1</b>	
43	Communications Address-Pen 2	<b>CAd2</b>	0 to 99	<b>2</b>	

## KEY

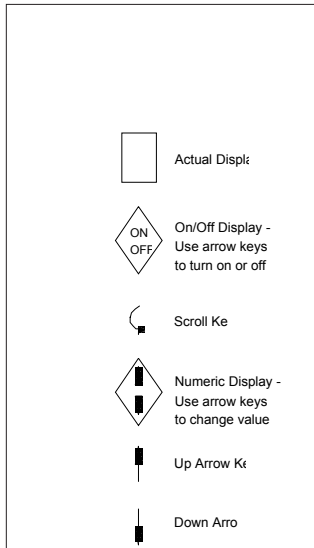

## ALARM SET FLOW CHART

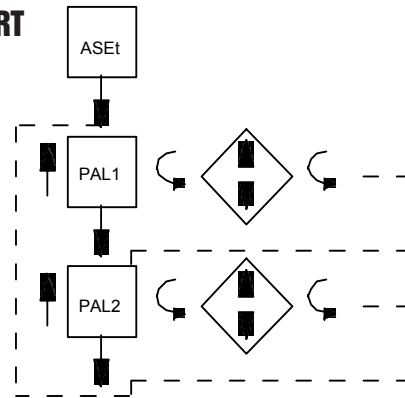

### TABLE 3-3 ALARM SET MODE CONFIGURATION PROCEDURE

Press and release the SCROLL key until **ASET** is displayed, then press the DOWN key. Press the SCROLL key to advance the display through the parameters and their values. Use the UP and DOWN keys to select (adjust) the values. After selecting a parameter, press the SCROLL key to proceed to the next parameter. Pen 1 selections will appear in the Pen 1 window and the Pen 2 (if provided) selections will appear in the Pen 2 window. After all selections have been made, press the UP key with a parameter in the display (not a setting) to exit the mode.

STEP	DESCRIPTION	DISPLAY AVAILABLE CODE	FACTORY SETTINGS	YOUR SETTING
1	Process Alarm 1	<b>PAL1</b>	-9999 to 9999 degrees/units	0
2	Process Alarm 2	<b>PAL2</b>	-9999 to 9999 degrees/units	0

If **ASET** does not appear on the display refer to the Enable mode section of this manual for directions on how to determine if the **ASET** mode is enabled. If **ASET** appears on the display, but pressing the DOWN key causes the display to change to **OFF**, this indicates that no alarm(s) have been selected in the Program mode.

#### ALARM OPERATION

There are two types available per pen, Process Direct or Process Reverse. These are selected in the Program mode.

Process Alarm Direct - the alarm will be ON if the process value is greater than the process alarm value selected in the Alarm Set mode.

Process Alarm Reverse - the alarm will be ON if the process value is less than the process alarm value selected in the Alarm Set mode.

The alarms will be active while the instrument is in the Operate mode.

Alarm output chatter can be reduced by using the hysteresis (adjusted in Program mode) to create a deadband around the alarm point.

#### LIMIT SETPOINT OPERATION

The instrument must be in the Operate mode to allow setpoint value to be displayed and adjusted. In the Operate mode, to view the setpoint, press and release the UP or DOWN key. The displayed value is the setpoint. To change the setpoint value, press and hold the appropriate key. Press and hold the UP key to increase the setpoint or press and hold the DOWN key to decrease the setpoint. The setpoint will change slowly at first then faster as the key is held.

To reset the limit output, press the RESET key after the limit condition has been cleared.



---

## Service 4.1

This section contains information regarding calibration and test procedures that can be performed in the field as well as items concerning the normal maintenance of the instrument.

---

## Changing Charts 4.2

Chart changes may be done while in the normal operating mode.

**CAUTION: The chart flange assembly pin is sharp to perforate the chart. Use caution while installing the chart to avoid coming into contact with the pin.**

1. Depress and hold the UP and DOWN keys for between 2 and 3 seconds. Immediately after depressing the keys, the unit will do a Lamp Test with all LED segments and indicators lighted on the upper (and lower) display.
2. After 2-3 seconds, the display will show **Cchg**, the pen(s) will move to and remain at a point above the top graduation on the chart and the chart will stop rotating. All other functions remain active (Operate, Display, etc).
3. Open the instrument door, snap up the chart hold down lever on the chart flange assembly, gently lift the pen(s) and remove old chart.
4. With the pen(s) held up, install new chart. Be sure to line up the chart time line so that the current time is aligned with the time setting mark on the chart platen.
5. Snap down chart hold down lever and close the instrument door.
6. Depress and hold the UP and DOWN keys for between 2 and 3 seconds. Immediately after depressing the keys, the unit will do a Lamp Test with all LED segments and indicators lighted on the upper (and lower) display.
7. After 2-3 seconds, the display will show **Cchg** momentarily, then the pen(s) position and chart rotation will be restored.

---

## Changing Pens 4.3

Open the instrument door. Refer to Figure 4-1 for pen changing procedure. This procedure is also provided on a label on the instrument chart platen. Be sure to replace the pen cartridge with the same type (color) that was removed. Be careful not to bend the pen arm while changing the pen.

---

**FIGURE 4-1**

Changing Pens

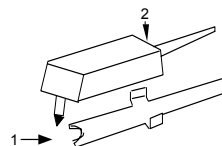

To install pen, slide pen into holder (1) and push down (2) as shown by arrows

For five replacement pens order:  
Green #60500401  
Red #60500402

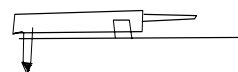

To remove pen for replacement, pull up at back end (1) and push out.

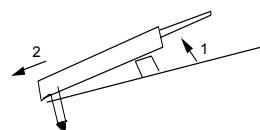

# Calibration 4.4

**CAUTION: Do not attempt any calibrations without the proper test equipment that meets or exceeds the specifications listed.**

Press and release the SCROLL key until **CAL** appears on the display, then press the DOWN key to enter the mode. The display will change to **CAL1**. Press the SCROLL key to advance the display to the other calibration modes available. For two pen units, **CAL2** and **CAL 3** will only need to be required on TB4 input. Both TB 4 and TB 5 inputs must be calibrated for RTD inputs if RTD's are used for input. Table 4-1, page 35, provides a listing of field calibration routines. All instruments are calibrated prior to shipment from factory.

## CALIBRATION FLOW CHART

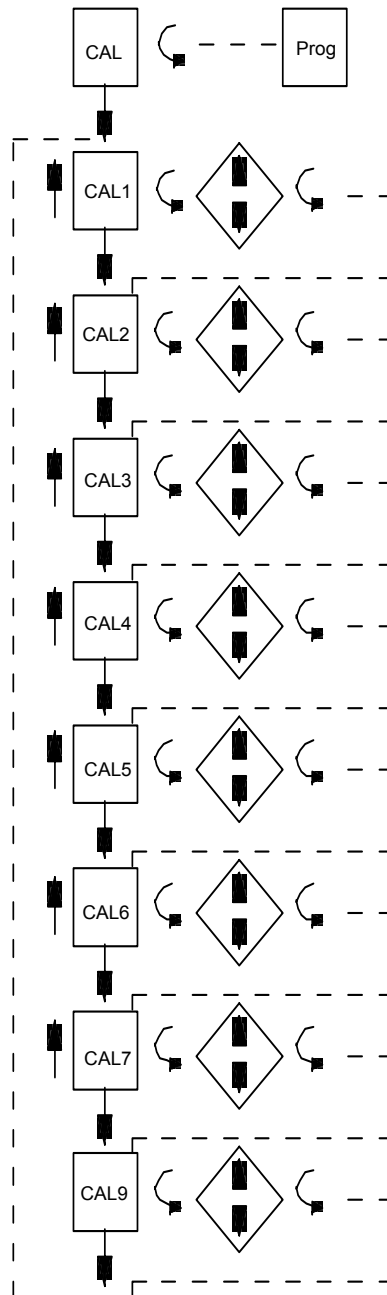

### KEY

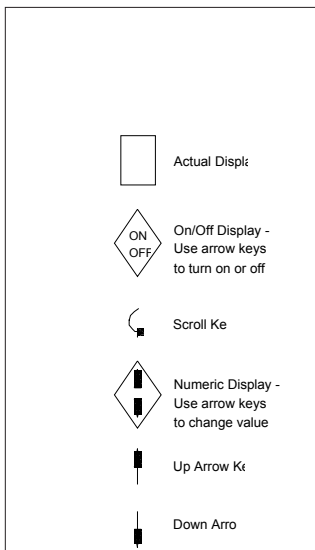

---

## TABLE 4-1 CALIBRATION PROCEDURES

Calibration Procedure	Description
CAL 1	Reinitialization of program and tuning values.
CAL 2	Main calibration necessary for all input types.
CAL 3	Cold Junction Compensation calibration used to correct for component variation in the CJC circuit. Necessary for thermocouple inputs.
CAL 4	Cold Junction Utility, displays temperature the cold junction compensator is sensing. No adjustment is made with this procedure.
CAL 5	RTD input calibration. Necessary to be performed on both terminal boards.
CAL 6	Cold Junction Compensation on/off. Used for validating thermocouple inputs with a millivolt source. (Non temperature compensating)
CAL 7	Factory use only.
CAL 9	Pen position calibration used to calibrate pens to chart.

---

### 4.4.1 CAL 1 PARAMETER RE-INITIALIZATION

This routine is used to clear all information in the Program and Alarm Set modes. All parameters will be reset to default values. **Before performing this procedure, make sure that the Program and Alarm values are written down so that they can be re-entered after Calibration 1 is completed. No test equipment required.**

With **CAL 1** displayed, while pressing the DOWN key, press the SCROLL key. The display will momentarily blank while the initialization is in progress. Upon completion of the routine, a Pen Home function is automatically performed; **P dn** is displayed during this period, with the decimal point flashing to indicate this mode. Once the pen(s) reach Pen Home, **CAL1** will be displayed.

---

### 4.4.2 CAL 2 MAIN CALIBRATION

This routine determines and saves calibration values which correct for component variations relating to the basic measuring function of the unit. A 50.00 mVDC  $\pm$  .01mVDC source is required for testing. **Make sure that the Processor board jumpers JU4 and JU5 are in the non-volt positions. See Appendix A-1 (page 50) for proper positioning. After completing CAL2, be sure to re-position these jumpers to the appropriate position for your input.**

With **CAL 2** displayed, press and hold the DOWN key, then press the SCROLL key. Release the keys when the instrument displays **hLd1**. Short the input terminals or apply 0.00,  $\pm$ .01 mVDC to TB 4 terminals 1 and 2. Press the DOWN key and **dELy** will appear for 10 seconds, then **SCAn** will appear for 10 seconds. A calibration reference number will then appear, this should be 0  $\pm$  50. If this number falls outside these limits, press the SCROLL key and **CAL 2** will be displayed. Perform the calibration again. Repeat the calibration until the number falls within the tolerance limits. If the number remains outside the limits, check the connections and try the calibration again. If the number does not approach the tolerance limits contact the nearest representative or the factory for assistance. With an acceptable reference number on the display, remove the short and connect a 50.00,  $\pm$ .01 mVDC source to the TB 4 terminals 1 and 2. Be sure to observe the proper polarity when connecting the source. Terminal 1 is positive and terminal 2 is negative. Press the DOWN key, **deLy** will be displayed for 10 seconds and then **SCAn** for 10 seconds. When the calibration is complete **CAL 2** will reappear.

(Continued on next page)

Error recovery:

See section 4.6 (page 43) for details. Insure that the millivolt source is connected correctly and functioning properly.

The calibration can be exited when **hLd1** or the calibration reference number is displayed by pressing the SCROLL key.

#### **CAL2 QUICK CALIBRATION**

This routine will allow the operator to execute a rough calibration on their unit via the keypad with no other equipment or disturbance to established wiring. It is intended to provide a partial recovery from a calibration corruption where the necessary equipment indicated may not be available. It should be noted that this is not intended as a substitution to the main calibration procedure described earlier and may considerable deter from the accuracy of the instrument.

With **CAL2** displayed, press and hold the DOWN ARROW key, then press the SCROLL key. Release both keys and the instrument will display **hLd1**. Press and hold the UP ARROW key, then press the SCROLL key. The display will momentarily blank and then **CAL1** will be displayed. Release both keys and depress the UP ARROW key. **CAL** will be displayed.

---

#### **4.4.3 CAL 3 COLD JUNCTION COMPENSATION**

This routine determines and saves calibration values which correct for component variations relating to the cold junction compensation. This calibration must be preceded by **CAL 2** the main calibration, to properly calibrate the instrument. These two calibrations are all that is needed for proper operation with thermocouple inputs

Test equipment: 1-type J thermocouple  
1-mercury thermometer +/- .25 degrees F for equivalent  
Allow 30 minutes of warm up time for the instrument with the thermocouple connected before proceeding with calibration.

Operation:

With **CAL 3** displayed press and hold the DOWN key, then press the SCROLL key . Release both keys and the instrument will display **hoLd**. Connect the J thermocouple to TB 4 terminals 1 and 2 and place the thermometer inside the case at the bottom of the instrument. Press the DOWN key , **deLy** will be displayed for to 10 seconds, then **SCAn** for 10 seconds. The display will be the temperature to the nearest tenth of a degree C. Compare the display reading with thermometer and use the UP and DOWN keys to correct the reading. To exit press the SCROLL key and **CAL 3** will be displayed again.

If the display stays in **SCAn** for more than 10 seconds press the SCROLL key. CAL3 should be displayed. With CAL3 displayed, while pressing the DOWN key, press the SCROLL key. The instrument will display **hoLd**. Press the UP key and this will store a default calibration value and proceed to **dELy** as described .

Error recovery:

See section 4.6 (page 43) for details on specific errors. The calibration can be exited if **hoLd** or the CJC temperature is displayed by pressing the SCROLL Key.

---

#### **4.4.4 CAL 4 COLD JUNCTION UTILITY**

This procedure displays the temperature the cold junction compensator is sensing. No test equipment is required.

With **CAL 4** displayed press and hold the DOWN key, then press the SCROLL key . Release both keys and **SCAn** will be displayed for 10 seconds while the instrument senses the CJC temperature. The result will then be displayed to a tenth of a degree C. The input terminals must be shorted. **CAL 3** must first be performed. ***The displayed temperature is not the ambient temperature. It is the temperature of the CJC .*** To exit, press the SCROLL key and **CAL 4** will be displayed.

---

#### 4.4.5 CAL 5 RTD INPUT

This procedure determines and saves calibration values relating to RTD inputs. This calibration must be preceded by **CAL 2** to properly calibrate the instrument. Both RTD inputs must be calibrated and both inputs must have valid inputs during the calibration. Decade boxes with .01% resolution or equivalent are required. **Make sure that the Processor board jumpers JU4, JU6 and JU5, JU7 are in the proper positions. See Appendix A-1 (page 50).**

With **CAL 5** displayed, press and hold the DOWN key and then press the SCROLL key. The display will now be **PEn1** to indicate that the instrument is set to calibrate the RTD input on TB 4. Press the DOWN key to change the display to **PEn2** to calibrate the RTD input at TB 5. Choose the input TB to be calibrated and press the SCROLL key, **hLd1** will then be displayed. Connect the decade box at 100 ohm setting across the input terminals 1 and 2 and a jumper wire from terminal 2 to 3. Press the DOWN key and **dELy** will be displayed for 10 seconds, then **SCAn** for ten seconds. When **hLd2** is displayed, change the decade box setting to 277 ohms to the input terminals (do not disturb the wiring) and press the DOWN key. The display will change to **dELy** for 10 seconds, followed by **SCAn** for ten more seconds. **CAL 5** will be displayed after the calibration is completed. To exit the calibration mode properly, with **CAL5** displayed, press the UP key twice. To continue to another calibration, press the SCROLL key with **CAL5** displayed.

##### Error recovery:

See section 4.6 (page 43) for details on specific errors.

The calibration can be exited when the instrument displays **hLd1** by pressing the SCROLL key.

---

#### 4.4.6 CAL 6 COLD JUNCTION UTILITY

This routine provides selection of operating modes for the cold junction compensation used for thermocouple inputs.

With **CAL 6** displayed, press and hold the DOWN key, then press the SCROLL key. The instrument will display **C6** and the number of the mode in effect. Press the UP or DOWN key to change the mode selection, indicated by the number to the right of the **C6**. Pressing the SCROLL key will exit the calibration with the last mode number displayed in effect.

The selected mode will remain in effect if power is interrupted. To return the instrument to normal operation, **CAL 6** must be exited, with mode zero selected, or **CAL 1** must be executed to initialize all parameters.

Mode 0: Normal operating mode.

Mode 1: Cold Junction Compensation temperature will be internally fixed at 0 degrees C by the software to facilitate linearization testing when using an uncompensated millivolt source to simulate the thermocouple millivolt input signal.

## 4.4.7 CAL 9 PEN CALIBRATION

This procedure is used to calibrate the pen(s). No special test equipment required.

Valid inputs must be connected to TB 4 and TB 5 before performing this calibration. With **CAL 9** displayed, push and hold the DOWN key, then press the SCROLL key. Release both keys and the display will indicate **PEn1**. For 2 Pen instruments, press the DOWN key to toggle the display between pen 1 and pen 2. With desired pen displayed, press the SCROLL key.

### FOR INSTRUMENTS WITH SOFTWARE REVISION R2.99 AND BELOW:

**dELY** will be displayed as the pen selected moves toward the center chart hub. **PEnL** will be displayed; use the UP and/or DOWN keys to adjust the pen to the low end or 0% of the chart. When adjusted, press the SCROLL key, **SCAn** will appear for 10 seconds and the pen location value will be saved in memory. Next **dELY** will appear as the pen moves to the outer edge or, 100% mark on the chart. **PEnh** will appear, use the UP and/or DOWN keys to adjust the pen position to the proper 100% of chart position. Press the SCROLL key and **SCAn** will be displayed as the pen position value is saved. Then **dELY** will be displayed as the pen moves to about mid-scale. **CAL9** will be displayed showing that the calibration is complete. When the calibration is complete, with **CAL9** displayed, press the UP key twice to properly exit the calibration mode. CAL9 can now be repeated on the other pen of a 2 pen instrument or another routine can be selected.

### FOR INSTRUMENT WITH SOFTWARE REVISION R3.00 AND ABOVE:

**P.dn** will be displayed while the selected pen is moved to its "HOME" position (toward the chart hub) with the decimal point flashing to indicate this mode. Once "Pen Home" is found, the pen will move to the inner ring and **PEnL** will be displayed. At this point, one of two adjustments may be made; Pen Arc or Zero and Span.

Pen Arc - To adjust the pen arc, the UP and DOWN keys are pressed simultaneously to draw an arc for visual reference. The display will show **P uP** while the selected pen moved upscale to the top stop position. The pen then moves back downscale to nominally place the pen at the outer ring (100%) of the chart. The display will now display **Arc**.

The pen arm may be loosened and the length adjusted to a position and angle to place the pen tip near the outer ring then re-tighten the pen arm. Press any key and the pen will drive to "HOME", then back to the inner ring (0%) and **PEnL** will be displayed.

Zero and Span - To begin a pen zero, with **PEnL** in the display, the UP or DOWN key may be pressed to move the pen to the low end of the chart span (0%). When adjusted, press the SCROLL key and **P uP** is displayed while the pen is moved to the outer edge (100%) of the chart, then **PEnh** is displayed. To adjust pen span, use the UP and DOWN keys to adjust the pen for the high end (100%) of the chart. When adjusted, press the SCROLL key and **P dn** will be displayed for about 5 seconds while the pen is moved to the 50% point on the chart, then **PEn1** is displayed. Calibration may now be performed again to verify the accuracy, or press the UP key twice to exit back to the CAL mode.

# Test Mode 4.5

To enter the Test mode, press and release the SCROLL key until **tESt** appears on the display then press the DOWN key. **tSt1** will be displayed, press and release the SCROLL key to advance the display to the desired test. Tests 1, 2 and 3 are performed as a unit so the display will advance directly to **tSt4** from **tSt1**. Listed in Table 4-2, page 40, are the test procedures available. Test 1, 2 and 3 are performed on start up, periodically during operation, and on entry into the Test mode. Test 4 is executed on entry into and periodically during the Operation mode. These tests can be used as a trouble shooting aid.

## TEST MODE FLOW CHART

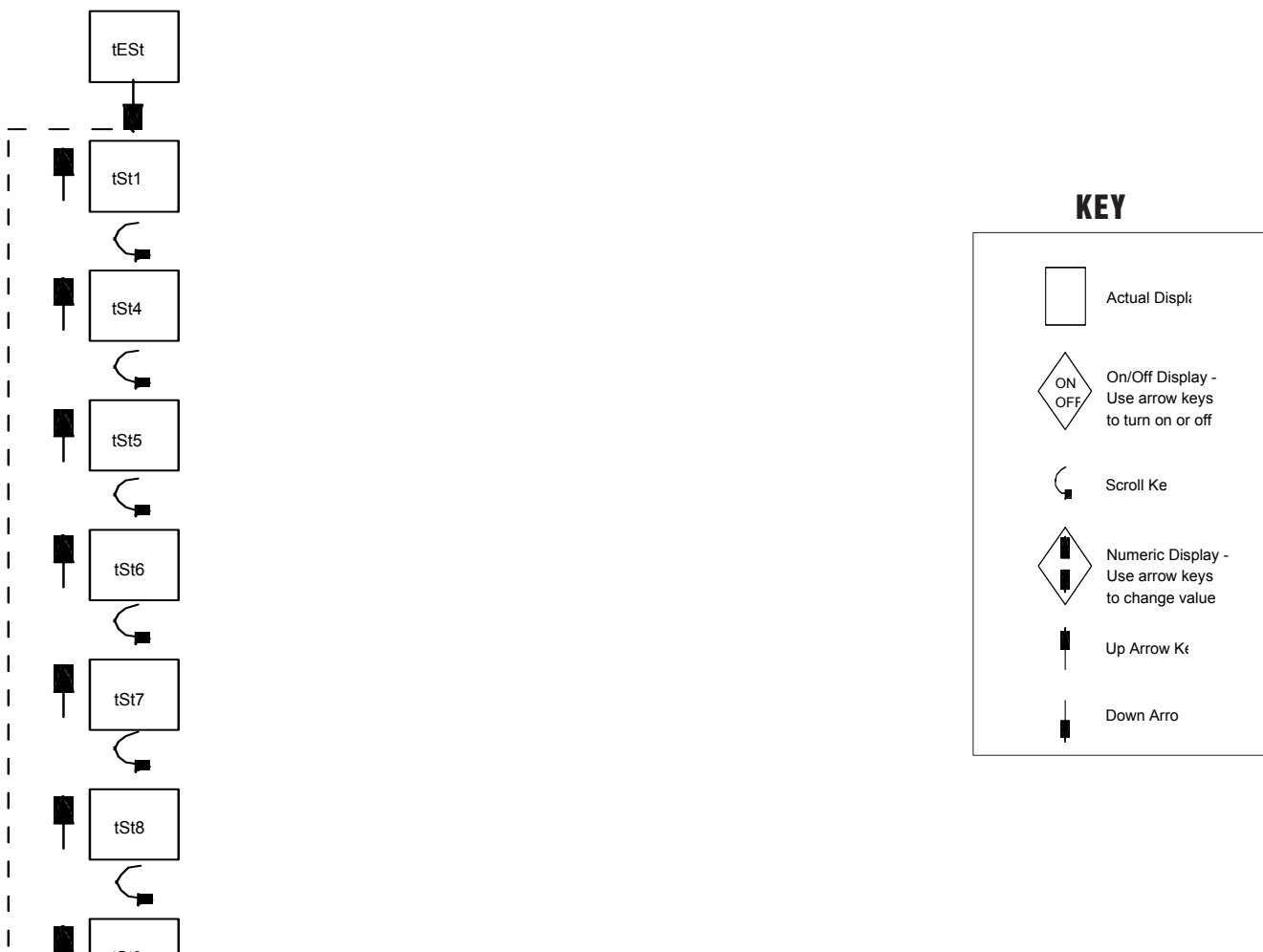

---

## TABLE 4-2 TEST PROCEDURES AND DESCRIPTION

Test	Description
Test 1	Microprocessor internal RAM test. Used to check the processor RAM to make sure it is functioning correctly.
Test 2	External RAM test, used to test the RAM chip for proper function.
Test 3	EPROM checksum test, used to check that the EPROM program is correct.
Test 4	External RAM checksum test; instrument test and identifies how many times Errors16 or 17 have occurred.
Test 5	Verifies that all keys are functional and all LEDs are working.
Test 6	Used to verify that all relays and solid state relay driver outputs are working correctly.
Test 7	This procedure will allow operator to adjust the current output value to check the output and to test the operation of the external device.
Test 8	Pen and chart motor operational check.
Test 9	Verifies that the auxiliary inputs are functioning properly.
Test A	Communications Hardware Test.

---

### 4.5.1 TEST 1 INTERNAL RAM TEST

Tests the Random Access Memory internal to the microprocessor. No special test equipment is required.

With **tSt1** displayed, press and hold the DOWN key, then press the SCROLL key. **tSt1** will be displayed momentarily while the test is in progress. Upon successful completion, the instrument will proceed to Test 2.

---

### 4.5.2 TEST 2 EXTERNAL RAM TEST

Tests the battery backed-up RAM external to the microcomputer. No special test equipment is required.

After completion of Test 1, **tSt2** will be displayed momentarily while the test is in progress. Upon successful completion, the instrument will proceed to Test 3.

---

### 4.5.3 TEST 3 PROGRAM EPROM TEST

This is a checksum test to verify data integrity of the stored program. No special test equipment is required.

After completion of Test 2, **tSt3** will be displayed momentarily while the test is in progress. Upon successful completion of Test 3 **tst1** will be displayed.

---

### 4.5.4 TEST 4 EXTERNAL RAM CHECKSUM TEST

This is a checksum test to verify the integrity of data stored in RAM and indicate the number of times the instrument has had an Error 16 or 17. The unit may have automatically recovered from these errors. No special test equipment is required.

With **tst4** displayed, press and hold the DOWN key then press the SCROLL key. The display will blank momentarily, then momentarily display two numbers, and then **tst4** will be displayed. These numbers indicate the number of times Error 16 and 17 have occurred respectively. Test 4 can be executed again, or another test may be selected.



---

### 4.5.5 TEST 5 KEYPAD/DISPLAY TEST

This test allows the operator to verify that the keys work and that all display elements can be lighted. No special test equipment is required.

With **tSt5** displayed, press and hold the DOWN key, then press the SCROLL key and then release both keys. The display will go blank. The following code will be displayed while the corresponding key is pressed:

<u>Key</u>	<u>Display</u>
SCROLL	<b>SCrL</b>
UP	<b>uAro</b>
DOWN	<b>dAro</b>
RESET (upper)	<b>Autu</b>
RESET (lower)	<b>AutL</b>
UP and DOWN	<b>(All LED's and segments lit)</b>
SCROLL and UP	<b>(exit)</b>

To exit, press the SCROLL and UP keys simultaneously, **tSt5** will be displayed.

---

### 4.5.6 TEST 6 RELAY/ SOLID STATE RELAY DRIVER OUTPUT TEST

Allows the operator to verify that the Relay and /or the Solid State Relay Driver output(s) are working. A volt/ohm meter will be required to test the output.

With **tSt6** displayed, press and hold the DOWN key, then press the SCROLL key. **oFF** will be displayed. For SPST Relay outputs, connect the meter across the relay output in the ohm scale. For SPDT Relay outputs, connect the meter across the N.O. and COM output in the ohm scale. The meter should read continuity with the relay on and infinity when the relay is off. For SSR Driver outputs, connect the meter across the output in the Volt DC scale. The meter should read 5 VDC when the SSR driver is on and 0 VDC when the driver is off. Press and release the DOWN key to advance through the following sequence:

<u>DISPLAY</u>	<u>RELAY ON SPST</u>	<u>RELAY ON SPDT</u>
<b>rLYA</b>	A	A
<b>rLYb</b>	B	B
<b>rLYC</b>	C	C
<b>rLYd</b>	D	D
<b>rLYE</b>	E	None
<b>rLYF</b>	F	None
<b>rLYg</b>	G	G
<b>rLYH</b>	H	H
<b>oFF</b>	None	None

To exit, press the SCROLL key and **tSt6** will be displayed. **The existence of Relay and Solid State Relay Driver output(s) is dependent upon the hardware configuration.**

---

### 4.5.7 TEST 7 CURRENT OUTPUT TEST

This test allows the operator to verify that the current output(s) are functioning properly or will allow the selection of an output value for testing of associated equipment. A milliamp meter is required for testing.

With **tSt7** displayed press and hold the DOWN key, then press the SCROLL key. The display will indicate **CurA**, for the first current output. By pressing the DOWN key, the instrument will advance through the selection sequence of **Curb**, **CurC**, **Curd**, and then back to **CurA**. Choose the desired output to be tested and connect the milliamp meter across the output terminals being tested. Be sure to observe the proper polarity when connecting the meter. Terminal 1 is positive and terminal 2 is negative. Press the SCROLL key and the display will indicate 4 milliamps. Use the UP and/or DOWN key to increase or decrease the current output in 1 mADC steps from 0 to 20 mADC. (Continued on next page)

The current output reading should be  $\pm 0.1$  mADC at any output value. A  $\pm 5\%$  of span adjustment for the current output(s) is provided by using the potentiometer adjacent to the current output on the Current Output board. See Appendix A-4 (page 53). To exit the test, press the SCROLL key and **tSt7** will be displayed. **The existence of a mADC current output is dependent upon the hardware configuration.**

---

#### 4.5.8 TEST 8 PEN/CHART MOTOR TEST

This test allows the operator to verify that pen and chart motors are functioning properly. No special test equipment is required.

With **tSt8** displayed press and hold the DOWN key, then press the SCROLL key. The display will show **ALL** while the test is in progress. This test functions automatically. The chart speed will be at maximum, 72 seconds per revolution. Starting at the current pen position, pen 1 will move (sweep) upscale for about 5 seconds, then downscale for about 5 seconds. Pen 2 (if provided) will sweep in the opposite direction. The pens will continue to cycle until the test is exited. To exit, press the SCROLL key. The display will show **tSt8**.

---

#### 4.5.9 TEST 9 AUXILIARY INPUT TEST

This test allows the operator to verify that the pen position feedback input(s) are functioning properly. With **tSt9** displayed, press and hold the DOWN key, then press the SCROLL key. The display will show **Ai1**, Auxiliary Input 1. By pressing the DOWN key the instrument will sequence through the selections for testing: **AF1**, **Ai2**, **PF2**, then back to **Ai1** (PF=Pen Feedback). With the desired input selected, press the SCROLL key. The corresponding value will be displayed. For software revision R2.99 and below only, the pen position feedback input voltage will be displayed to the nearest tenth of a millivolt. Manually move the pen up and down scale and verify that the displayed reading changes from about 0 to 50 millivolts. For software revision R3.00 and above, the pen position feedback input voltages are disabled and will display a fixed value of zero. To terminate a particular test, press the SCROLL key. The display will show **tSt9**.

---

#### 4.5.10 TEST A COMMUNICATIONS HARDWARE TEST (COMMUNICATIONS OPTIONAL)

This test allows the operator to verify that the communications hardware is functioning properly.

With **tStA** displayed, press and hold the DOWN key then press the SCROLL key. The display will indicate **SEnd**. Press the DOWN key to toggle the display between **SEnd** and **rEC**. With the desired function selected, press the SCROLL key. In the **SEnd** (send or transmit) mode, the instrument will repeat the following sequence. First the transmitter will output a logic 1 on the line for one second. Next the transmitter will change the logic level to 0 for one second. Then the transmitter will disable for one second. In the **rEC** (receive) mode, the transmitter is continuously disabled. In either mode, the instrument will monitor the line and display **rEC1** when a logic 1 is on the line or **rEC0** when a logic 0 is on the line. In the **SEnd** mode, the instrument will display **rEC** when the transmitter is disabled. To perform an internal test and verify the basic operation of the hardware, place the instrument in the Send mode and verify that the display cycles through **rEC1**, **rEC0**, and **rEC**. To verify that the transmitter functions properly, two LED's, each with a current limiting resistor, can be connected with opposite polarity observed to the TB 2 terminals 1 and 2.

The following three states should be observed: one LED on, then the other LED on, then both off. Alternately, a load resistor can be placed on the terminals, and observe that the voltage generated across the load resistor is as follows:  $>+3$  VDC, then  $>-3$  VDC, and then 0 VDC. Another method, to test the communications hardware, would be to connect one or more instruments in the Receive mode to an instrument in the Send mode. All of the instruments in the Receive mode should have their displays alternating in sync with the instrument in the Send mode. When the sending instrument displays **rEC**, the receiving instruments should display **rEC1**. To terminate the test, press the SCROLL key for one second. Upon exit, **tStA** will be displayed. **The existence of the communications hardware is dependent on the hardware configuration.**

---

## Trouble-shooting and Diagnostics 4.6

The Trouble-shooting Guidelines Section consists of two columns. The first column is a list of some possible instrument conditions. The second column is a list of steps that should improve the condition. The steps should be performed in order until the condition improves or all the steps have been completed. If the instrument condition has not improved, contact the nearest representative or the factory for assistance.

Trouble-shooting should be performed by qualified personnel using the proper equipment and following all safety precautions. Whenever possible the trouble-shooting should be accomplished with the electrical power disconnected. The instrument contains static sensitive components so care should be taken to observe anti-static procedures.

### **CONDITION**

**Display(s) is/are blank**

### **CORRECTION STEPS**

1. Verify that the correct instrument power, as indicated on the wiring label on the platen, is supplied to TB 1 terminals 1 & 2. Check the position of the power select switch, on 230 VAC models, correctly indicates the power that is connected to the instrument. If the switch does not indicate the correct voltage, reposition as necessary. If the voltage is not correct, check the power source.
2. Turn off the instrument power. Wait about 5 seconds then turn the power on again.
3. Turn off the instrument power, open the cover, loosen the platen hold down screw, and swing the platen out of the way. Inspect the instrument for poor connections.
  - a. The white ribbon cables that connect the Processor board (Appendix A-1, page 50) to the platen must be properly aligned and seated in the sockets.
  - b. The display board(s) white ribbon cable(s) pins should be properly aligned and seated in the sockets on the platen board.
  - c. Inspect the EPROM (U7), RAM (U8) and microprocessor chips (U5) to see that the legs are properly seated in their sockets on the Processor Board (page 50).
  - d. Close the platen and tighten the hold down screw. Close the cover and turn on the power to see if the display(s) will now light.
4. Turn off the instrument power. Press and hold the UP and DOWN keys. Turn on the power. Hold the keys pressed for about 10 seconds. If the display(s) light the model number, Program and Alarm Set mode parameters will need to be re-entered (pages 28 thru 32 or Software Ref. Sheet, page 59, if already filled out).

---

**Model Number Displayed during power up is incorrect**

1. Turn off the instrument power, wait 5 seconds then reapply the power. Verify that the number displayed during the power up sequence is the same as indicated on the label affixed to the platen. If the number displayed is incorrect perform the following steps:
  - a. Turn off the power to the instrument. Press and hold the UP and DOWN keys. Turn on the power and keep the keys pressed until the model number displayed resets to **71X0-0000-0X21** where the digits X are determined by the firmware installed. Release the keys and turn off the power.
  - b. To enter the correct model number, press and hold the SCROLL and DOWN keys and turn on the instrument power. **71X0** should be displayed. Wait about 5 seconds and release the keys. The display should stay **71X0**. Use the UP/DOWN keys as necessary to change the displayed number to match the first 4 digits of the model number as indicated on the label on the platen. After adjusting the first 4 digits to the proper values, press the SCROLL key and the display will change to **0000**. Use the UP/DOWN keys to set the next 4 digits of the model number to the correct values. Press the SCROLL key and the display will be **0X21**. Use the UP/DOWN keys as necessary to adjust the last 4 digits of the number. Press the SCROLL key and the power up sequence will complete. The Program and Alarm Set mode parameters will need to be re-entered (pages 28 thru 32 or Software Ref. Sheet, page 59, if already filled out).

---

**Relay/SSR Driver Malfunction**

1. Verify that the Program and Alarm Set mode parameters are correctly set (pages 28 thru 32 or Software Ref. Sheet, page 59, if already filled out).
2. Turn off the power to the instrument. Wait about 5 seconds and turn the power on again. Confirm that the model number displayed during the power up sequence indicates that the output(s) is/are present in the instrument. See Appendix C (page 55) for the model number explanation/decoding. This number should match the number on the label affixed to the platen.
3. Turn off the power to the instrument. Open the cover. Loosen the platen hold down screw and swing the platen open. Inspect the instrument Relay/SSR Driver board (See Figure 2-4, page 9) for the presence of the output device(s). A relay output will appear to be a cube. The SSR Driver will appear as a resistor and a jumper wire. The output will not work if the hardware is not present. Inspect that the output terminal connections are present and firmly attached.
4. Check the output(s) operation by performing Test 6 as described in the Test section (page 41). If the output(s) function in the Test mode re-examine the Program and Alarm Set mode parameters settings (pages 28 thru 32 or Software Ref. Sheet, page 59, if already filled out).

- If the output appears not to turn off remove the power to the instrument. Open the cover and loosen the platen hold down screw. Swing the platen open. Clip the resistor located on the Relay Board adjacent to the output(s) that seem to stay on (See Appendix A-2, page 51). A .01 microfarad, 1 KV capacitor should be connected from the terminal listed below, for the output where the resistor indicated was removed, to the AC ground.

Relay A	R1	TB 6	Terminal 1
Relay B	R2	TB 6	Terminal 3
Relay C	R3	TB 7	Terminal 1
Relay D	R4	TB 7	Terminal 3
Relay E	R5	TB 8	Terminal 1
Relay F	R6	TB 8	Terminal 3

Close the platen and tighten the hold down screw. Close the cover and turn the power on to the instrument. Check the operation of the output(s).

#### **mADC Output(s) Malfunction**

- Verify that the Program mode parameters are correctly set (page 28).
- Turn Off the power to the instrument. Wait about 5 seconds and turn the power on again. Confirm that the model number displayed during the power up sequence indicates that the output(s) is/are present in the instrument. See Appendix C ( page 55) for the model number explanation/decoding. This number should match the number on the label affixed to the platen.
- Turn off the power to the instrument. Open the cover. Loosen the platen hold down screw and swing the platen open. Inspect the instrument Current Output board (See Figure 2-6, page 14) for the presence of the output device(s). The output will not work if the hardware is not present. Inspect that the output terminal connections are present and firmly attached. Close the platen and tighten the hold down screw. Close the cover and turn on the power.
- Refer to the Test section and carry out the procedure for the Current Output(s) Test 7 (page 41). If the current output operates properly in the Test mode re-check the Program mode parameters (page 28 or Software Ref. Sheet, page 59, if already filled out).

#### **Pen(s) do not operate**

- Verify that the Program mode parameters are properly set (page 28 or Software Ref. Sheet, page 59, if already filled out)
- If the process value in the display exceeds the chart upper or the chart lower values selected in the Program mode the pen will appear stuck at the chart upper or lower edge respectively. Re-configure values as needed by the application (May require a new chart).
- Perform Test 8 as described in the Test section of the manual (page 42). If the pen(s) operate in Test 8, perform the pen calibration, Cal 9, as described in the Calibration section of the manual (page 38). Return the instrument to the **oPEr** and check the operation of the pen(s).

(Continued on next page)

4. For software revision R2.99 and below, perform Test 9 as described in the Test Section of the manual (page 42). If the pen feedback voltage does not vary, check the pen Potentiometer Segment board for proper ribbon cable connection to the Processor board (Appendix A-1, page 50) and that the pen position fingers are making contact with Potentiometer Segment board.
5. For software revision R2.99 and below, inspect to see that the Potentiometer Segment of the pen feed back is clean. Use a non-residue type cleaner that does not affect the plastic to clean the segment if necessary.
6. Verify the instrument is not in Change Chart function.

---

## ERROR CODE DISPLAYED

---

**SnSr** - Sensor Break or Over Range

1. Inspect the sensor for proper operation and connection to the instrument. Acceptable sensor ranges for the instrument are listed in the Specifications section of Appendix D (page 56).
2. Verify that the Program mode input selection matches the sensor input connected (page 28 or Software Ref. Sheet, page 59, if already filled out).
3. Check that the input conditioning jumpers on the Processor board (Appendix A-1, page 50) are in the proper position for the sensor input. Check that the jumpers are in the proper position for the Terminal Board where the sensor is connected.
4. Perform the calibration procedure(s), as described in the Calibration section (page 35), for the sensor input type.

---

**Hi** - Input more than 10% Over Span

1. Perform the steps listed for the **SnSr** Error Condition. (page 46)

---

**Lo** - Input more than 10% Under Span

1. Perform the steps listed for the **SnSr** Error Condition. (page 46)

---

**6̄** - display overranged (the "broken 6" appears on the left segment of the display)

1. If this error code is displayed as a Program or Alarm Set mode parameter perform the CAL 1 procedure as described in the Calibration section of the manual (page 35).
2. If this error code appears as part of the model number during the power up sequence, follow the steps listed for the "Model Number is not correct" condition (page 44).
3. If this error appears, check the Program mode parameter **dPos**, if not 0, change to 0 and see if the error clears.

---

**Er 1** - Microprocessor RAM Failure

1. Turn off the power to the instrument. Wait 5 seconds, and turn the power on.
2. Turn off the power to the instrument. Open the cover, and loosen the platen hold down screw. Swing open the platen and inspect that the microprocessor chip is properly seated in the socket located on the Processor board (Appendix A-1, page 50). Close the platen and tighten the screw. Close the cover and turn on the power.

<b>Er 2</b> - External RAM Failure	<ol style="list-style-type: none"> <li>1. Turn off the power to the instrument. Wait 5 seconds, and turn the power on.</li> </ol>
<b>Er 3</b> - EPROM Checksum Failure	<ol style="list-style-type: none"> <li>1. Perform the steps listed for <b>Er 1</b> except that the EPROM (U7) on the Processor board should be inspected.</li> </ol>
<b>Er 4</b> - RTD Mismatch Error	<ol style="list-style-type: none"> <li>1. Check the connections to the instrument for the RTD Input Calibration (CAL5) as described in the Calibration section (page 37). Repeat the RTD Input Calibration.</li> </ol>
<b>Er 5</b> - No Zero Crossings Detected	<ol style="list-style-type: none"> <li>1. Turn off the power to the instrument. Wait 5 seconds, and turn the power on.</li> <li>2. Connect the instrument to another AC power source.</li> </ol>
<b>Er 6</b> - AC line below 43 HZ	<ol style="list-style-type: none"> <li>1. Turn off the power to the instrument. Wait 5 seconds, and turn the power on.</li> <li>2. Connect the instrument to another AC power source.</li> </ol>
<b>Er 7</b> - AC line over 64 HZ	<ol style="list-style-type: none"> <li>1. Turn off the power to the instrument. Wait 5 seconds, and turn the power on.</li> <li>2. Connect the instrument to another AC power source.</li> </ol>
<b>Er 8</b> - Cal 2 Volt Input Error	<ol style="list-style-type: none"> <li>1. Check that 50 mVDC is properly connected to the instrument and is within the tolerance limits as indicated in the CAL2 procedure of the Calibration section (page 35).</li> <li>2. Turn off the power to the instrument and open the cover. Loosen the platen hold down screw and swing the platen open. Inspect the Processor board (Appendix A-1, page 50) to insure that the input conditioning jumper JU4 is in the non-volt position. The jumper must be in the non-volt position to perform the CAL 2 procedure properly. Close the platen and tighten the hold down screw. Close the cover and turn on the power to the instrument.</li> <li>3. Perform the CAL2 procedure as described in the Calibration section (page 35).</li> </ol>
<b>Er 9</b> - ADC Reference Number Error	<ol style="list-style-type: none"> <li>1. Perform the CAL2 procedure as described in the Calibration section (page 35).</li> </ol>
<b>Er10</b> - ADC Reference Voltage Error	<ol style="list-style-type: none"> <li>1. Perform the CAL2 procedure as described in the Calibration section (page 35).</li> </ol>
<b>Er11</b> - Cold Junction Compensation Error	<ol style="list-style-type: none"> <li>1. Perform the CAL3 procedure as described in the Calibration section (page 36).</li> </ol>



<b>Er12</b> - CAL2 Voltage Error	<ol style="list-style-type: none"> <li>1. Check that 50 mVDC is properly connected to the instrument and is within the tolerance limits as indicated in the CAL2 procedure of the Calibration section (page 35).</li> <li>2. Turn off the power to the instrument and open the cover. Loosen the platen hold down screw and swing the platen open. Inspect the Processor board (Appendix A-1, page 50) to insure that the input conditioning jumper JU4 is in the non-volt position.</li> <li>3. Perform the CAL2 procedure as described in the Calibration section (page 35).</li> </ol>
<b>Er13</b> - RTD CAL5 Input Error	<ol style="list-style-type: none"> <li>1. Check that resistance device is of the correct value and properly connected to the instrument and is within the tolerance limits as indicated in the CAL5 procedure of the Calibration section (page 37).</li> <li>2. Turn off the power to the instrument and open the cover. Loosen the platen hold down screw and swing the platen open. Inspect the Processor board (Appendix A-1, page 50) to insure that the input conditioning jumpers are in the correct position for the RTD input for the Terminal Board being calibrated. For TB 4, JU4 should be in the non-volt position and JU6 in the RTD position. For TB 5, JU5 should be in the non-volt position and JU7 in the RTD position.</li> <li>3. Perform the CAL5 procedure as described in the Calibration section (page 37).</li> </ol>
<b>Er14</b> - Cold Junction Compensation Error	<ol style="list-style-type: none"> <li>1. Perform the CAL3 procedure as described in the Calibration section (page 36).</li> </ol>
<b>Er15</b> - Ground Reference Tolerance Error	<ol style="list-style-type: none"> <li>1. Perform the CAL2 procedure as described in the Calibration section (page 35).</li> </ol>
<b>Er16</b> - Program/ASEt Mode Checksum Error	<ol style="list-style-type: none"> <li>1. Record all Program and <b>ASEt</b> mode parameters. Perform CAL 1 procedure as described in the Calibration section (page 35). Re-enter the Program and <b>ASEt</b> mode parameters.</li> </ol>
<b>Er17</b> - Calibration Checksum Error	<ol style="list-style-type: none"> <li>1. Perform the calibration procedures that are needed for the input sensors that will be used (page 35).</li> </ol>
<b>Er21</b> - Pen Feedback Error	<ol style="list-style-type: none"> <li>1. Perform the steps listed for pens not moving.</li> </ol>
<b>Er36</b> - Incorrect Crystal For Digital Comm.	<ol style="list-style-type: none"> <li>1. Turn off the power to the instrument, wait 5 seconds, then turn the power on.</li> </ol>
<b>Er37</b> - Incorrect Micro. For Digital Comm.	<ol style="list-style-type: none"> <li>1. Turn off the power to the instrument wait 5 seconds, then turn the power on.</li> </ol>
<b>Er38</b> - Incorrect RAM for profiler	<ol style="list-style-type: none"> <li>1. Turn off the power to the instrument, wait 5 seconds, then turn the power on.</li> <li>2. Re-configure for non-profiler.</li> </ol>



---

<b>Momentary ER 70 -</b> Controller unable to respond within 250 milliseconds	1. May occur when incrementing or decrementing a value. Error clears itself.
<b>Momentary ER 71 -</b> Byte received before the response was transmitted	1. Computer program must wait longer for a response from the instrument.
<b>Momentary Er 72 -</b> Incorrect Block Check character was received	1. Data received not valid, possible corruption on the comm line. Possible noise problems. Check baud rates, instrument addresses, line connections, and termination.
<b>Momentary Er 73 -</b> Byte received with incorrect parity.	1. Check baud rate. 2. Possible noise problems. Check instrument addresses, line connections, and termination.

---

# Appendix A

## Board Layout - Jumper Positioning

FIGURE A-1 - PROCESSOR BOARD

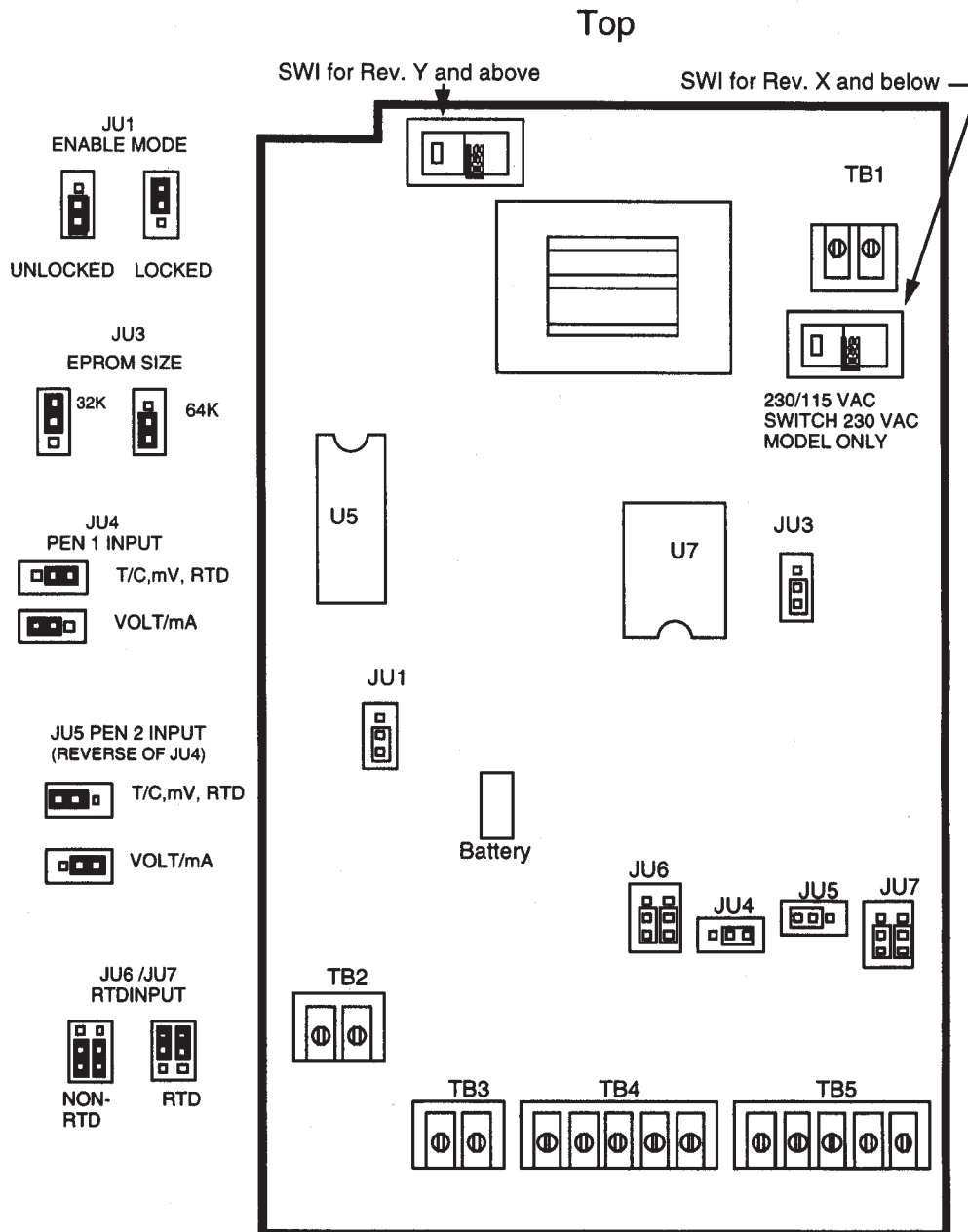

**FIGURE A-2 - SPST RELAY/SSR DRIVER OUTPUT BOARD**

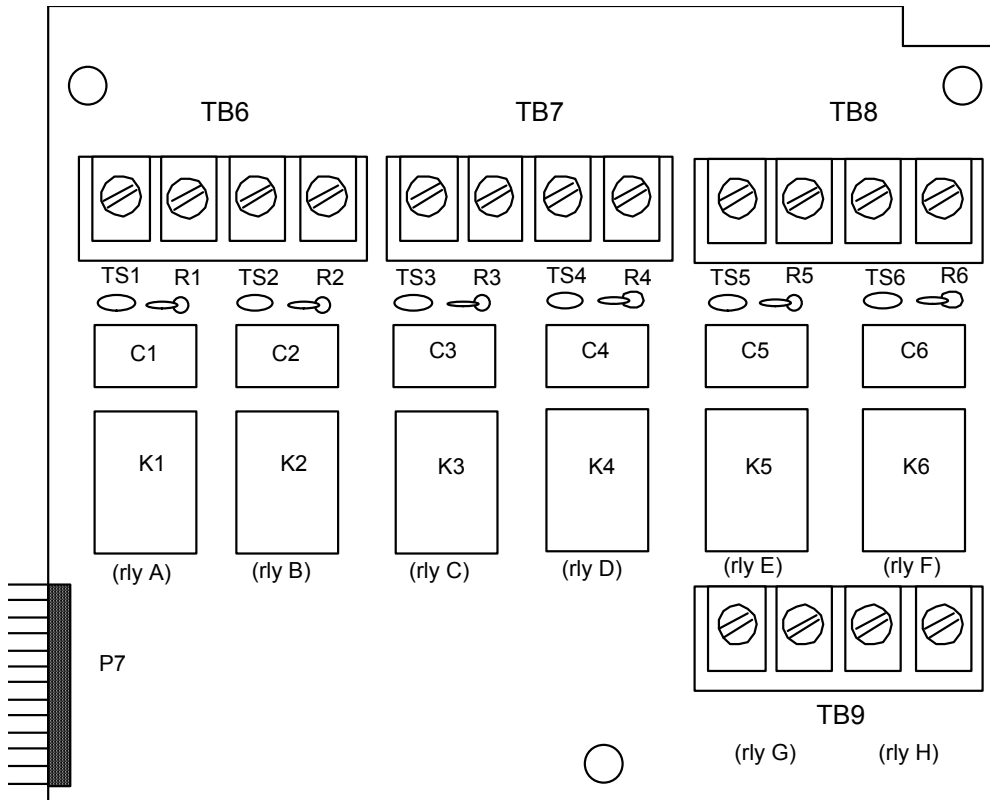

If the relay is connected to a high impedance AC device, the snubber network used to protect the relay contact may cause the output to appear to be activated when the relay is off. To cure the problem, cut the snubber resistor for the output that is being affected.

<u>Resistor</u>	<u>Relay</u>
R1	Relay A
R2	Relay B
R3	Relay C
R4	Relay D
R5	Relay E
R6	Relay F

**FIGURE A-3 - SPDT RELAY/SSR DRIVER OUTPUT BOARD**

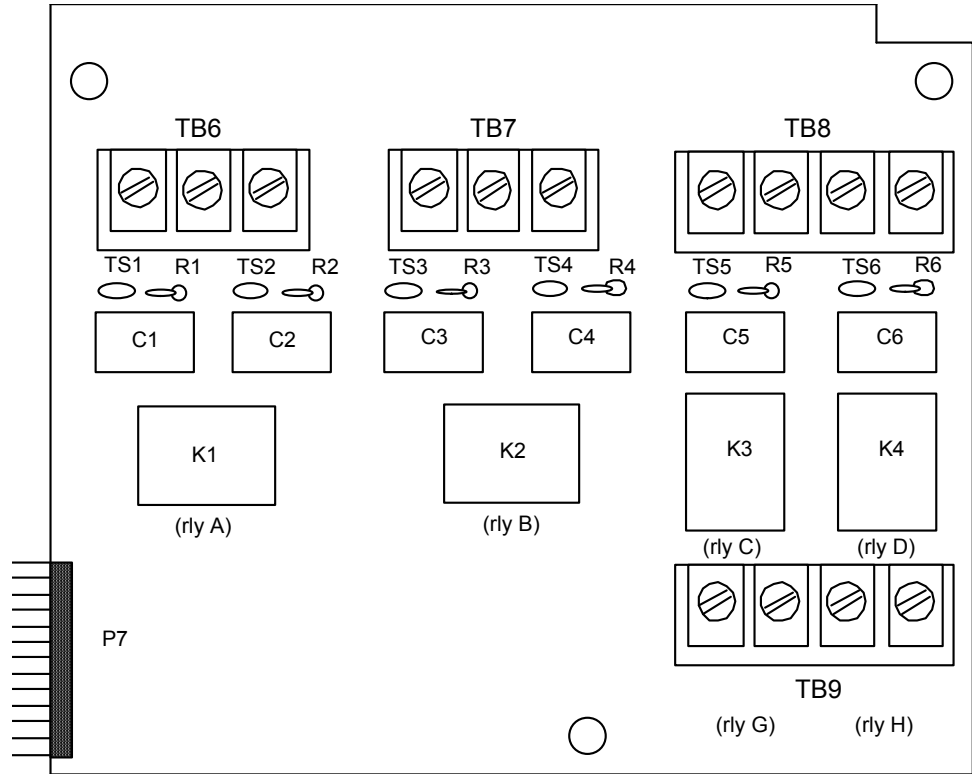

If the relay is connected to a high impedance AC device, the snubber network used to protect the relay contact may cause the output to appear to be activated when the relay is off. To cure the problem, cut the snubber resistor for the output that is being affected.

Resistor

R1, R2  
R3, R4  
R5  
R6

Relay

Relay A  
Relay B  
Relay C  
Relay D

**FIGURE A-4 - CURRENT OUTPUT BOARD**

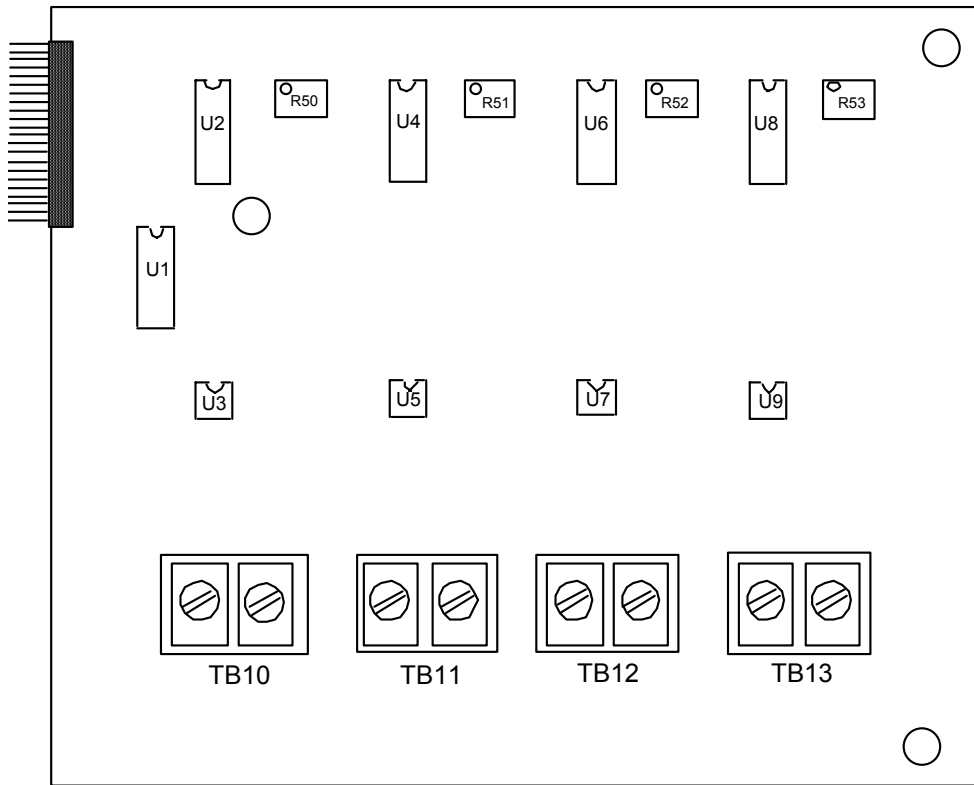

If this option board was ordered, you will find it located in the lower right hand corner of the instrument.

---

## Appendix B

### Glossary

#### DISPLAY FILTER FACTOR

This parameter is adjustable from 1 to 20 which represents the number of scans per second of the process variable that are averaged together before updating the displayed and recorded value. The factory default value is 1 = no filtering. Display code **dFF**.

#### HYSTERESIS

This parameter is adjustable from 0 to 300 units representing the width of the band (half above and half below setpoint). Used with Alarm outputs to reduce cycling. For instance, with a value of 4 and an alarm point of 70 the output will turn ON when the process variable drops to 68 and stay ON until 72 is reached, then turn OFF the output. Does not apply to Limits. Factory default = 3. Display code **HyAo**.

#### INPUT CORRECTION

This parameter is adjustable from -300 to 300 units and is used as a method to compensate for a linear sensor error. Factory default is 0 = no correction. Display code **iCor**.

#### PEN ACTION ON POWER UP

This parameter specifies whether this pen, on a power-up, will drive to the "Home " position (center of chart), then return to its correct position. This is done as a Cal Check. Settings are 0=go to "home" and 1=remain in last position prior to power down. Default=0.

#### PLATEN

The flat surface in the instrument upon which the chart rotates.

#### PROCESS FILTER FACTOR

This parameter is adjustable from 1 to 20 which represents the number of scans per second of the process variable that are averaged together before updating the process value used for alarm and PV output purposes. The factory default value is 1 = no filtering. Display code **PFF**.

#### PROCESS OUTPUT

Allows re-transmission of the process variable. Factory default is 0 = not selected. Display code **Pout**. If selected, must be assigned to a current output and scaled using Process Output upper and lower values.

#### PROCESS OUTPUT UPPER AND LOWER VALUES

(Used in conjunction with process output)

These parameters specify the process value range over which the assigned current output will decrease linearly from 100% to 0%. If the process value is greater than **Pou** the output will be 100%/ If the process value is less than **PoL** the output will be 0%. Factory default values are 2000 for the upper value and 0 for the lower value. Display codes **Pou** (upper) and **PoL** (lower).

#### PROCESS ROUNDING

This parameter is adjustable from 0 to 100 units and is used to round the process value to the nearest value specified. This is for display only and does not affect the recorded value or control action. Intended for use where the engineering units span is large, to reduce display fluctuation. Factory default is 0 = no rounding. Display code **Prnd**. (e.g. **Prnd** = 3, Process Value = -6, -3, 0, 3, 6, 9....).

# Appendix C - Order Matrix

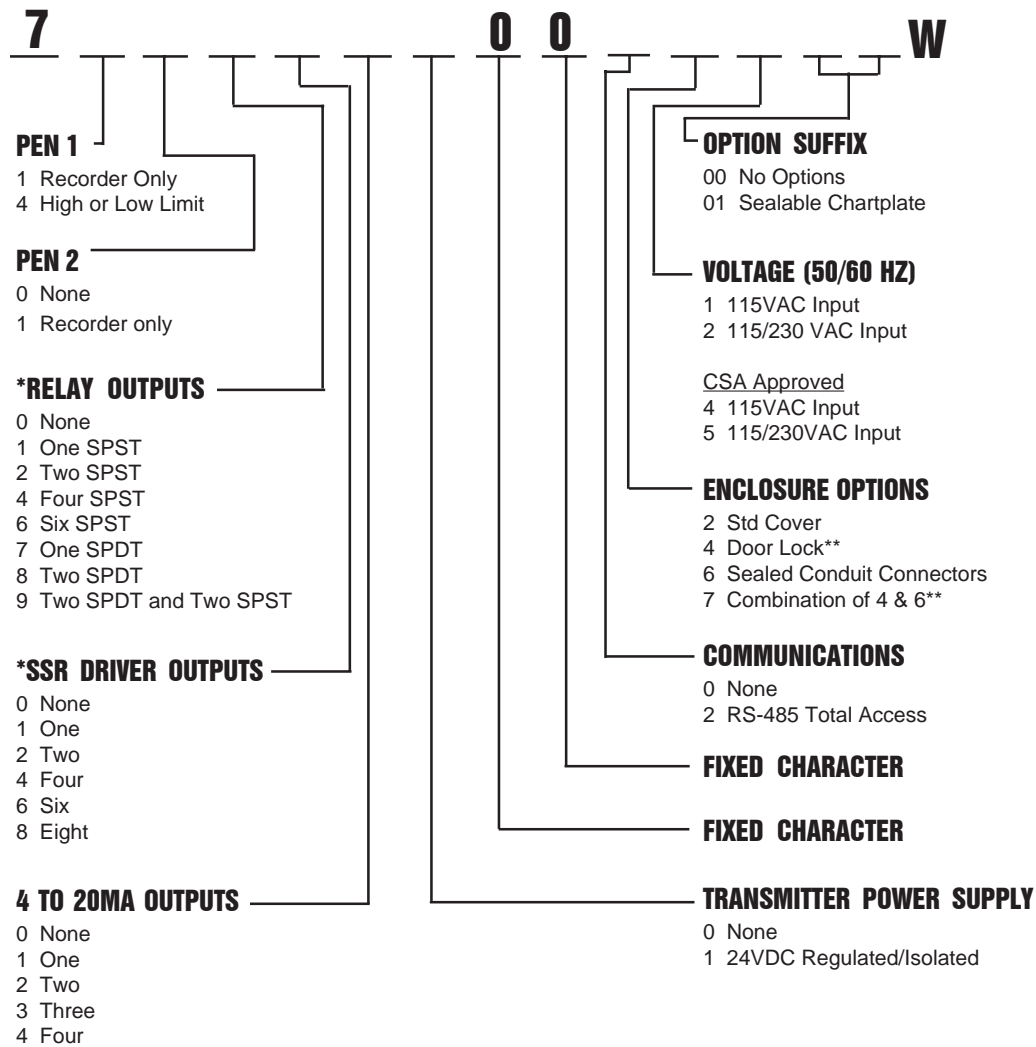

These recorders incorporate a NEMA 4 type enclosure.

\* Total quantity of SPST Relays and SSR Drivers must be less than or equal to (8) eight. When SPDT relays are included, the total must be less than or equal to six.

\*\* This option comes with a structural foam cover.

NOTE: 4-20mA Inputs are accommodated using the 1-5V Input and a 250 ohm Shunt Resistor (provided with unit) or the 10-50mA Input and a 2.5 ohm Shunt resistor.

---

## Appendix D - Specifications

Measurement Error Limit	<ul style="list-style-type: none"><li>• Type J, K, T, E, N, C T/C's and RTD +/- 0.25% of reading plus 1 degree @ 25 degrees C</li><li>• Type R, S, B T/C's +/- 0.25% of span @ 25 degrees C</li><li>• mA, mV, and VDC +/- 0.25% of scaled span plus 1 Whole Digit @ 25 degrees C</li></ul>
Ambient Temperature Error	0.01% of span per degree C deviation from 25 derees C
Scan Rate	1 scan/second
Display Decimal Positions	One, two or three decimal places (0.1 or 1 degree for T/C or RTD)
Noise Rejection	Normal mode, 85dB minimum at 60Hz or greater. Common mode, 90dB minimum, 115VAC maximum.
Line Voltage	115/230VAC +/- 1-% 50/60 Hz
Power Consumption	25VA maximum
Operating Temperature	32 degrees to 131 degrees F 0 degrees to 55 degrees C (ambient)
Storage Temperature	-40 degrees to 149 degrees F -40 degrees to 65 degrees C
Humidity	0 to 90% RH, noncondensing
Dimensions	13.19 H x 15.13 W x 3.63 Deep
Weight	20 pounds maximum
Sensor Fault Detection	Displays SnSr for sensor or transmitter break. Alarms go off. Relays are de-energized. <b>Fault detection is not functional for 0-5V or 0-20 mA inputs.</b>
Agency Approvals	UL Spec. 1092 File#E67237 CSA Spec. C22-2 File#LR39885
Transmitter Power Supply	Provides up to 40mA of current at 24 VDC
Warranty	3 years, see back page for details



---

## Input Specifications

### THERMOCOUPLE

TYPE	RANGE	TYPE	RANGE
J	0 to 760 C 0 to 1400 F	E	0 to 750 C 0 to 1400 F
K	0 to 1360 C 0 to 2500 F	B	200 to 1800 C 400 to 3300 F
T	-220 to 400 C -330 to 750 F	N	0 to 1300 C 0 to 2370 F
R	200 to 1650 C 400 to 3000 F	C	200 to 2300 C 390 to 4170 F
S	200 to 1650 C 400 to 3000 F		

---

### MILLIAMPS

4-20mADC  
(with resistor)

### VOLTS

0 to 5VDC  
1 to 5 VDC

### RTD

100 OHM  
(.00385 OHMS/OHM/C)  
-140 to 400 C

### MILLIVOLTS

-220 to 750 F  
0 to 25 mV  
0 to 50mV  
10 to 50mV  
(can be scaled to any portion of this range)

---

### ALARM ADJUSTMENTS

Process Alarm	-9999 to 9999 units
Hysteresis	0 to 300 units

---

### ALARM OUTPUT

Relay	SPST 115VAC: 5.0A Resistive, 1/8HP or 250VA 230VAC: 2.5A Resistive, 1/8HP or 250VA
SSR Driver	Open collector output Short circuit protected @ 100mA maximum. Provides 4VDC at 20mA or 3 VDC at 40mA.

---

### PROCESS OUTPUT

4-20 or 0 -20 mADC into 650 ohms maximum load.

---

### DISPLAY

Digital Display	Two possible; one per installed pen. Red LED's 0.56 " high.
Status Indicators	LED indicators for Alarm 1 and Alarm 2, and process value units, as applicable for each model (°F, °C, and U).

---

## **RECORD**

Chart	10 inch circular chart; 100 charts furnished with each instrument if standard range
Chart Range	-9999 to 9999 degrees/units
Chart Drive	DC stepper motor
Chart Rotation	User configurable from 0.1 to 999.9 hours per revolution
Pen Type	Disposable Fiber-tip
Pen Color	Pen 1 - Red Pen 2 - Green
Pen Response Time	< 9 seconds over chart span
Accuracy	± 1.0% of chart span max., error from displayed value.
Chart Rotation Accuracy	± .5% of chart rotation time

---

## **DIGITAL COMMUNICATIONS**

Type	RS-485 serial communications port. Half-duplex bi-directional communications scheme.
Character Format	ASCII
Protocol	Per ANSI X3.28 subcategories 2.5 & A4
Configuration	User configurable to Monitor (read only) or Normal (read and write)
Bit Rate	User configurable to 300, 600, 1200, 2400, 4800, or 9600 bits per second
Address	User configurable for each pen; 0 to 99

# Appendix E

## Software Reference Sheet

ENABLE	MODE
EtSt	
ECAL	
EPro	
EASt	
ESPC	

	ALARM SET	
	Pen 1	Pen 2
PAL1		
PAL2		

	PROGRAM		MODE
	Pen 1	Pen 2	
inPS			rLyA
iCor			rLyb
AL1			rLyC
AL2			rLyd
disP			rLyE
dPoS			rLyF
Euu			rLyg
EuL			rLyH
HyAo			CurA
SPuL			Curb
SPLL			CurC
Prnd			Curd
dFF			CoAr
PFF			Cobr
Pout			CoCr
Pou			Codr
PoL			Crt
Cru			PAPu
CrL			Coo
PAEC			CCon
			CbS
			CAd1
			CAd2

---

## ***Warranty and Return Statement***

These products are sold by The Anderson Instrument Company (Anderson) under the warranties set forth in the following paragraphs. Such warranties are extended only with respect to a purchase of these products, as new merchandise, directly from Anderson or from an Anderson distributor, representative or reseller, and are extended only to the first buyer thereof who purchases them other than for the purpose of resale.

### ***Warranty***

These products are warranted to be free from functional defects in materials and workmanship at the time the products leave the Anderson factory and to conform at that time to the specifications set forth in the relevant Anderson instruction manual or manuals, sheet or sheets, for such products for a period of three years.

**THERE ARE NO EXPRESSED OR IMPLIED WARRANTIES WHICH EXTEND BEYOND THE WARRANTIES HEREIN AND ABOVE SET FORTH. ANDERSON MAKES NO WARRANTY OF MERCHANTABILITY OR FITNESS FOR A PARTICULAR PURPOSE WITH RESPECT TO THE PRODUCTS.**

### ***Limitations***

Anderson shall not be liable for any incidental damages, consequential damages, special damages, or any other damages, costs or expenses excepting only the cost or expense of repair or replacement as described above.

Products must be installed and maintained in accordance with Anderson instructions. Users are responsible for the suitability of the products to their application. There is no warranty against damage resulting from corrosion, misapplication, improper specifications or other operating condition beyond our control. Claims against carriers for damage in transit must be filed by the buyer.

This warranty is void if the purchaser uses non-factory approved replacement parts and supplies or if the purchaser attempts to repair the product themselves or through a third party without Anderson authorization.

### ***Returns***

Anderson's sole and exclusive obligation and buyer's sole and exclusive remedy under the above warranty is limited to repairing or replacing (at Anderson's option), free of charge, the products which are reported in writing to Anderson at its main office indicated below.

Anderson is to be advised of return requests during normal business hours and such returns are to include a statement of the observed deficiency. The buyer shall pre-pay shipping charges for products returned and Anderson or its representative shall pay for the return of the products to the buyer.

Approved returns should be sent to:           ANDERSON INSTRUMENT COMPANY INC.  
  156 AURIESVILLE ROAD  
  FULTONVILLE, NY 12072 USA  
  
  ATT: REPAIR DEPARTMENT